

- **Unique Four Electrode Conductivity Sensors for Wide Variety of Applications**
- **Versatile Installation Options (Threaded, Quick Change, Retractable)**
- **Specialized High Pressure / High Temperature Options**
- **Sensors are Compatible with Most Major Manufacturer's Analyzers**
- **CRN Registration for Canada**



Conductivity sensors measure the specific conductance of liquid processes. The specific conductance is directly related to the presence of ionic species and their concentration. Barben Analytical offers a full range of four electrode contacting conductivity sensors for a variety of industrial measurement applications.

Four Electrode Conductivity Sensors

- Ideal for medium to high conductivity applications such as condensate return monitoring
- A low volume, affordable alternative to toroidal sensor technology
- Additional electrode pair compensates for particulate and scale build-up.
- Threaded in-line, submersible, and "Hot Tap" retractable product options
- Sensor diagnostics (analyzer dependent)

Compatibility with All Major Vendor's Electronics

- Proven with major vendors of conductivity analyzers (Rosemount, ABB, Knick)
- Improve your measurement by replacing only the sensor
- Wiring information available

Industrial Mounting Options

- Mounting fittings for sample line installations
- Ball Valve "Hot Tap" retraction solutions
- Variety of materials for corrosive applications

Liquid Conductivity

Four Electrode with CRN Registration

Well known for industrial pH sensor technology; Barben Analytical also provides a full range of CRN registered four electrode industrial conductivity sensors to support your applications.

Four Electrode Sensor Technology

As the name suggests, four electrode sensors add an additional pair of electrodes to the conventional two electrode sensor design. This additional pair of electrodes provides sensor diagnostics which can then be used to compensate the measurement if scale or particulate build-up occur on electrodes.

Four electrode conductivity sensors can withstand coating and scale which might otherwise foul a traditional two electrode sensor. Typical applications include the following:

- Leak Detection
- Condensate Return
- Pulp Stock Washer Vats
- Salinity
- Chemical Concentration
- Clean-In-Place

Four Electrode Sensor Technology (How it works)

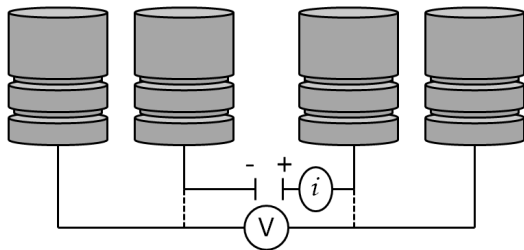

Figure 1

Four electrode sensor designs keep a constant current through two of the electrodes and let the drive voltage change. If fouling occurs then the drive voltage can be increased to compensate the measurement.

Pros

- Compensation for coating and build-up
- Wide measurement range
- Sensor diagnostics if fouling is too great (analyzer dependent)
- No polarization affect

Cons

- Not as accurate as two electrode sensors at low conductivity
- Susceptible to corrosion
- Limited availability of analyzers (ABB, Rosemount, Mettler Toledo, Knick)
- Conductive field can be distorted by pipe walls and flow cells

Sensor Selection: Mounting

Mounting should be considered as part of sensor selection. Examples of various process mounting configurations are provided below.

In-line Sensor Mounting: In-line installations are common on sample streams from the main process. The sensor may be mounted in a piping tee or a flow cell. The electrodes should be fully exposed to the process flow. Four Electrode Sensors require at least 1 inch of clearance from pipe walls to avoid any distortion of reading. Isolation valves should be upstream / downstream of sensor for removal. (fig. 2)

Hot Tap Sensor Mounting: Hot Tap refers to the ability to remove the sensor from the process while under pressure. A ball valve is used to isolate the sensor for removal. (fig. 3)

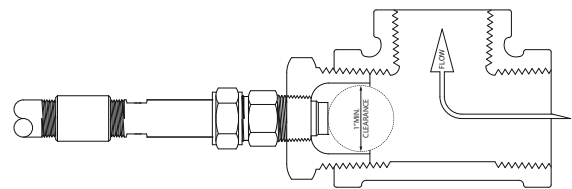

In-line Mounting Example - 551 Four Electrode Sensor
(note space in front of sensor to avoid measurement error)

Figure 2

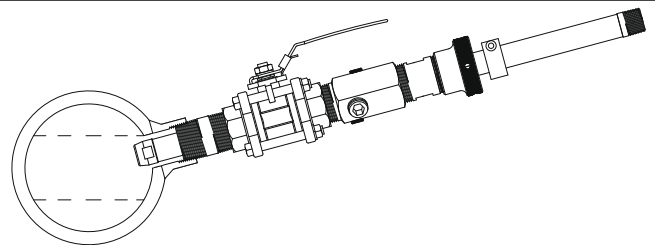

Hot Tap Mounting Example - 547 Four Electrode, Isolation Ball Valve
& Hand Tight Compression fitting

Figure 3

Liquid Conductivity Four Electrode with CRN Registration

Submersible Mounting: This mounting style is used when the sensor is installed in a tank, or open channel. The 3/4" NPT threads on the rear of the sensor are used to mount the sensor on the end of a customer supplied "dip tube". The dip tube allows the sensor to be submerged in the application. This type of installation is best suited for either the 546 or 551 sensor. (fig. 4)

Sensor Selection: Electrodes

All Barben four electrode conductivity sensors have either low range or high range electrodes. Low range electrodes have one pair slightly longer to provide more surface area in low conductivity solutions. (figs. 5 & 6)

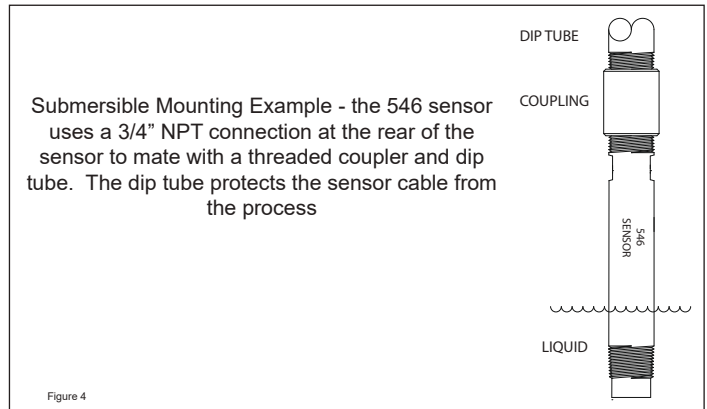

Four Electrode Tip Options

HIGH RANGE ELECTRODES
(0 - 2 SIEMENS)
SH, TH, HH SERIES

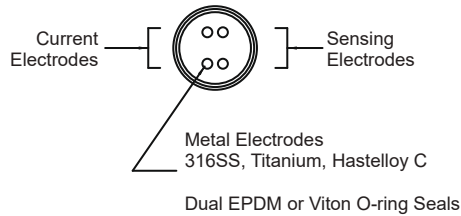

Flush High Range Electrodes

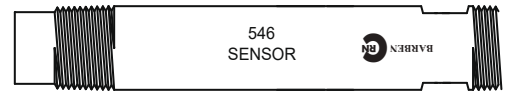

LOW RANGE ELECTRODES
(0 - 1400 MICROSIEMENS)
SM, HM SERIES

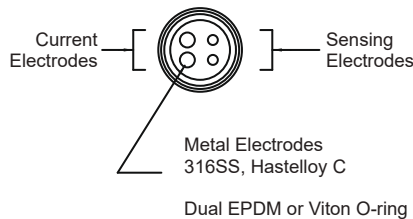

Extended Low Range Current Electrodes

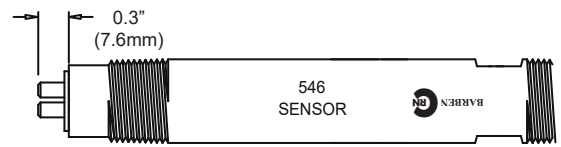

Figure 5

Typical Measurement Ranges for Four Electrode Sensors

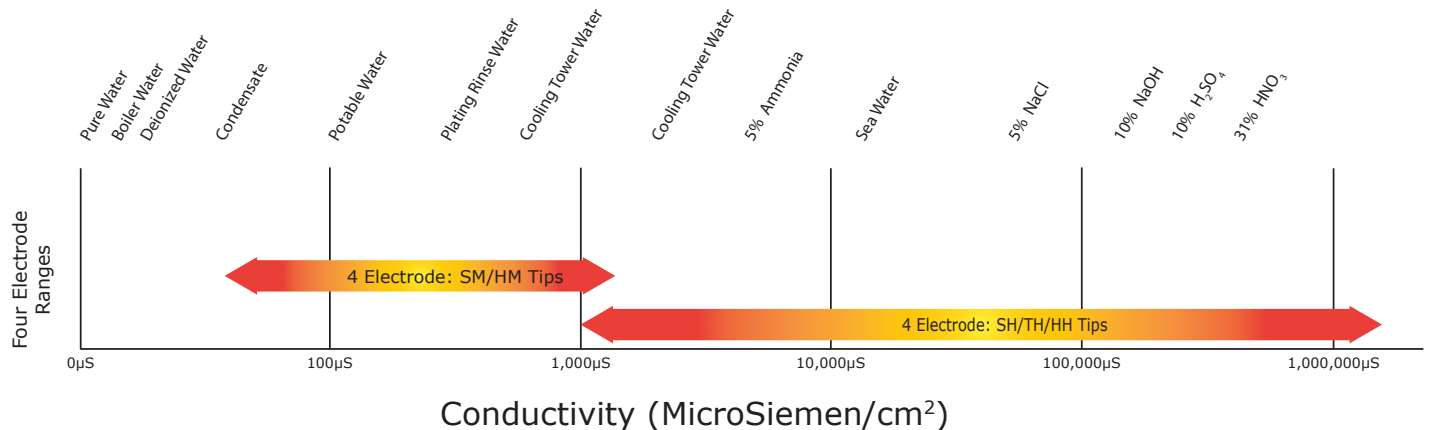

Figure 6

Liquid Conductivity Four Electrode with CRN Registration

Model 546

Threaded In-line, Submersible, High Pressure Hot Tap

The versatile Model 546 is suitable for in-line sample stream applications using the 3/4 inch NPT process connection. A similar connection on the rear of the sensor is used to mount the sensor in submersible and high pressure hot tap installations. With tip lengths from 0.5 to 3.5 inches the 546 sensor can fit through extended pipe nipples and flanges to reach into the process and provide optimum conductivity measurement.

CRN Registration (Alberta)
0F16420.2



Maximum Allowable Working Pressure / Temperature*

In-line: 150 PSIG @ -4 to 266°F (-20 to 130°C)

Hot Tap: 300 PSIG @ -4 to 131°F (-20 to 55°C)

290 PSIG @ 131 to 194°F (55 to 90°C)

230 PSIG @ 194 to 266°F (90 to 130°C)

* MAWP based on min design temperature to max temperature listed.

Minimum Design Temperature

-4°F (-20°C)

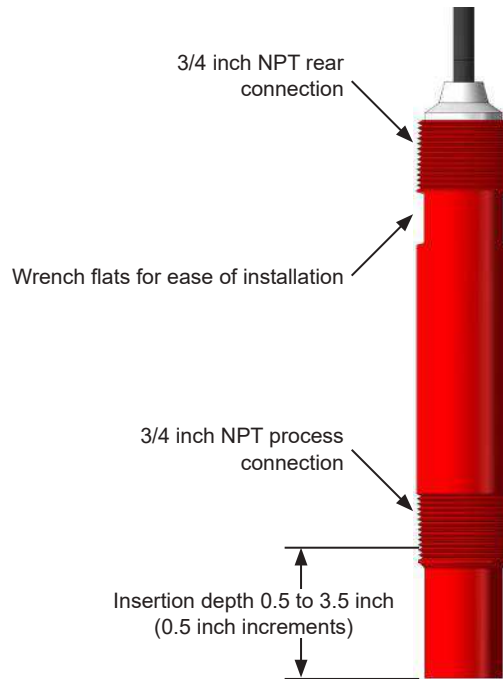

546 In-line Installation

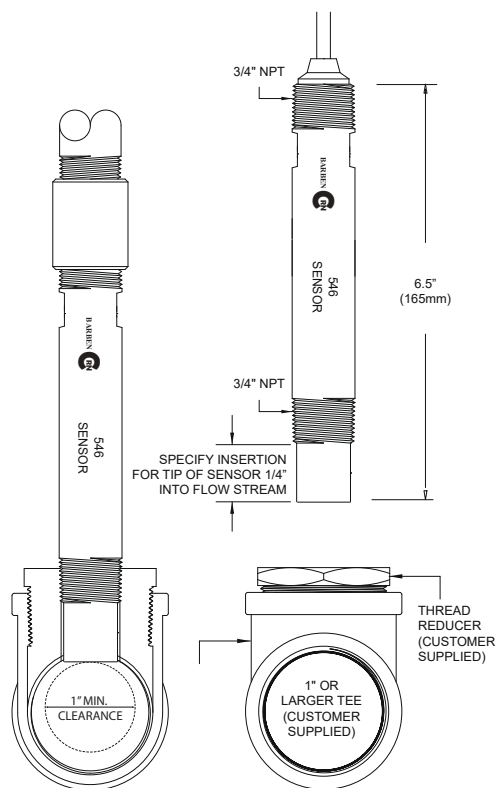

Figure 7

546 High Pressure Hot Tap Installation

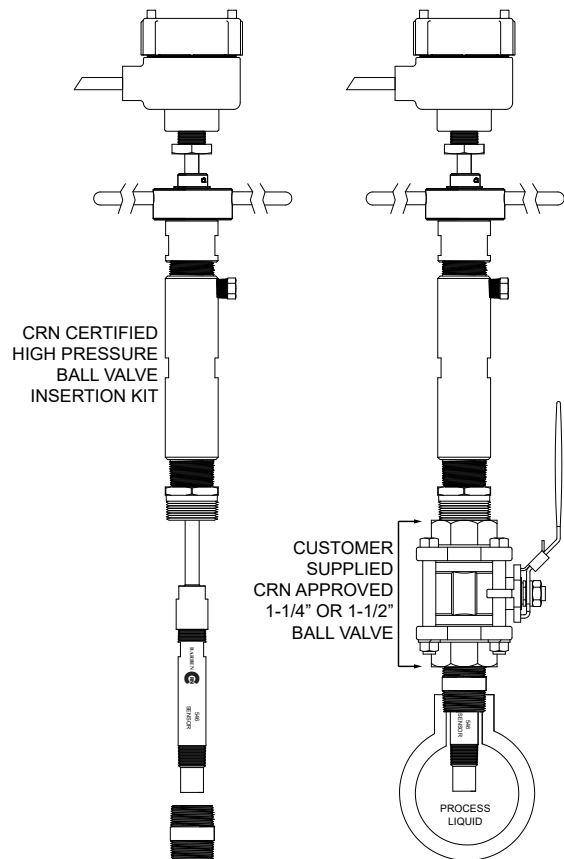

Figure 8

Liquid Conductivity Four Electrode with CRN Registration

Model 551 Quick Change In-line

In some in-line applications sensor removal for routine cleaning or calibration becomes difficult due to conduit or cabling. The 551 Quick Change Sensor offers a unique method to extract the sensor through a "Nut Lock" Adapter system. The Nut Lock Adapter threads directly into 1 inch NPT process connections. The 551 sensor also includes a 3/4 inch rear connection for use in submersible applications.

CRN Registration (Alberta)
0F16420.2



Maximum Allowable Working Pressure / Temperature*

286 PSIG @ -4°F (-20°C) to 131°F (55°C)
264 PSIG @ 131°F (55°C) to 194°F (90°C)
239 PSIG @ 194°F (90°C) to 266°F (130°C)

* MAWP based on min design temperature to max temperature listed.

Minimum Design Temperature

-4°F (-20°C)

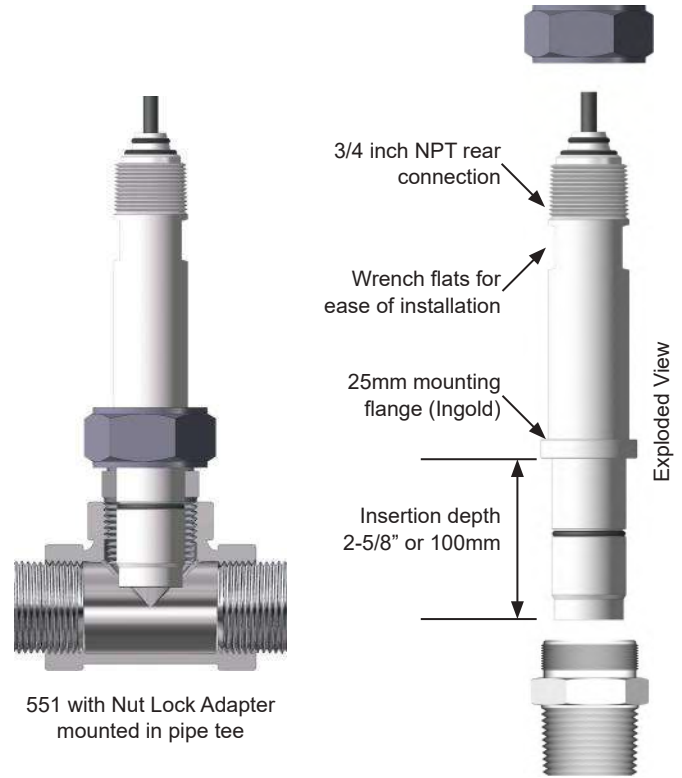

551 In-line Installation

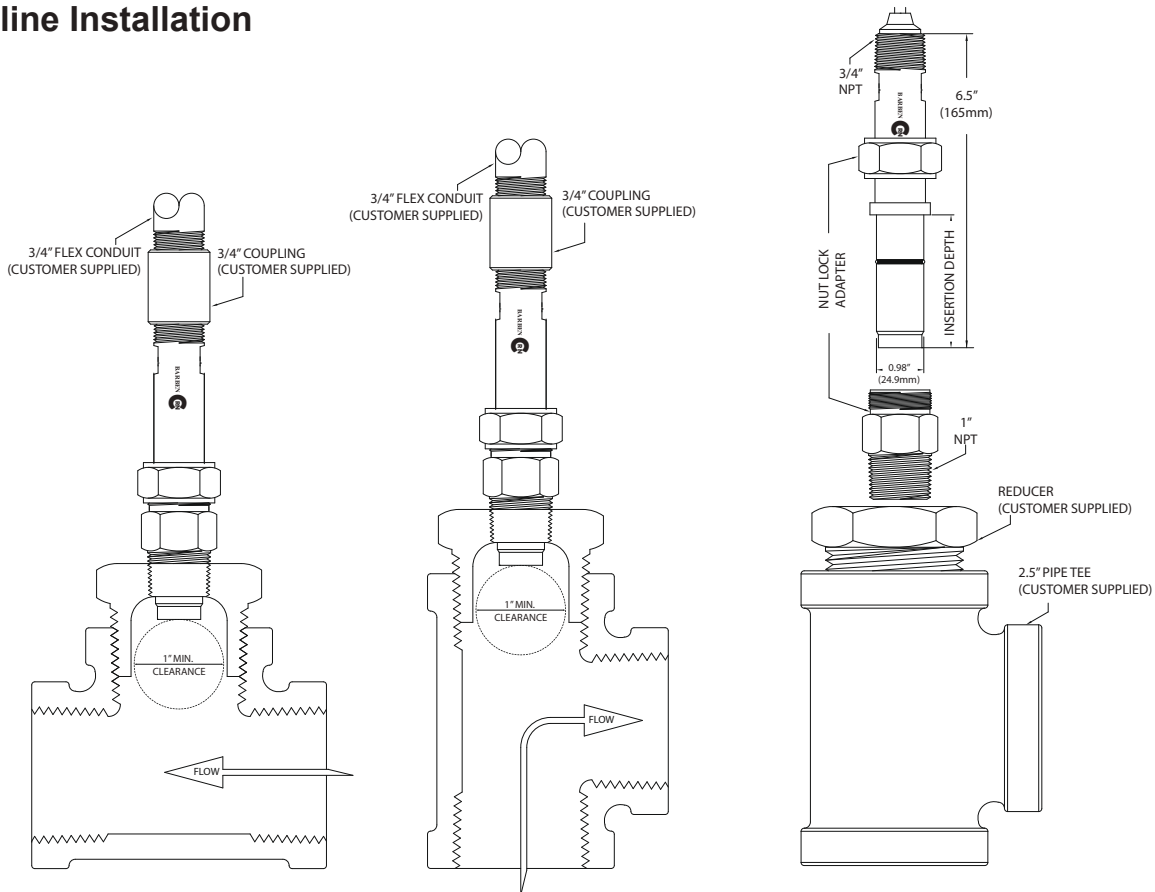

Liquid Conductivity Four Electrode with CRN Registration

Model 547 Hot Tap Retractable

The Model 547 is a replaceable, cartridge style conductivity sensor. The sensor is fitted into a metallic sheath which is installed into an isolation valve assembly. This design is ideal for applications where measurement on a sample line is not desirable. When the sensor is removed for cleaning or calibration the valve can be used for isolation from the process. All metallic hardware is fully reusable thus saving money with on-going replacement expense.

CRN Registration (Alberta)
0F16420.2



Maximum Allowable Working Pressure / Temperature*
Operating: 150 PSIG @ -4 to 266°F (-20 to 130°C)
Service: 65 PSIG recommended for retraction/insertion

* MAWP based on min design temperature to max temperature listed.

Minimum Design Temperature
-4°F (-20°C)

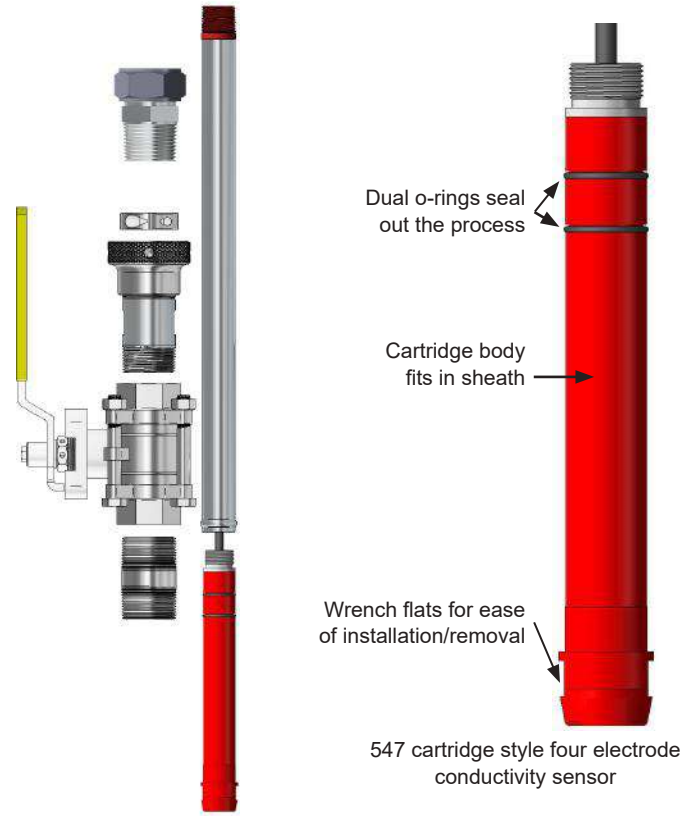

Exploded view with ball valve assembly (customer supplied) and compression fitting

547 cartridge style four electrode conductivity sensor

547 Hot Tap Installation

Figure 10

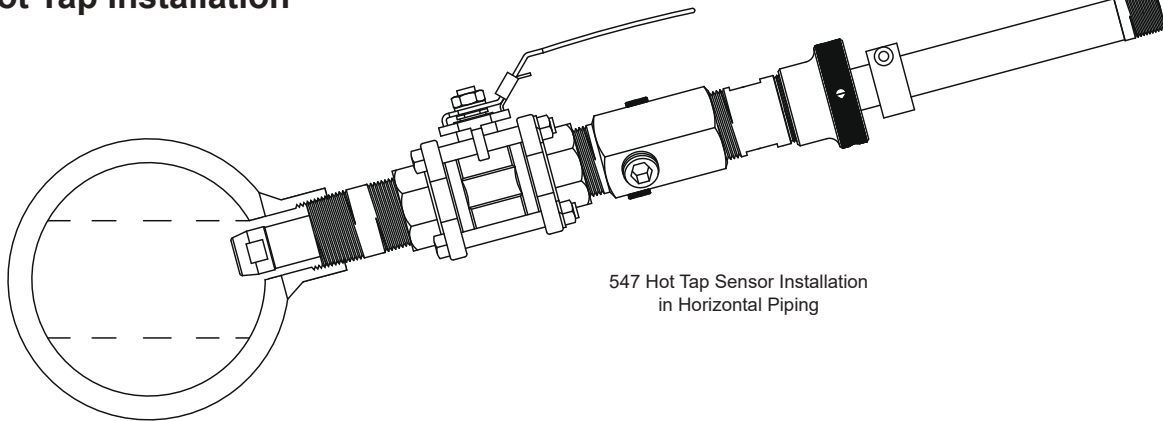

547 Hot Tap Sensor Installation in Horizontal Piping

547 In-line Sizing Example

$$\text{Insertion Depth} = (A) - (B) - (C)$$

The insertion depth should exceed any mounting hardware (flange, standoff or thread-o-let) plus the pipe wall thickness by at least 1/4" (6mm) to get the tip of the sensor into the process.

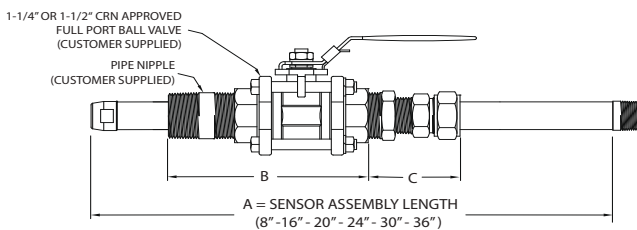

Valve & Nipple (Customer Supplied)	"B" Estimate	Compression Fitting	"C" Estimate
1-1/4" SS Valve	6.5"	Wrench Tight	3.0"
		Hand Tight	3.5"
1-1/2" SS Valve	7.1"	Wrench Tight	3.0"
		Hand Tight	4.5"
1-1/4" Kynar Valve	8.0"	Wrench Tight	3.0"
		Hand Tight	3.5"
1-1/2" Kynar Valve	8.6"	Wrench Tight	3.0"
		Hand Tight	4.5"

Liquid Conductivity Four Electrode with CRN Registration

551 / 546 / 547 Four Electrode Conductivity Sensors

Label	Seals	Body Style	Electrodes	TC	Insertion Depth	Cable	Terminations	
A	Alberta CRN Marked Product (Kynar body PEEK insulator)							
	Seals							
	E	EPDM						
	V	Viton						
	Configuration							
	551	Quick-Change Inline / Submersible Sensor						
	546	Threaded 3/4" NPT, In-line / Submersible / High Pressure Retractable Sensor						
	547	Cartridge Sensor for Valve Insertion						
	Electrode Range and Material (Actual range is subject to analyzer limits)							
	SM	0 - 1,400 MicroSiemen - 316 Stainless						
	HM	0 - 1,400 MicroSiemen - Hastelloy C-276						
	SH	0 - 2 Siemens - 316 Stainless						
	TH	0 - 2 Siemens - Titanium Grade 2						
	HH	0 - 2 Siemens - Hastelloy C-276						
	Integral Temperature Compensation							
	K	PT1000						
	C	PT100						
	B	3K Ohm Balco (120°C Max)						
	(Blank)	Other						
	Insertion Depth							
	S	Standard for 547 and 551 (2-5/8")						
	0.5	1/2" (546 Only, Recommended for High Pressure Hot Tap)						
	1.0	1" (546 Only)						
	1.5	1-1/2" (546 Only)						
	2.0	2" (546 Only)						
	2.5	2-1/2" (546 Only)						
	3.0	3" (546 Only)						
	3.5	3-1/2" (546 Only)						
	100	100mm (551 Only)						
	Cable							
	T	8" Pigtail for (Junction Box 546/551)						
	T1	8" Pigtail for (8" assy 547)						
	T2	8" Pigtail for (16" 547 assy)						
	T3	8" Pigtail for (20" 547 assy or 546 Hot Tap)						
	T4	8" Pigtail for (24" 547 assy)						
	T5	8" Pigtail for (30" 547 assy)						
	T6	8" Pigtail for (36" 547 assy)						
	1 to 100	1 - 100 foot cable						
	Lead Terminations							
	T	All Tinned						
	S	All Spades #6						
Label	Seals	Body Style	Electrodes	TC	Insertion Depth	Cable	Terminations	
A	E	547	SM	C	S	5	T	Typical Sensor Configuration

Liquid Conductivity Four Electrode with CRN Registration

546 High Pressure Hot Tap Accessories

Part Number (use with 1-1/4" valves)	Part Number (use with 1-1/2" valves)	Accessory Description
AB5104K-S125V	AB5104K-S150V	316 Stainless Steel High Pressure Hot Tap Kit with Viton Seals
AB5104K-S125E	AB5104K-S150E	316 Stainless Steel High Pressure Hot Tap Kit with EPDM Seals
AB5104K-S125K	AB5104K-S150K	316 Stainless Steel High Pressure Hot Tap Kit with FFKM (Kalrez) Seals
AB5104K-T125V	AB5104K-T150V	Titanium Grade 2 High Pressure Hot Tap Kit with Viton Seals
AB5104K-T125E	AB5104K-T150E	Titanium Grade 2 High Pressure Hot Tap Kit with EPDM Seals
AB5104K-T125K	AB5104K-T150K	Titanium Grade 2 High Pressure Hot Tap Kit with FFKM (Kalrez) Seals

551 Nut Lock Adapter Accessories

Part Number	Accessory Description	Specification
AB4954-0022	Nut Lock Adapter, 316 Stainless Steel, 1" MNPT Mounting Thread	ASTM A276 316 (Body), ASTM A479 316 (Nut)
AB4954-0036	Nut Lock Adapter, Titanium Grade 2 (wetted), 1" MNPT Mounting Thread	UNS N10276 (Body), ASTM A479 316 (Nut)
AB4954-0040	Nut Lock Adapter, Hastelloy C-276 (wetted), 1" MNPT Mounting Thread	ASTM B348 (Body), ASTM A479 316 (Nut)

547 Hot Tap Accessories

CRN Sheath Kits for 547 Cartridge Style Sensors			
316SS Part #	Titanium Part #	Hastelloy C-276 Part #	Accessory Description
AB5104-0068V	AB5104-0058V	AB5104-0078V	8" Kit, Kynar Backpiece with Viton Seals (non-wetted)
AB5104-0216V	AB5104-0116V	AB5104-0316V	16" Kit, Kynar Backpiece with Viton Seals (non-wetted)
AB5104-0220V	AB5104-0120V	AB5104-0320V	20" Kit, Kynar Backpiece with Viton Seals (non-wetted)
AB5104-0224V	AB5104-0124V	AB5104-0324V	24" Kit, Kynar Backpiece with Viton Seals (non-wetted)
AB5104-0230V	AB5104-0130V	AB5104-0330V	30" Kit, Kynar Backpiece with Viton Seals (non-wetted)
AB5104-0236V	AB5104-0136V	AB5104-0336V	36" Kit, Kynar Backpiece with Viton Seals (non-wetted)

CRN Wrench Tight Compression Fittings for 547 Cartridge Style Sensors (Works with all sheath kits listed above)			
316SS Part #	Titanium Part #	Hastelloy C-276 Part #	Accessory Description
AB4954-0001V	AB4954-0009V	AB4954-0002V	Wrench Tight Compression Fitting with Viton Seal, 1" Male NPT
AB4954-0001E	AB4954-0009E	AB4954-0002E	Wrench Tight Compression Fitting with EPDM Seal, 1" Male NPT
AB4954-0001K	AB4954-0009K	AB4954-0002K	Wrench Tight Compression Fitting with FFKM (Kalrez) Seal, 1" Male NPT

CRN Hand Tight Compression Fittings for 547 Cartridge Style Sensors (Works with all sheath kits listed above)			
316SS Part #	Titanium Part #	Hastelloy C-276 Part #	Accessory Description
AB4954-0003V	AB4954-0005V	AB4954-0004V	Hand Tight Compression Fitting with Viton Seal, 1-1/4" Male NPT
AB4954-0003E	AB4954-0005E	AB4954-0004E	Hand Tight Compression Fitting with EPDM Seal, 1-1/4" Male NPT
AB4954-0003K	AB4954-0005K	AB4954-0004K	Hand Tight Compression Fitting with FFKM (Kalrez) Seal, 1-1/4" Male NPT

CRN Clean / Calibrate / Purge Fittings for 547 Cartridge Style Sensors (Install between customer supplied isolation valve and related CRN compression fitting)			
316SS Part #	Titanium Part #	Hastelloy C-276 Part #	Accessory Description
AB4954-0014	AB4954-0015		Clean / Calibrate / Purge Fitting with 3/8" ports, for Wrench Tight Compression fitting and 1-1/4" Female NPT isolation valve
AB4954-0023	AB4954-0024	AB4954-0018	Clean / Calibrate / Purge Fitting with 3/8" ports, for Wrench Tight Compression fitting and 1-1/2" Female NPT isolation valve
AB4954-0016	AB4954-0017	AB4954-0134	Clean / Calibrate / Purge Fitting with 3/8" ports, for Hand Tight Compression fitting and 1-1/4" Female NPT isolation valve
AB4954-0025	AB4954-0026	AB4954-0019	Clean / Calibrate / Purge Fitting with 3/8" ports, for Hand Tight Compression fitting and 1-1/2" Female NPT isolation valve

Contact Us

Barben Analytical is a leading supplier of analytical measurement technology targeting the industrial marketplace. It is a wholly owned subsidiary of Ametek.

Ametek has nearly 14,000 colleagues at over 120 manufacturing locations around the world. Supporting those operations are more than 80 sales and service locations across the United States and in more than 30 other countries around the world.

Barben Analytical
5200 Convair Drive
Carson City, NV 89706 USA

Toll Free: +1 (800) 993-9309
Phone: +1 (775) 883-2500
Fax: +1 (775) 297-4740
email: Sales.Barben@ametek.com
Web: www.BarbenAnalytical.com

Barben Analytical reserves the right to make technical changes or modify the contents of this document without prior notice. We reserve all rights in this document and in the subject matter and illustrations contained within.

Hastelloy® is a registered trademark of Haynes Intl Inc.
Kalrez® and Viton are registered trademarks of DuPont Dow Elastomers L.L.C.
Kynar® is a registered trademark of Elf Atochem North America Inc.
Teflon® is a registered trademark of E.I. DuPont de Nemours Company Inc.