

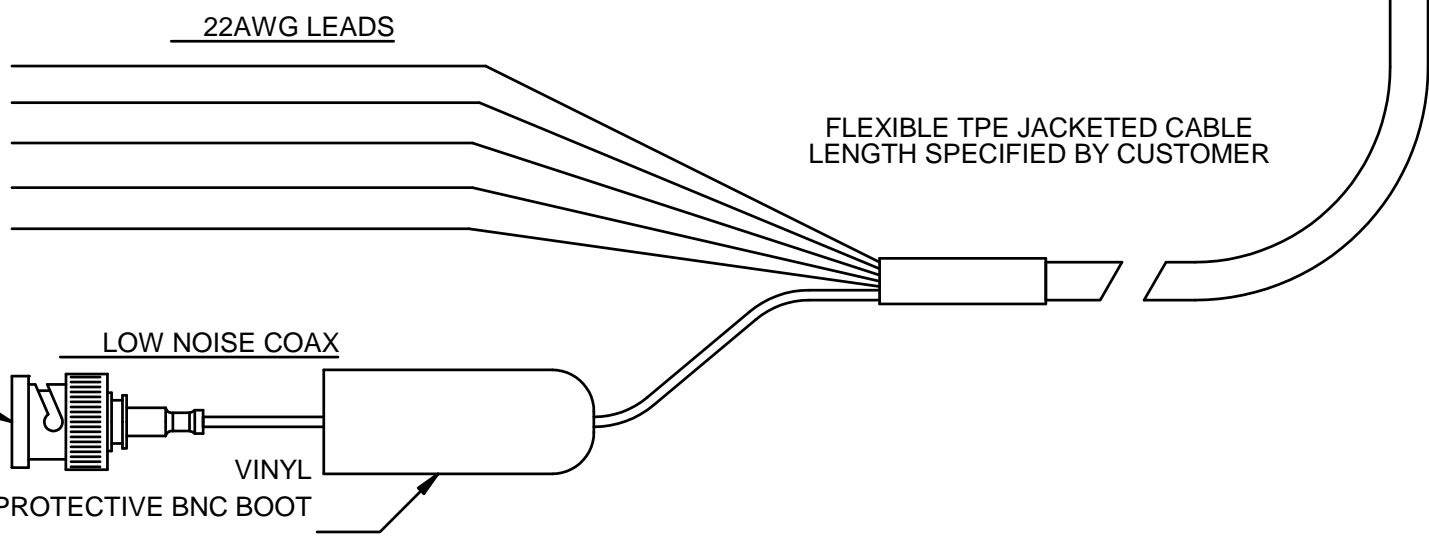

TEFLON LIQUID JUNCTION WITH THE FOLLOWING OPTIONS
 RUGGEDIZED HEMI, RUGGEDIZED FLAT, LOW TEMP HEMI ELECTRODES
 FLUSH, RECESSED (SUPPLIED DUAL NOTCHED AS SHOWN)
 EPDM, VITON OR KALREZ SEALS.

WIRING SHOWN ARE FOR EXAMPLE ONLY
 MANY WIRING CONFIGURATIONS ARE AVAILABLE
 SEE DRAWING P0033



MAXIMUM PRESSURE & TEMPERATURE RATINGS
 CPVC/POLYPRO MAX 100PSIG @75°C - 35PSIG@MAX 100°C
 KYNAR MAX 150PSIG @ 70°C -40PSIG @ MAX 130°C

REVISIONS				DIMENSIONS IN INCHES			MODEL 551 pH/ORP SENSOR OUTLINE	
REV	DATE	DESCRIPTION	DW N	APVD	TOLERANCES UNLESS OTHERWISE SPECIFIED			
A	02/02/01	PAGE 2, J-BOX DATA ADDED	HWM		DECIMALS	FRACTIONS	DRAWING NO.	2P0005
B	06/27/01	CPVC VERSION ADDED	HWM		.0000 +/- .0005	+/- .015	CHECKED	HWM
C	03/19/02	WIRING MOVED TO P0033	HWM		.000 +/- .005	ANGLES	APPROVED	HWM
D	07/19/11	UPDATE (ECO #937)	WC	HWM	.00 +/- .010	+/- 30MIN		
					.0 +/- .15		 5200 Convair Drive Carson City, NV 89706	
					DRAWING BY: HWM		PH(775)883-2500 FAX(775)297-4740	
					SCALE	DATE	SIZE	1 OF 2
					NON E	07/31/00	A	

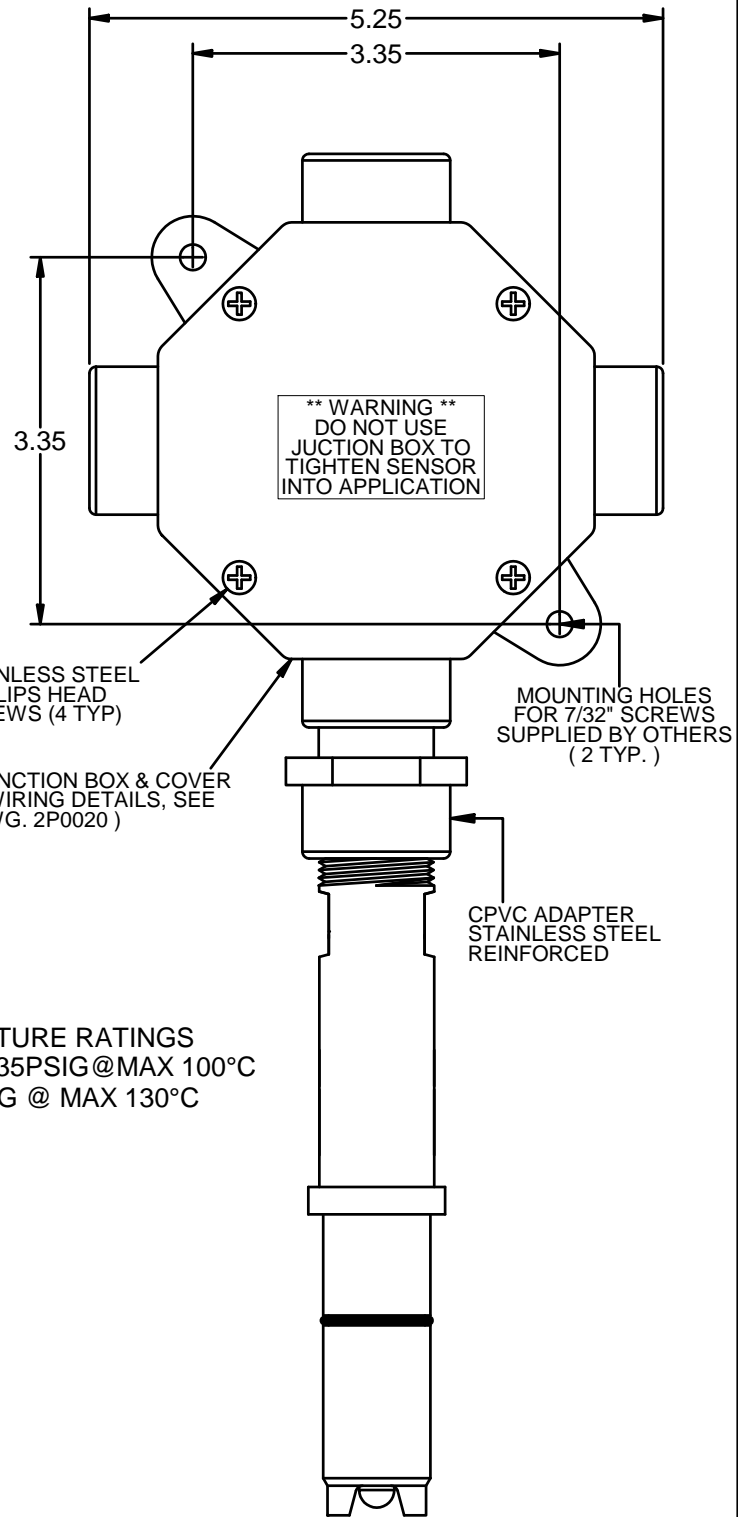
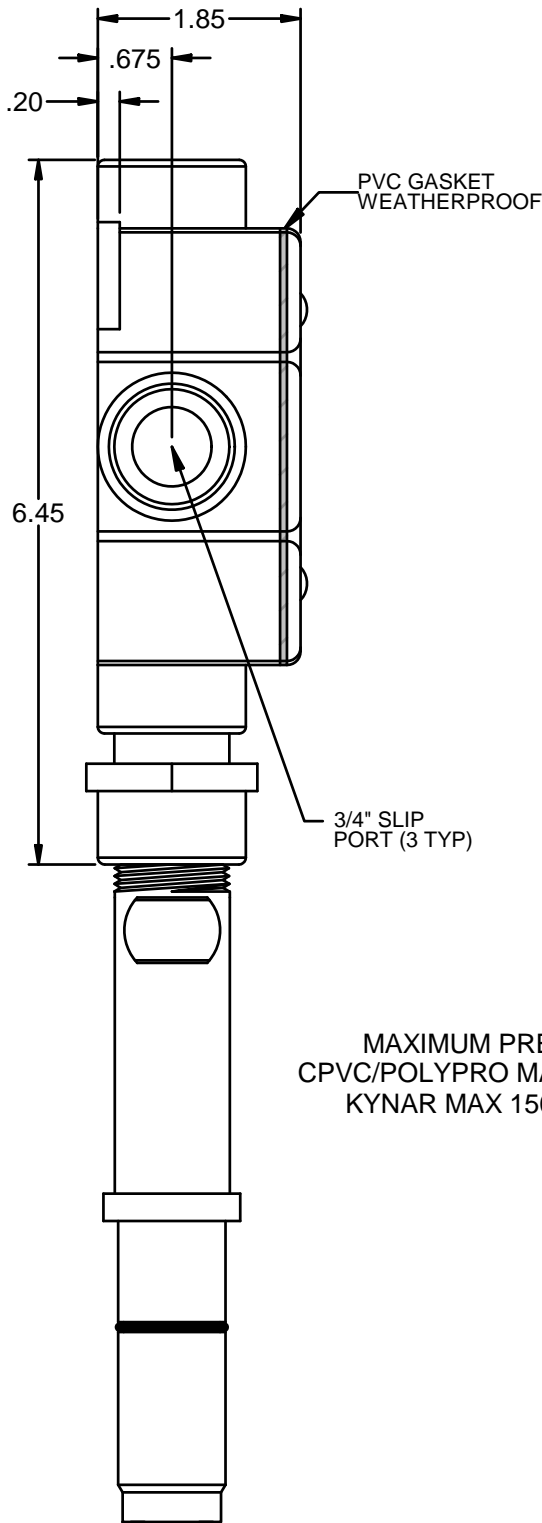

MAXIMUM PRESSURE & TEMPERATURE RATINGS
 CPVC/POLYPRO MAX 100PSIG @75°C - 35PSIG@MAX 100°C
 KYNAR MAX 150PSIG @ 70°C -40PSIG @ MAX 130°C

REVISIONS

REV	DATE	DESCRIPTION	DW N	APVD
A	02/02/01	PAGE 2, J-BOX DATA ADDED	HWM	
B	06/27/01	CPVC VERSION ADDED	HWM	
C	03/19/02	WIRING MOVED TO P0033	HWM	
D	07/19/11	UPDATE (ECO #937)	WC	HWM

DIMENSIONS IN INCHES

TOLERANCES UNLESS OTHERWISE SPECIFIED		
DECIMALS	FRACTIONS	
.0000 +/- .0005	+/- .015	
.000 +/- .005	ANGLES	
.00 +/- .010	+/- 30MIN	
.0 +/- .15		
DRAWING BY. HWM		
SCALE	DATE	SIZE
NON E	07/31/00	A

MODEL 551
pH/ORP SENSOR OUTLINE



DRAWING NO.	2P0005
CHECKED	HWM
APPROVED	HWM

PH(775)883-2500 FAX(775)297-4740