

Stratos[®] Pro A4... CONDI

Instruction Manual

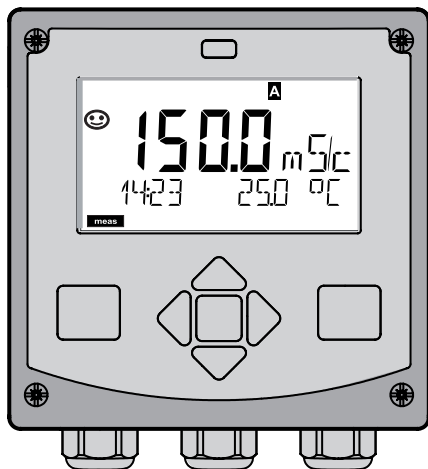

Latest Product Information:

www.knick.de



75282

Knick >

Warranty

Warranty

Defects occurring within 3 years from delivery date shall be remedied free of charge at our plant (carriage and insurance paid by sender).
Sensors, fittings, and accessories: 1 year.

Subject to change without notice.

Return of Products Under Warranty

Please contact our Service Team before returning a defective device. Ship the cleaned device to the address you have been given. If the device has been in contact with process fluids, it must be decontaminated/disinfected before shipment. In that case, please attach a corresponding certificate, for the health and safety of our service personnel.

Disposal

Please observe the applicable local or national regulations concerning the disposal of “waste electrical and electronic equipment”.



CD-ROM

Complete documentation:

- Instruction manuals
- Safety instructions
- Short instructions



Safety Information

In official EU languages and others.

- ATEX / IECEX / FM / CSA
- EC Declarations of Conformity

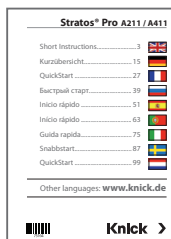

Short Instructions

In German, English, French, Russian, Spanish, Portuguese, Swedish, and Dutch. More languages on CD-ROM and on our website: www.knick.de

- Installation and commissioning
- Operation
- Menu structure
- Calibration
- Error messages and recommended actions

Specific Test Report

Contents

Documents Supplied	3
Introduction	7
Intended Use	7
Safety Information	8
Safety Precautions for Installation	9
Overview of Stratos Pro A4... CONDI	10
Assembly	11
Package Contents	11
Mounting Plan, Dimensions	12
Pipe Mounting, Protective Hood.....	13
Panel Mounting	14
Installation	15
Installation Instructions.....	15
Rating Plates / Terminal Assignments	16
Power Supply, Signal Lines.....	17
Sensor Connection	18
Cable Preparation SE 655 / SE 656.....	19
Wiring Example: SE 655 / SE 656.....	20
Wiring Example: SE 660	21
Wiring Example: Yokogawa ISC 40	22
Wiring Example: Yokogawa IC 40S	23
Wiring Example: SE 670 (via RS-485)	24
Connection of SE 670 Sensor	25
Protective Wiring of Relay Contacts.....	26
User Interface, Keypad	28
Display.....	29
Signal Colors (Display Backlighting)	29
Measuring Mode	30
Selecting the Mode / Entering Values.....	31
Operating Modes	32
Menu Structure of Modes and Functions	33
HOLD Mode	34
Alarm	35

Configuration	36
Menu Structure of Configuration.....	36
Parameter Set A/B.....	38
Configuration (Original for Copy)	44
Sensor.....	48
Current Output 1.....	54
Current Output 2.....	60
Temperature Compensation.....	62
Alarm Settings.....	66
Limit Function.....	68
Pulse Length / Pulse Frequency Controller	77
Controller	78
WASH Contact.....	82
Time and Date.....	84
Tag Number	84
Calibration	87
Selecting a Calibration Mode.....	87
Calibration with Calibration Solution.....	88
Calibration by Input of Cell Factor.....	90
Product Calibration	91
Zero Calibration in Air / with Calibration Solution.....	93
Temp Probe Adjustment	94
Measurement	95
Diagnostics	98
Service	103
Operating States.....	108
Product Line and Accessories	110
Specifications	111
Calibration Solutions	118
Concentration Curves.....	121

Contents

Error Handling	127
Error Messages	128
Sensoface	130
FDA 21 CFR Part 11	132
Electronic Signature – Passcodes.....	132
Audit Trail.....	132
Index	133
Trademarks.....	143
Passcodes	144

Intended Use

The Stratos Pro A4... CONDI is used for measurement of electrical conductivity and temperature in liquids using electrodeless (toroidal) sensors. Fields of application are: biotechnology, chemical industry, environment, food processing, water/waste-water treatment. The sturdy molded enclosure can be fixed into a control panel or mounted on a wall or at a post. The protective hood provides additional protection against direct weather exposure and mechanical damage.

The device has been designed for application with electrodeless sensors, in particular for sensors of the SE 655/656, SE 660, and SE 670 series.

Plain-text messages in a large, backlit display allow intuitive operation. The colored display backlighting signals alarm messages (red) or HOLD mode (orange).

The "Sensocheck" automatic monitoring of sensor and cables and the "Sensoface" function for clear indication of the sensor condition provide excellent diagnostics.

The internal logbook (TAN SW-A002) can handle up to 100 entries – up to 200 with AuditTrail (TAN SW-A003).

The device provides two parameter sets which can be switched manually or via a control input for different process adaptations or different process conditions. Password protection for granting access rights during operation can be configured.

Two floating, digital control inputs ("Hold" and "Control") are available for external control.

The internal PID process controller can be configured as pulse length or pulse frequency controller.

The device provides two current outputs (for transmission of measured value and temperature, for example) and four floating relay contacts. A time-controlled cleaning function can be configured.

Current is provided through a universal power supply
24 ... 230 V AC/DC, AC: 45 ... 65 Hz.

Approvals for Measurement in Hazardous Locations:

Stratos Pro A4...B CONDI: acc. to FM and CSA in Class I Div 2 / Zone 2

Safety Information

Safety information –

Be sure to read and observe the following instructions!

The device has been manufactured using state of the art technology and it complies with applicable safety regulations.

When operating the device, certain conditions may nevertheless lead to danger for the operator or damage to the device.

See also separate document:

- “Safety Instructions”.
(EC Declaration of Conformity, FM, CSA Certificates)



CAUTION!

Commissioning must only be performed by trained personnel authorized by the operating company! Whenever it is likely that protection has been impaired, the device shall be made inoperative and secured against unintended operation.

The protection is likely to be impaired if, for example:

- the device shows visible damage
- the device fails to perform the intended measurements
- after prolonged storage at temperatures above 70°C
- after severe transport stresses

Before recommissioning the device, a professional routine test must be performed. This test must be carried out at the manufacturer's factory.

Please note:

Before commissioning it must be proved that the device may be connected with other equipment.

Safety Precautions for Installation

- The electrical installation shall conform to the national regulations for electrical installations and/or other applicable national or local codes or regulations.
- The power supply shall be disconnectable from the device by a two-poled circuit breaker.
- Switch and circuit breaker shall be located in close proximity to the equipment and be easily accessible by the OPERATOR. They shall be marked as disconnect switch for the device.
- Be sure to disconnect the mains supply and any relay contacts which are connected to separate current sources before starting maintenance operations.

Approvals for application in hazardous locations

Stratos Pro A4...B CONDI: acc. to FM and CSA in Class I Div 2 / Zone 2 (pending). See also separate "Safety Instructions" document.

Terminals:

Screw terminal, suitable for single wires / flexible leads up to 2.5 mm² (AWG 14).

Recommended torque for the terminal screws: 0,5 ... 0.6 Nm.



Important Notice:

The operator must indicate the type of protection!

When the device provides different types of protection, the operator must specify the applied type of protection during installation. To do so, use the checkboxes on the rating plate:

Knick >	YY	<input checked="" type="checkbox"/> SA,08,2117513	<input type="checkbox"/> FM xxxxxxxx	
A ..X-...		IS CI I, Div 1, GRP A,B,C,D,E,F,G T4	AIS/ISI, II, III/1/ABCDEFG/T4	
No. 12345 / 1234567 / 0845		AIS CI I, II, III, Div 1, GRP A,B,C,D,E,F,G T4	NI, II, III/2/ABCDEFG/T4	
-20 ≤ T _a ≤ +65°C		CI I, Zone 1, AEx ia IIC T4	I/1/AEx ia IIC T4	
D-14163 Berlin Made in Germany		Control drawing 212,002-330	I/2/AEx nA IIC T4	
			Control drawing 212,002-300	

Additional rating plate at outside bottom of front with checkboxes for marking the respective application after installation

Overview

Overview of Stratos Pro A4... CONDI

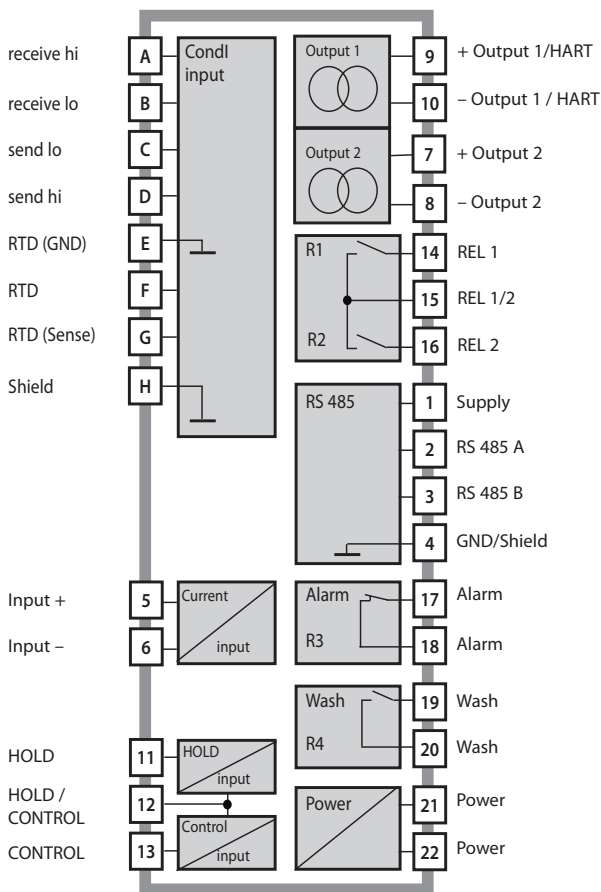

Package Contents

Check the shipment for transport damage and completeness!

The package should contain:

- Front unit, rear unit, bag containing small parts
- Specific test report
- Documentation (cf Pg 3)
- CD-ROM

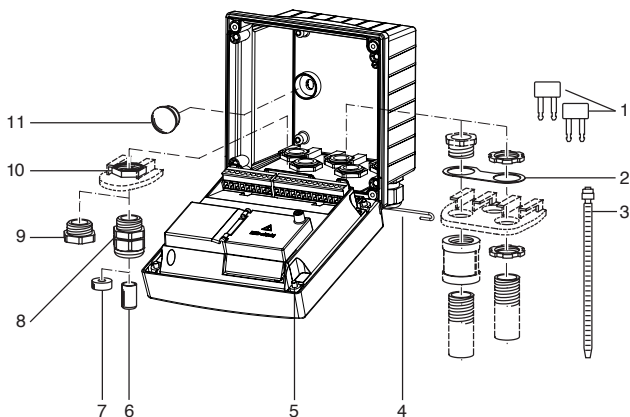
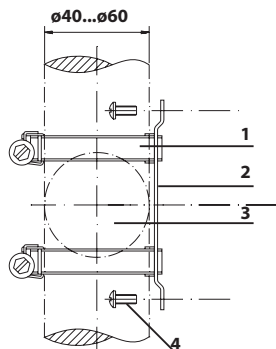

Fig.: Assembling the enclosure

- | | |
|---|--|
| 1) Jumper (3 x) | 6) Sealing insert (1 x) |
| 2) Washer (1 x), for conduit mounting: Place washer between enclosure and nut | 7) Rubber reducer (1 x) |
| 3) Cable tie (3 x) | 8) Cable gland (3 x) |
| 4) Hinge pin (1 x), insertable from either side | 9) Filler plug (3 x) |
| 5) Enclosure screw (4 x) | 10) Hexagon nut (5 x) |
| | 11) Sealing plug (2 x), for sealing in case of wall mounting |

Pipe Mounting, Protective Hood



- 1) Hose clamp with worm gear drive to DIN 3017 (2 x)
- 2) Pipe-mount plate (1 x)
- 3) For vertical or horizontal posts or pipes
- 4) Self-tapping screw (4 x)

Fig.: ZU 0274 pipe-mount kit (All dimensions in mm!)

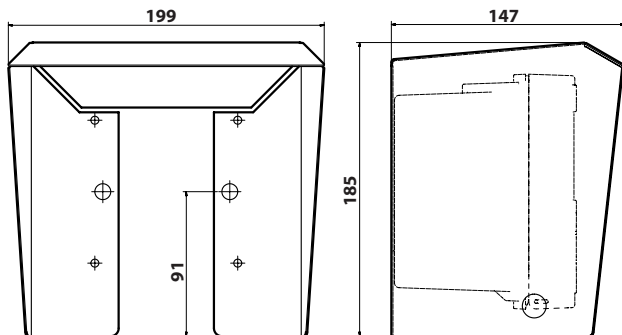

Fig.: ZU 0737 protective hood for wall and pipe mounting
(All dimensions in mm!)

Installation Instructions

- Installation of the device must be carried out by trained experts in accordance with this instruction manual and as per applicable local and national codes.
- Be sure to observe the technical specifications and input ratings during installation!
- Be sure not to notch the conductor when stripping the insulation!
- Before connecting the device to the power supply, make sure that its voltage lies within the range 20.5 to 253 V AC/DC!
- The current supplied to the current input must be galvanically isolated. If not, connect an isolator module ahead of the input!
- All parameters must be set by a system administrator prior to commissioning!

Terminals:

suitable for single wires / flexible leads up to 2.5 mm² (AWG 14)



Additional safety precautions have to be taken for operation in hazardous locations FM, CSA Cl. I Div 2 / Zone 2!
(See separate “Safety Instructions” document.)

Rating Plates / Terminal Assignments

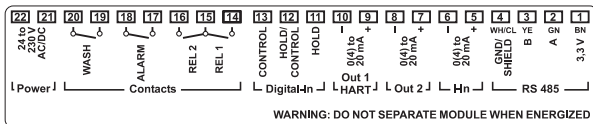

Fig.: Terminal assignments of Stratos Pro A4...

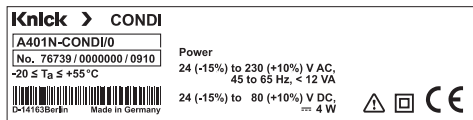

Fig.: Stratos Pro A401N-CONDI rating plate at bottom of front

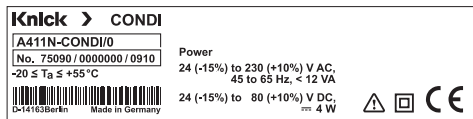

Fig.: Stratos Pro A411N-CONDI rating plate at bottom of front

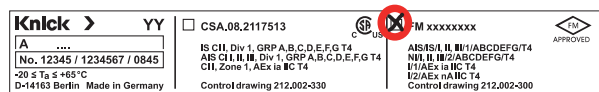

Fig.: Example of additional approval plate (cCSAus, FM)

The specifications refer to the respective device.

Important Notice:

The operator must indicate the type of protection!

When the device provides different types of protection, the operator must specify the applied type of protection during installation.

Power Supply, Signal Lines

Connect the power supply for Stratos Pro A401/A411 CONDI to terminals 21 and 22

(24 ... 230 V AC, 45 ... 65 Hz / 24 ... 80 V DC)

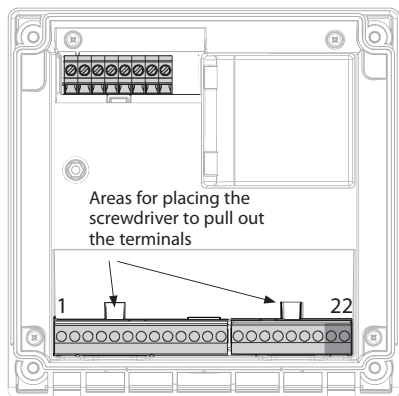

Terminal assignments

1	supply
2	RS 485 A
3	RS 485 B
4	GND/shield
5	+ input
6	- input
7	+ out 2
8	- out 2
9	+ out 1/HART
10	- out 1/HART
11	hold
12	hold/control
13	control
14	REL 1
15	REL 1/2
16	REL 2
17	alarm
18	alarm
19	wash
20	wash
21	power
22	power

Fig.: Terminals, device opened, back of front unit

Sensor Connection

Connect the sensor lines with the sensor connection (module terminals A...K).

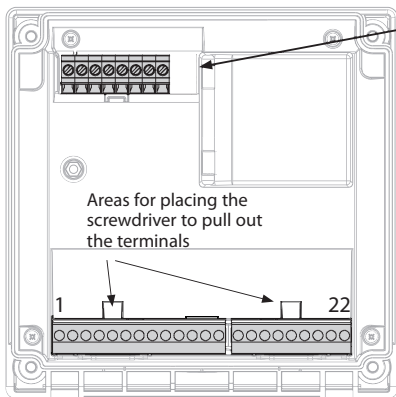

Sensor connection MK-CONDI module

A	I hi
B	V hi
C	V lo
D	I lo
E	RTD (GND)
F	RTD
G	RTD (sense)
H	Shield

Knick > Module
CONDI
Industry

Type MK-CONDI 045 XI
No. 0000000 Conductivity / °C

Siralos Pro A 2, X₄
KEMA 08 ATEX 0100
IECEx KEM08.020
FM xxxxxxxx
CSA 08.2117513

see Control dwg. 212.002-140
D-14163 Berlin 000000000000908 0944

CE APPROVED

CONDI Sensor
Temp
RTD
RTD (GND)

SHIELD

K I H G F E D C B A

Fig.: MK-CONDI module terminal assignments

Fig.: Terminals, device opened, back of front unit

Cable Preparation SE 655 / SE 656

Preparing the Shield Connection

Pre-assembled special cable for SE 655 / SE 656 sensors

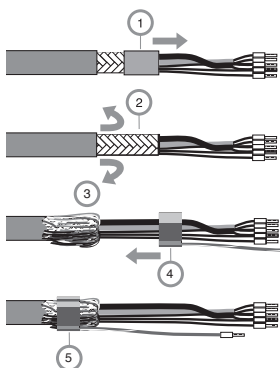

- Insert the special cable through the cable entry into the terminal compartment.
- Remove the already separated part of the cable insulation (1).
- Turn the shielding mesh (2) over the cable insulation (3).
- Then shift the crimp ring (4) over the shielding mesh and tighten it using a pincer (5)

The pre-assembled special cable:

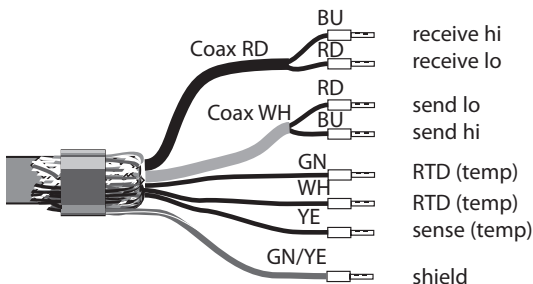

Wiring Example: SE 655 / SE 656

Measuring task: Conductivity, temperature
Sensors: SE 655/SE 656 sensor
Connecting the pre-assembled cable

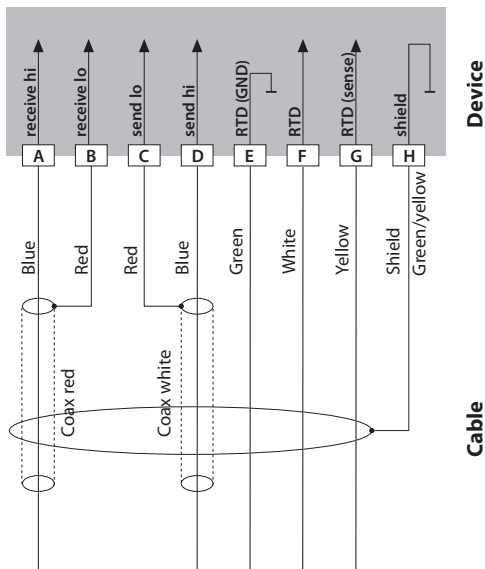

Wiring Example: SE 660

Measuring task: Conductivity, temperature
Sensor: SE 660 sensor

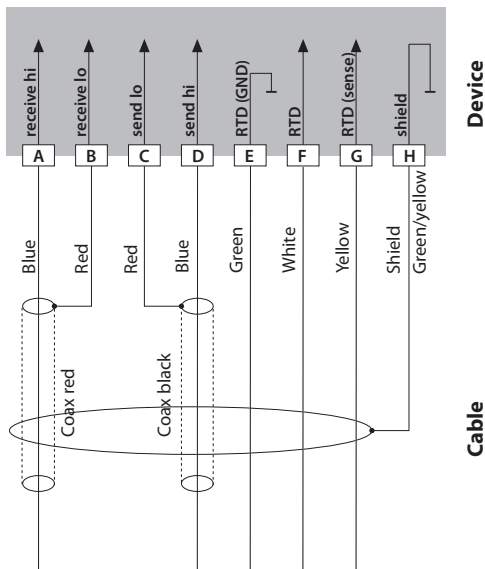

Wiring Example: Yokogawa ISC 40

Measuring task: Conductivity, temperature

Sensor: Yokogawa ISC40 (Pt 1000)

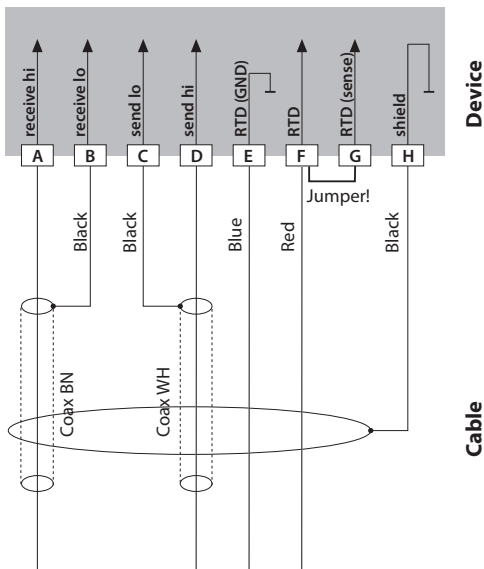

Configuration settings for this sensor:

SENSOR Conductivity, temperature

Sensor: OTHER

RTD TYPE 1000Pt

CELL FACTOR 1.88

TRANS RATIO 125

Wiring Example: Yokogawa IC 40S

Measuring task: Conductivity, temperature
Sensor: Yokogawa IC40S (NTC 30k)

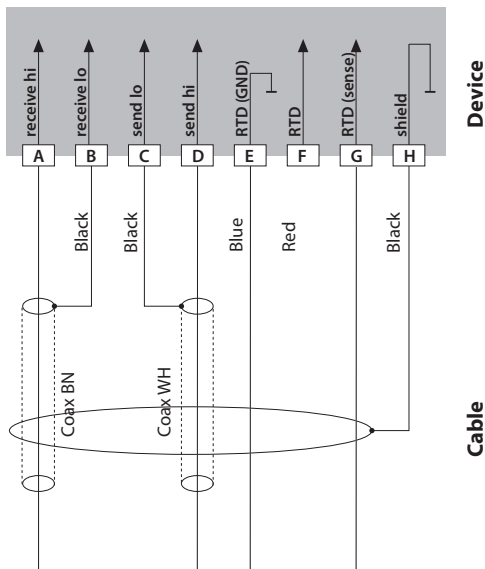

Configuration settings for this sensor:

SENSOR	Conductivity, temperature
Sensor:	OTHER
RTD TYPE	30 NTC
CELL FACTOR	Approx. 1.7
TRANS RATIO	125

Wiring Example: SE 670 (via RS-485)

Measuring task: Conductivity, temperature

Sensor: SE 670

Caution! Connection to RS-485 interface!

Remove the measuring module!

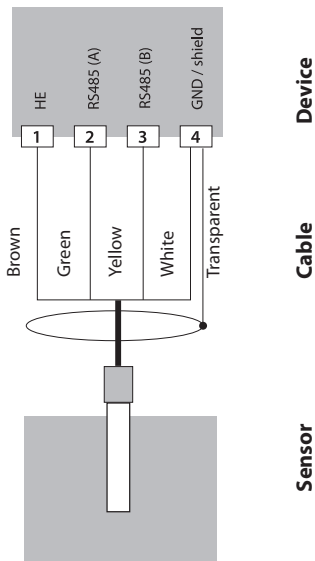

The SE 670 sensor is connected to the RS-485 interface of the device – for a A2... Series (2-wire) device, the measuring module slot must be empty. Therefore, first remove the measuring module from the slot (see next page). When the SE 670 sensor is selected in the Configuration menu, the default values are taken as calibration data. They can then be modified by calibration.

Connection of SE 670 Sensor

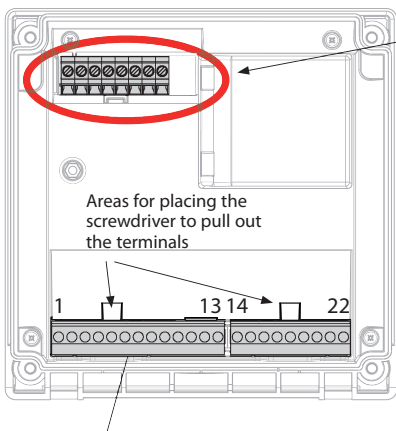

Caution!

The slot for the MK-CONDI module must be empty – be sure to remove the module!

Connection of SE 670: Wire color

1	Supply	Brown
2	RS 485 A	Green
3	RS 485 B	Yellow
4	GND/shield	White, transparent shield

Protective Wiring of Relay Contacts

Protective Wiring of Relay Contacts

Relay contacts are subject to electrical erosion. Especially with inductive and capacitive loads, the service life of the contacts will be reduced. For suppression of sparks and arcing, components such as RC combinations, nonlinear resistors, series resistors, and diodes should be used.

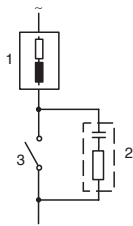
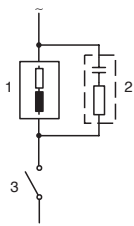

Typical AC applications with inductive load

- 1 Load
- 2 RC combination, e.g. RIFA PMR 209
Typical RC combinations for 230 V AC:
capacitor 0.1 μF / 630 V,
resistor 100 Ω / 1 W
- 3 Contact

Protective Wiring of Relay Contacts

Typical Protective Wiring Measures

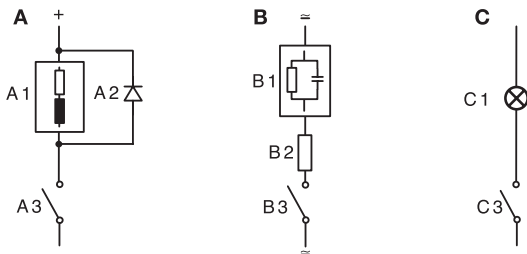

- A:** DC application with inductive load
B: AC/DC applications with capacitive load
C: Connection of incandescent lamps

- A1 Inductive load
A2 Free-wheeling diode, e.g. 1N4007 (Observe polarity)
A3 Contact
B1 Capacitive load
B2 Resistor, e.g. $8\ \Omega$ / 1 W at 24 V / 0.3 A
B3 Contact
C1 Incandescent lamp, max 60 W / 230 V, 30 W / 115 V
C3 Contact



WARNING!

Make sure that the maximum ratings of the relay contacts are not exceeded even during switching!

User Interface, Keypad

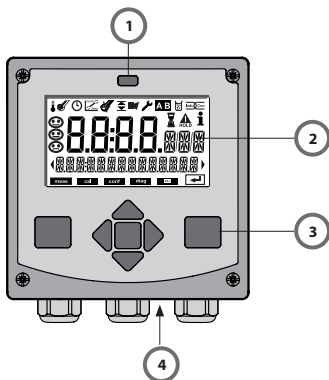

- 1 IrDA transmitter/receiver
- 2 Display
- 3 Keypad
- 4 Rating plate (bottom)

Key	Function
meas	<ul style="list-style-type: none">• Return to last menu level• Directly to measuring mode (press > 2 s)
info	<ul style="list-style-type: none">• Retrieve information• Show error messages
enter	<ul style="list-style-type: none">• Configuration: Confirm entries, next configuration step• Calibration: Continue program flow• Measuring mode: Display output current
Arrow keys up / down	<ul style="list-style-type: none">• Measuring mode: Call menu• Menu: Increase/decrease a numeral• Menu: Select
Arrow keys left / right	<ul style="list-style-type: none">• Measuring mode: Call menu• Menu: Previous/next menu group• Number entry: Move between digits

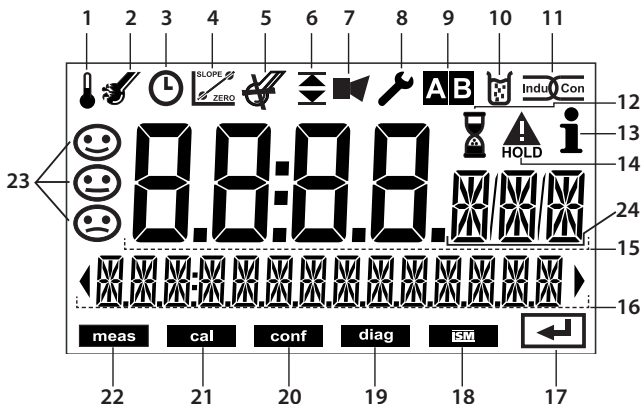

- | | |
|--------------------------|-----------------------|
| 1 Temperature | 13 Info available |
| 2 Sensocheck | 14 HOLD mode active |
| 3 Interval/response time | 15 Main display |
| 4 Sensor data | 16 Secondary display |
| 5 Not used | 17 Proceed with enter |
| 6 Limit values | 18 Not used |
| 7 Alarm | 19 Diagnostics |
| 8 Service | 20 Configuration mode |
| 9 Parameter sets A/B | 21 Calibration mode |
| 10 Calibration | 22 Measuring mode |
| 11 Digital sensor | 23 Sensoface |
| 12 Waiting time running | 24 Measurement symbol |

Signal Colors (Display Backlighting)

- | | |
|-----------|---|
| Red | Alarm |
| Orange | HOLD mode (Calibration, Configuration, Service) |
| Turquoise | Diagnostics |
| Green | Info |
| Purple | Sensoface message |

Measuring Mode

After the operating voltage has been connected and the sensor identified, the device automatically goes to "Measuring" mode. To call the measuring mode from another operating mode (e.g. Diagnostics, Service): Hold **meas** key depressed (> 2 s).

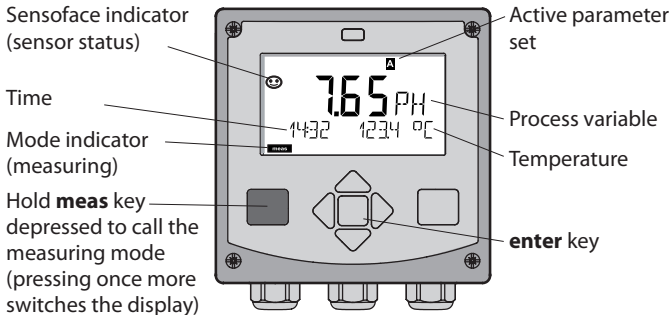

In measuring mode the display indicates:

- Measured value and time (24/12 h AM/PM) as well as temperature in °C or °F (formats selected during configuration)

By pressing the **meas** key in measuring mode you can view the following displays (for approx. 60 sec):

- Measured value and selection of parameter set A/B (if set to "Manual")
- Measured value and tag (point of measurement designation – entered during configuration)
- Time and Date
- Controller (if configured), upper display: controller output Y, lower display: Setpoint

Pressing the **enter** key shows the output currents. They are displayed as long as **enter** is held depressed, then the measured-value display will return after 3 sec.



The device must be configured for the respective measurement task!

Selecting the Mode / Entering Values

To select the operating mode:

- 1) Hold **meas** key depressed (> 2 s) (directly to measuring mode)
- 2) Press any arrow key: the selection menu appears
- 3) Select operating mode using left / right arrow key
- 4) Press **enter** to confirm the selected mode

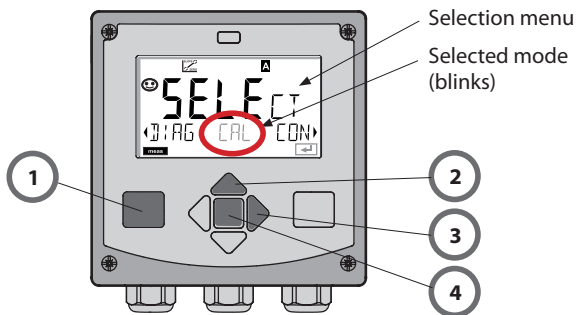

To enter a value:

- 5) Select numeral: left / right arrow key
- 6) Change numeral: up / down arrow key
- 7) Confirm entry by pressing **enter**

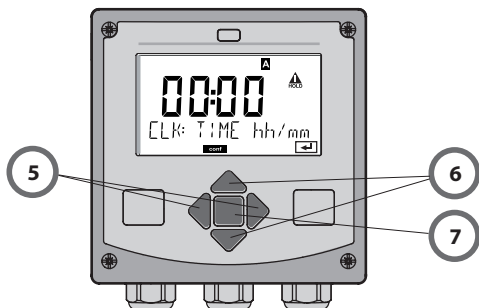

Operating Modes

Diagnostics

Display of calibration data, display of sensor data, performing a device self-test, viewing the logbook entries, display of hardware/software versions of the individual components. The logbook can store 100 events (00...99). They can be displayed directly on the device. The logbook can be extended to 200 entries using a TAN (Option).

HOLD

Manual activation of HOLD mode, e.g. for servicing. The signal outputs adopt a defined state.

Calibration

Every sensor has typical characteristic values. Calibration is required to supply a correct measured value. The device checks which value the sensor delivers when measuring in a known solution. When there is a deviation, the device can be "adjusted". In that case, the device displays the "actual" value and internally corrects the measurement error of the sensor. During calibration the device is in HOLD mode.

During calibration the analyzer remains in the HOLD mode until it is stopped by the operator.

Configuration

The analyzer must be configured for the respective measurement task. In the "Configuration" mode you select the connected sensor, the measuring range to be transmitted, and the conditions for warning and alarm messages. During configuration the device is in HOLD mode.

Configuration mode is automatically exited 20 minutes after the last keystroke. The device returns to measuring mode.

Service

Maintenance functions (current source, relay test, controller test), IrDA operation, passcode assignment, reset to factory settings, enabling of options (TAN).

Menu Structure of Modes and Functions



Pressing any arrow key opens the selection menu.
 Select the menu group using the left/right arrow keys.
 Press **enter** to open a menu. Press **meas** to return.

Measuring mode		
DIAG	CALDATA	Display of calibration data
	SENSOR	Display of sensor data
	SELFTEST	Self test: RAM, ROM, EEPROM, module
	LOGBOOK	Logbook: 100 events with date and time
	MONITOR	Display of direct, uncorrected sensor signals
	VERSION	Display of software version, model designation, serial number
HOLD		Manual activation of HOLD mode, e.g. for sensor replacement. The signal outputs behave as configured (e.g. last measured value, 21 mA)
CAL	CAL_SOL	Calibration with calibration solution
	CAL_CELL	Calibration by entry of cell factor
	CAL_ZERO	Zero calibration
	P_CAL	Product calibration
	CAL_RTD	Adjustment of temperature probe
CONF	PARSET A	Configuring parameter set A
	PARSET B	Configuring parameter set B
SERVICE (Access via code, factory setting: 5555)	MONITOR	Display of measured values for validation (simulators)
	OUT1	Current source, output 1
	OUT2	Current source, output 2
	RELAIS	Relay test
	CONTROL	Controller: manual specification of controller output
	IRDA	Activating the IrDA interface
	CODES	Specifying access codes for operating modes
	DEFAULT	Reset to factory setting
	OPTION	Enabling an option via TAN

HOLD Mode

The HOLD mode is a safety state during configuration and calibration. Output current is frozen (Last) or set to a fixed value (Fix). Alarm and limit contacts are disabled. The HOLD mode is indicated by orange display backlighting.

HOLD mode, display icon:



Output Signal Response

- **Last:** The output current is frozen at its last value. Recommended for short configuration procedures. The process should not change decisively during configuration. Changes are not noticed with this setting!
- **Fix:** The output current is set to a value that is noticeably different from the process value to signal the control system that the device is being worked at.

Output Signal During HOLD:

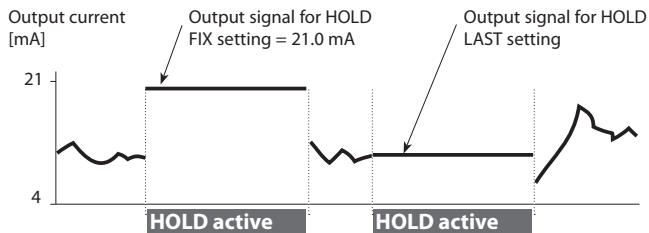

Terminating the HOLD Mode

The HOLD mode is ended by switching to measuring mode (hold **meas** key depressed). The display reads “Good Bye”, after that, the HOLD mode is exited.

When the calibration mode is exited, a confirmation prompt ensures that the installation is ready for operation (e.g.: sensor reinstalled, located in process).

External Activation of HOLD

The HOLD mode can be activated from outside by sending a signal to the Hold input (e.g. from the process control system).

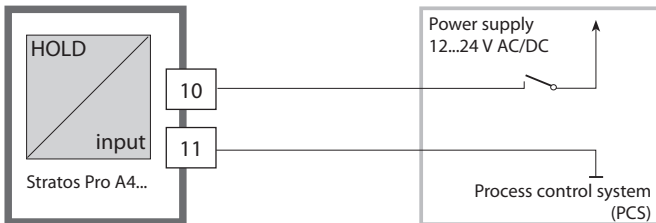

HOLD inactive	0...2 V AC/DC
HOLD active	10...30 V AC/DC

Manual Activation of HOLD

The HOLD can be activated manually from the HOLD menu. This allows checking or replacing a sensor, for example, without provoking unintended reactions of outputs or contacts. Press **meas** key to return to selection menu.

Alarm

When an error has occurred, **Err xx** is displayed immediately. Only after expiry of a user-defined delay time will the alarm be registered and entered in the logbook. During an alarm the display blinks, the display backlighting turns **red**.

Error messages can also be signaled by a 22 mA output current (see Configuration).

The alarm contact is activated by alarm and power failure, see also "Configuration / Alarm Settings".

2 sec after the failure event is corrected, the alarm status will be deleted.

Configuration

Menu Structure of Configuration

The device provides 2 parameter sets "A" and "B". By switching between the parameter sets you can adapt the device to different measurement situations, for example.

Parameter set "B" only permits setting of process-related parameters.

The configuration steps are assigned to different menu groups.

Using ◀ and ▶ you can jump between the individual menu groups.

Each menu group contains menu items for setting the parameters.

Pressing **enter** opens a menu item.

The values are edited using ▲ and ▼. Pressing **enter** confirms/stores the settings.

Return to measurement: Press **meas**.

Select menu group	Menu group	Code	Display	Select menu item
	Sensor selection	SNS:	Conf SENSOR	enter enter enter
		Menu item 1		
		Menu item ...		
▶	Current output 1	OT1:	Conf OUT 1	enter
▶	Current output 2	OT2:	Conf OUT 2	
▶	Compensation	COR:	Conf CORRECT:ON	
▶	Alarm mode	ALA:	Conf ALARM	
▶	Relay outputs	REL:	Conf REL 1/REL 2	
▶	Cleaning	WSH:	Conf WASH	◀
▶	Setting the clock	CLK:	Conf CLOCK	◀
▶	Tag number	TAG:	Conf TAG	

Parameter Set A/B: Configurable Menu Groups



(Some parameters are identical in A and B. They are configured in parameter set A only.)

Menu group	Parameter set A	Parameter set B
SENSOR	Sensor selection	---
OUT1	Current output 1	Current output 1
OUT2	Current output 2	Current output 2
CORRECTION	Compensation	Compensation
ALARM	Alarm mode	Alarm mode
REL 1/REL 2	Relay outputs	Relay outputs
WASH	Cleaning	---
PARSET	Parameter set selection	---
CLOCK	Setting the clock	---
TAG	Tag number	---

Configuration

Parameter Set A/B

Manual Selection. Signaling via WASH Contact.

Display	Action	Remark
	To switch between parameter sets: Press meas	Manual selection of parameter sets must have been preset in CONFIG mode. Default setting is a fixed parameter set A. Wrong settings change the measurement properties!
	PARSET blinks in the lower line. Select parameter set using ◀ and ▶ keys	
	Select PARSET A / PARSET B	
	Press enter to confirm. Cancel by pressing meas	

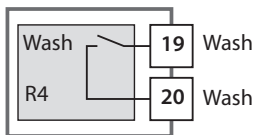

The active parameter set can be displayed using the WASH contact:

If configured correspondingly, the WASH contact signals:

“Parameter set A” (open contact)

“Parameter set B” (closed contact)

Configuration		Choices	Default
Sensor (SENSOR)			
SNS:		SE 655 SE 656 SE 660 SE 670 OTHER	SE 655
OTHER	RTD TYPE	100PT / 1000PT / 30 NTC	1000PT
	CELL FACTOR	XX.XXx	01.980
	TRANS RATIO	XXX.Xx	120.0
MEAS MODE		Cond Conc % Sal ‰	COND
Cond	MEAS RANGE	x.xxx mS/cm xx.xx mS/cm xxx.x mS/cm x.xxx S/m xx.xx S/m	x.xxx mS/cm
Conc	Solution	-01- (NaCl) -02- (HCl) -03- (NaOH) -04- (H2SO4) -05- (HNO3) -06- (H2SO4) -07- (HCl) -08- (HNO3) -09- (H2SO4) -10- (NaOH)	-01- (NaCl)
TEMP UNIT		°C / °F	°C

Configuration

Configuration		Choices	Default	
Sensor (SENSOR)				
SNS:	CIP COUNT	ON/OFF	OFF	
	SIP COUNT	ON/OFF	OFF	
Output 1 (OUT1)				
OT1:	RANGE	0–20 mA 4–20 mA	4-20 mA	
	CHANNEL	COND/TMP	COND	
	OUTPUT (with Cond only)	LIN / LOG	LIN	
	LIN	BEGIN 4mA (0 mA)	xxxx	000.0 mS/cm
		END 20 mA	xxxx	100.0 mS/cm
	LOG	BEGIN 4mA (0 mA)	Decades	
		END 20 mA	Decades	
	TMP °C	BEGIN 4mA (0 mA)	-50...200 °C	
		END 20 mA	-50...200 °C	
	TMP °F	BEGIN 4mA (0 mA)	-58...392 °F	
		END 20 mA	-58...392 °F	
	FILTERTIME	0...120 SEC	0000 SEC	
	22mA-FAIL	ON/OFF	OFF	
	HOLD MODE	LAST/FIX	LAST	
	FIX	HOLD-FIX	(0) 4...22 mA	021.0 mA

Configuration		Choices	Default	
Output 2 (OUT2)				
OT2:	RANGE		0–20 mA 4–20 mA	
	CHANNEL		CONDI/TMP	
	... other steps like output 1			
Temperature compensation (CORRECTION)				
COR:	TC SELECT		OFF LIN NLF	
	LIN	TC LIQUID	00.00...19.99%/K	
	TEMP EXT		ON/OFF	
	ON	I-INPUT		0...20 mA/4...20 mA
		°C	BEGIN 4 mA	–50...200 °C
			END 20 mA	–50...200 °C
		°F	BEGIN 4 mA	–58...392 °F
		END 20 mA	–58...392 °F	
Alarm (ALARM)				
ALA:	DELAYTIME		0...600 SEC	
	SENSOCHECK		ON/OFF	

Configuration

Configuration		Choices	Default
Relay outputs (Rel1/Rel2)			
REL	Selected in text line		LIMITS CONTROLLER
RL1	CHANNEL		COND/TMP
	FUNCTION		Lo LEVEL Hi LEVEL
	CONTACT		N/O, N/C
	LEVEL		Within meas. range
	HYSTERESIS		0...50% full scale
	DELAYTIME		0000...9999 SEC
RL2	CHANNEL		COND/TMP
	FUNCTION		Lo LEVEL Hi LEVEL
	CONTACT		N/O, N/C
	LEVEL		Within meas. range
	HYSTERESIS		0...50% full scale
	DELAYTIME		0000...9999 SEC
CTR	CHANNEL		COND/TMP
	TYPE		PLC / PFC
	PLC	PULSE LENGTH	0000...0600 SEC
	PFC	PULSE FREQ.	0000...0180 P/M
	SETPPOINT		Within meas. range
	DEAD BAND		0...50% full scale
	P-GAIN		0010...9999%
	I-TIME		0000...9999 SEC
	D-TIME		0000...9999 SEC
	HOLD MODE		Y LAST/Y OFF

Configuration		Choices	Default	
Cleaning contact (WASH)				
WSH	Selected in text line		WASH PARSET A/B	WASH
	WASH	WASH CYCLE	000.0...999.9 H	000.0 h
		WASH TIME	0000...9999 SEC	0060 SEC
		CONTACT	N/O, N/C	N/O
Parameter set (PARSET)				
PAR	Select fixed parameter set (A) or switch between A/B via control input or manually in measuring mode		PARSET FIX / CNTR INPUT / MANUAL	PARSET FIX (fixed parameter set A)
Real-time clock (CLOCK)				
CLK:	FORMAT		24 h / 12 h	
	24 h	TIME hh/mm	00..23:00...59	
	12 h	TIME hh/mm	00...11:00...59 AM/PM:	
	DAY/MONTH		01...31/01...12	
	YEAR		2000...2099	
Tag number (TAG)				
TAG:	(Input in text line)			—

Configuration (Original for Copy)

Default Settings of Parameter Sets

Two complete parameter sets are stored in the EEPROM.
As delivered, the two sets are identical but can be edited.

Please note:

Fill in your configuration data on the following pages or use them as original for copy.

Configuration (Original for Copy)

Parameter	Parameter set A	Parameter set B
SNS: Sensor type		--- *)
SNS: RTD type		---
SNS: Cell factor		---
SNS: Transfer ratio		---
SNS: Measuring mode		---
SNS: Measuring range		---
SNS: Concentration determination		---
SNS: Temperature unit		---
SNS: CIP counter		---
SNS: SIP counter		---
OT1: Current range		
OT1: Process variable		
OT1: LIN/LOG output		
OT1: Current start		
OT1: Current end		
OT1: Filter time		
OT1: 22 mA error current		
OT1: HOLD mode		
OT1: HOLD-FIX current		

*) These parameters cannot be adjusted in parameter set B, the values are the same as in parameter set A.

(Original for Copy) Configuration

Parameter	Parameter set A	Parameter set B
OT2: Current range		
OT2: Process variable		
OT2: LIN/LOG output		
OT2: Current start		
OT2: Current end		
OT2: Filter time		
OT2: 22 mA error current		
OT2: HOLD mode		
OT2: HOLD-FIX current		
COR: TC SELECT		
COR: Temp coefficient		
COR: Current range		
COR: Current start		
COR: Current end		
ALA: Delay		
ALA: Sensocheck on/off		
REL: Usage		
RL1: Process variable		
RL1: Function		
RL1: Contact response		
RL1: Setpoint		
RL1: Hysteresis		
RL1: Delay		
RL2: Process variable		
RL2: Function		
RL2: Contact response		

Configuration (Original for Copy)

Parameter	Parameter set A	Parameter set B
RL2: Setpoint		
RL2: Hysteresis		
RL2: Delay		
CTR: Process variable		
CTR: Controller type		
CTR: Pulse length		
CTR: Pulse frequency		
CTR: Setpoint		
CTR: Neutral zone		
CTR: P gain		
CTR: I time		
CTR: D time		
CTR: HOLD mode		
WSH: Contact function		---*)
WSH: Wash cycle		---*)
WSH: Wash duration		---*)
WSH: Contact response		---*)
CLK: Time & Date		---*)
TAG: Tag number		---*)

*) These parameters cannot be adjusted in parameter set B, the values are the same as in parameter set A.

Configuration

Sensor

Select: Sensor type, temperature probe, cell factor, transfer ratio, measuring mode, range



enter



enter

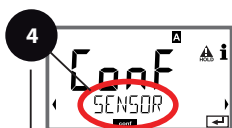

enter

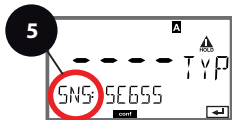





meas

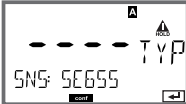

- 1 Press any arrow key.
- 2 Select **CONF** using ◀ ▶ keys, press **enter**.
- 3 Select parameter set using ◀ ▶ keys, press **enter**.
- 4 Select **SENSOR** menu using ◀ ▶ keys, press **enter**.
- 5 All items of this menu group are indicated by the "SNS:" code. Press **enter** to select menu, edit with arrow keys (see next page). Confirm (and proceed) with **enter**.
- 6 End: Press **meas** key until the [meas] mode indicator is displayed.

5

Sensor type	enter
Temp probe	enter
Cell factor	enter
Transfer ratio	
Measuring mode	
Range	
Concentration determination	
Temperature unit	
Cleaning cycles	
Sterilization cycles	

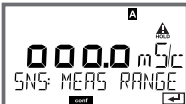
Menu item	Action	Choices
<p>Sensor type</p> 	<p>Select sensor type using ▲ ▼ keys.</p> <p>Press enter to confirm.</p>	<p>SE 655 SE 656 SE 660 SE 670 OTHER</p>
<p>Temp probe</p> 	<p>Only with OTHER: Select type of temperature probe using ▲ ▼ keys. Press enter to confirm.</p>	<p>1000PT 100PT</p>
<p>Cell factor</p> 	<p>Enter cell factor using ▲ ▼ ◀ ▶ keys. Press enter to confirm.</p>	<p>01.980 XX.XXX</p>
<p>Transfer ratio</p> 	<p>Enter transfer ratio using ▲ ▼ ◀ ▶ keys. Press enter to confirm.</p>	<p>120.00 XXX.Xx</p>
<p>Measuring mode</p> 	<p>Select desired measuring mode using ▲ ▼ keys.</p> <p>Press enter to confirm.</p>	<p>Cond Conc % Sal %o</p>
<p>Range</p> 	<p>For cond measurement only</p> <p>Select desired range using ▲ ▼ keys.</p> <p>Press enter to confirm.</p>	<p>x.xxx mS/cm, xx.xx mS/cm xxx.x mS/cm, x.xxx S/m xx.xx S/m</p>

Configuration

Sensor

Select: Concentration determination, temperature unit



enter



enter

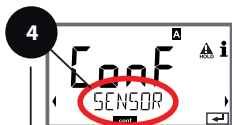

enter

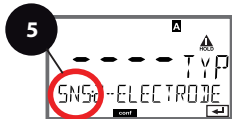

meas



- 1 Press any arrow key.
- 2 Select **CONF** using ◀ ▶ keys, press **enter**.
- 3 Select parameter set using ◀ ▶ keys, press **enter**.
- 4 Select **SENSOR** menu using ◀ ▶ keys, press **enter**.
- 5 All items of this menu group are indicated by the "SNS:" code.
Press **enter** to select menu, edit with arrow keys (see next page). Confirm (and proceed) with **enter**.
- 6 End: Press **meas** key until the [meas] mode indicator is displayed.

5

Sensor type	enter
Temp probe	
Cell factor	
Transfer ratio	
Measuring mode	
Range	
Concentration determination	
Temperature unit	
Cleaning cycles	
Sterilization cycles	

Menu item	Action	Choices
Concentration determination	<p>For conc measurement only</p> <p>Select desired concentration solution using ▲ ▼ (see appendix for ranges).</p> <p>Press enter to confirm.</p>	<p>-01- (NaCl) -02- (HCl) -03- (NaOH) -04- (H₂SO₄) -05- (HNO₃) -06- (H₂SO₄) -07- (HCl) -08- (HNO₃) -09- (H₂SO₄) -10- (NaOH)</p>
Temperature unit	<p>Select °C or °F using ▲ ▼ keys.</p> <p>Press enter to confirm.</p>	°C / °F

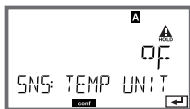
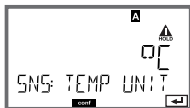

Configuration

Sensor

Adjust: Cleaning cycles, sterilization cycles



enter



enter

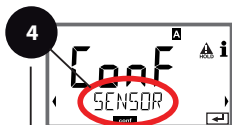

enter

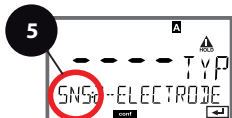



meas



- 1 Press any arrow key.
- 2 Select **CONF** using ◀ ▶ keys, press **enter**.
- 3 Select parameter set using ◀ ▶ keys, press **enter**.
- 4 Select **SENSOR** menu using ◀ ▶ keys, press **enter**.
- 5 All items of this menu group are indicated by the "SNS:" code. Press **enter** to select menu, edit with arrow keys (see next page). Confirm (and proceed) with **enter**.
- 6 End: Press **meas** key until the [meas] mode indicator is displayed.

5

Sensor type	enter
Temp probe	
Cell factor	
Transfer ratio	
Measuring mode	
Range	
Concentration determination	
Temperature unit	
Cleaning cycles	
Sterilization cycles	

Menu item	Action	Choices
CIP / SIP		
Cleaning cycles On / Off 	Select ON or OFF using ▲ ▼ keys. Activates/deactivates log- ging in extended logbook Press enter to confirm.	ON/OFF
Sterilization cycles On / Off 	Select ON or OFF using ▲ ▼ keys. Activates/deactivates log- ging in extended logbook Press enter to confirm.	ON/OFF

Please note:

A CIP or SIP cycle is only entered into the logbook 2 hours after the start to ensure that the cycle is complete.

Configuration

Current Output 1

Output current range, linear/logarithmic, current start.



enter



enter

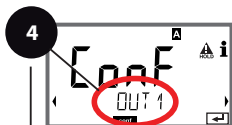

enter







meas



- 1 Press any arrow key.
- 2 Select **CONF** using ◀ ▶ keys, press **enter**.
- 3 Select parameter set using ◀ ▶ keys, press **enter**.
- 4 Select **OUT1** menu using ◀ ▶ keys, press **enter**.
- 5 All items of this menu group are indicated by the "OT1:" code.
Press **enter** to select menu, edit with arrow keys (see next page). Confirm (and proceed) with **enter**.
- 6 End: Press **meas** key until the [meas] mode indicator is displayed.

5

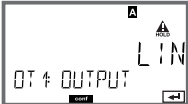
Current range	enter
Process variable	enter
Linear/Logarithmic	enter
Current start	
Current end	
Time averaging filter	
Output current during error message	
Output current during HOLD	
Output current for HOLD FIX	

Menu item	Action	Remark
Process variable 	Select using \uparrow \downarrow keys: Cond: Conductivity TMP: Temperature Press enter to confirm.	Cond/TMP 
Select LIN/LOG: 	Select using \uparrow \downarrow keys: LIN: Linear characteristic LOG: Logarithmic – See right column for selectable decades. Press enter to confirm.	Selectable decades with logarithmic setting (LOG): S/cm: 0.001 mS/cm, 0.01 mS/cm, 0.1 mS/cm, 1.0 mS/cm, 10.0 mS/cm, 100.0 mS/cm, 1000 mS/cm S/m: 0.001 S/m, 0.01 S/m, 0.1 S/m, 1.0 S/m, 10.0 S/m, 100 S/m
Current start 	Modify digit using \uparrow \downarrow keys, select next digit using \leftarrow \rightarrow keys. Press enter to confirm.	As selected for process variable/range If the adjusted range is exceeded, the device automatically switches to the next higher range (Autorange)
Current end 	Enter value using \uparrow \downarrow \leftarrow \rightarrow keys. Press enter to confirm.	As selected for process variable/range If the adjusted range is exceeded, the device automatically switches to the next higher range (Autorange)

Assignment of measured values: Current start and current end

Example 1: Range 0...200 mS/cm

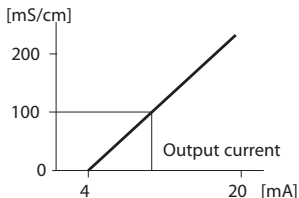

Example 2: Range 100...200 mS/cm

Advantage: Higher resolution in range of interest

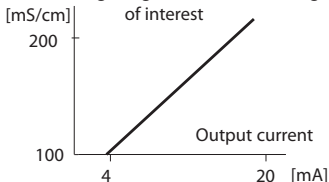

Configuration

Current Output 1

Current end, time interval of output filter



enter



enter

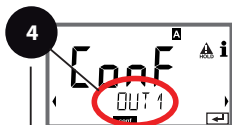

enter



meas



- 1 Press any arrow key.
- 2 Select **CONF** using ◀ ▶ keys, press **enter**.
- 3 Select parameter set using ◀ ▶ keys, press **enter**.
- 4 Select **OUT1** menu using ◀ ▶ keys, press **enter**.
- 5 All items of this menu group are indicated by the "OT1:" code.
Press **enter** to select menu, edit with arrow keys (see next page). Confirm (and proceed) with **enter**.
- 6 End: Press **meas** key until the [meas] mode indicator is displayed.

5

Current range	enter
Process variable	enter
Linear/Logarithmic	enter
Current start	
Current end	
Time averaging filter	
Output current during error message	
Output current during HOLD	
Output current for HOLD FIX	

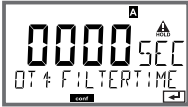
Menu item	Action	Choices
Current end 	Enter value using ▲ ▼ ◀ ▶ keys. Press enter to confirm.	As selected for process variable/range
Time averaging filter 	Enter value using ▲ ▼ ◀ ▶ keys. Press enter to confirm.	0...120 SEC (0000 SEC)

Time averaging filter (attenuation)

To smoothen the current output, a low-pass filter with adjustable filter time constant can be switched on. When there is a jump at the input (100 %), the output level is at 63 % after the time interval has been reached.

The time interval can be set from 0 to 120 sec.

If the time interval is set to 0 sec, the current output directly follows the input.

Please note:

The filter only acts on the current output, not on the display, the limit values, or the controller!

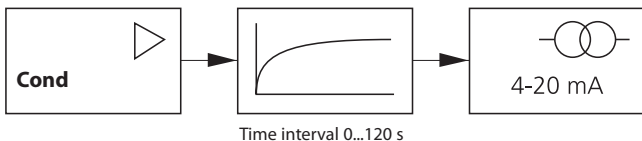

Configuration

Current Output 1

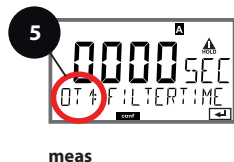
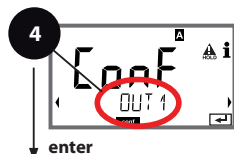

Output current during Error and HOLD



- 1 Press any arrow key.
- 2 Select **CONF** using ◀ ▶ keys, press **enter**.
- 3 Select parameter set using ◀ ▶ keys, press **enter**.
- 4 Select **OUT1** menu using ◀ ▶ keys, press **enter**.
- 5 All items of this menu group are indicated by the "OT1:" code. Press **enter** to select menu, edit with arrow keys (see next page). Confirm (and proceed) with **enter**.
- 6 End: Press **meas** key until the [meas] mode indicator is displayed.

5

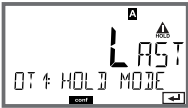
Current range	↔ enter
Process variable	↔
Linear/Logarithmic	↔
Current start	
Current end	
Time averaging filter	
Output current during error message	
Output current during HOLD	
Output current for HOLD FIX	

Menu item	Action	Choices
Output current during error message	Select ON or OFF using \blacktriangle \blacktriangledown keys. Press enter to confirm.	ON/OFF
		
Output current during HOLD	LAST: During HOLD the last measured value is maintained at the output. FIX: During HOLD a value (to be entered) is maintained at the output. Select using \blacktriangle \blacktriangledown Press enter to confirm.	LAST/FIX
		
Output current for HOLD FIX	Only with FIX selected: Enter current which is to flow at the output during HOLD Enter value using \blacktriangle \blacktriangledown \blacktriangleleft \blacktriangleright keys. Press enter to confirm.	00.00...21.00 mA
		

Output Signal During HOLD:

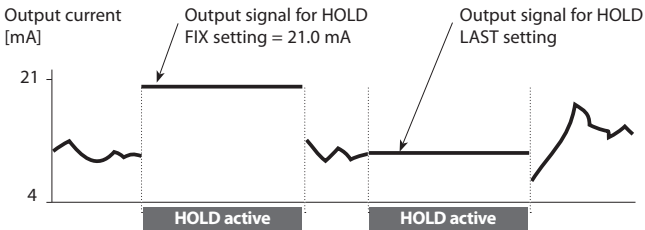

Configuration

Current Output 2

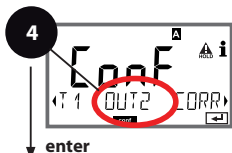

Current range, process variable ...



- 1 Press any arrow key.
- 2 Select **CONF** using ◀ ▶ keys, press **enter**.
- 3 Select parameter set using ◀ ▶ keys, press **enter**.
- 4 Select **OUT2** menu using ◀ ▶ keys, press **enter**.
- 5 All items of this menu group are indicated by the "OT2:" code.
Press **enter** to select menu, edit with arrow keys (see next page). Confirm (and proceed) with **enter**.
- 6 End: Press **meas** key until the [meas] mode indicator is displayed.

5

Current range	enter
Process variable	enter
Current start	
Current end	
Time averaging filter	
Output current during error message	
Output current during HOLD	
Output current for HOLD FIX	

Menu item	Action	Choices
Current range	Select 4-20 mA or 0-20 mA range using ▲ ▼ keys.	4-20 mA / 0-20 mA
	Press enter to confirm.	
Process variable	Select using ▲ ▼ keys: Cond: Conductivity TMP: Temperature	Cond/TMP Begin: 0 °C End: 100°C
	Press enter to confirm.	
.		
.		
.		

All the following adjustments are made as for current output 1 (see there)!

Temperature Compensation Selecting the compensation method



enter



enter



enter



meas



- 1 Press any arrow key.
- 2 Select **CONF** using ◀ ▶ keys, press **enter**.
- 3 Select parameter set using ◀ ▶ keys, press **enter**.
- 4 Select **CORRECTION** menu using ◀ ▶ keys, press **enter**.
- 5 All items of this menu group are indicated by the "COR:" code. Press **enter** to select menu, edit with arrow keys (see next page). Confirm (and proceed) with **enter**.
- 6 End: Press **meas** key until the [meas] mode indicator is displayed.



5 Temperature compensation

Current input for external temperature measurement

Current start

Current end

enter

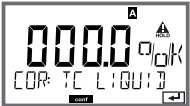

Menu item	Action	Choices
Temperature compensation	<p>Select desired compensation using \blacktriangle \blacktriangledown keys:</p> <p>OFF: Temperature compensation switched off</p> <p>LIN: Linear temperature compensation with entry of temperature coefficient.</p> <p>nLF: Temperature compensation for natural waters to EN 27888</p> <p>Press enter to confirm.</p>	  
Temp compensation, process medium 	<p>With linear compensation only: Enter temperature compensation of the process medium. Enter value using \blacktriangle \blacktriangledown \blacktriangleleft \blacktriangleright keys. Press enter to confirm.</p>	0...19.99 %/K 02.00 %/K

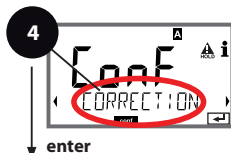
Temperature Compensation Current input for temp measurement

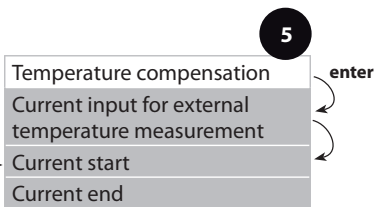

- 1 Press any arrow key.
- 2 Select **CONF** using ◀ ▶ keys, press **enter**.
- 3 Select parameter set using ◀ ▶ keys, press **enter**.
- 4 Select **CORRECTION** menu using ◀ ▶ keys, press **enter**.
- 5 All items of this menu group are indicated by the "COR:" code. Press **enter** to select menu, edit with arrow keys (see next page). Confirm (and proceed) with **enter**.
- 6 End: Press **meas** key until the [meas] mode indicator is displayed.



Menu item	Action	Choices
Current range	Select desired range using \blacktriangle \blacktriangledown keys. Press enter to confirm.	4-20 mA / 0-20 mA
		
Current start	Modify digit using \blacktriangle \blacktriangledown keys, select next digit using \blacktriangleleft \blacktriangleright keys. Press enter to confirm.	Input range: -50...200 °C / -58...392 °F
		
Current end	Enter value using \blacktriangle \blacktriangledown \blacktriangleleft \blacktriangleright keys. Press enter to confirm.	Input range: -50...200 °C / -58...392 °F
		

Configuration

Alarm Settings

Delay, Sensocheck



enter



enter



enter



meas





- 1 Press any arrow key.
- 2 Select **CONF** using ◀ ▶ keys, press **enter**.
- 3 Select parameter set using ◀ ▶ keys, press **enter**.
- 4 Select **ALARM** menu using ◀ ▶ keys, press **enter**.
- 5 All items of this menu group are indicated by the "ALA:" code. Press **enter** to select menu, edit with arrow keys (see next page). Confirm (and proceed) with **enter**.
- 6 End: Press **meas** key until the [meas] mode indicator is displayed.

Delay

Sensocheck

5

enter

Menu item	Action	Choices
Delay 	Enter value using ▲ ▼ ◀ ▶ keys. Press enter to confirm.	0...600 SEC (010 SEC)
Sensocheck 	Select Sensocheck (continuous monitoring of sensor). Select ON or OFF using ▲ ▼ keys. Press enter to confirm (At the same time, Sensoface is activated. With OFF, Sensoface is also switched off.)	ON/OFF

Alarm Contact

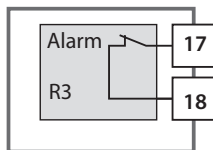

The alarm contact is closed during normal operation (N/C).

It opens in the case of alarm or power outage.

As a result, a failure message is provided even in the case of line breakage (fail-safe behavior).

For contact ratings, see Specifications.

Error messages can also be signaled by a 22 mA output current (see Error messages and Configuration Output 1/Output 2).

Operating behavior of the alarm contact: see Operating States table.

The alarm delay time delays the color change of the display back-lighting to red, the 22 mA signal (if configured), and the alarm contact switching.

Configuration

Limit Function

Relay 1



enter



enter



enter







meas

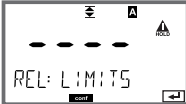

- 1 Press any arrow key.
- 2 Select **CONF** using ◀ ▶ keys, press **enter**.
- 3 Select parameter set using ◀ ▶ keys, press **enter**.
- 4 Select **REL1/REL2** menu using ◀ ▶ keys, press **enter**.
- 5 All items of this menu group are indicated by the "RL1:" code. Press **enter** to select menu, edit with arrow keys (see next page). Confirm (and proceed) with **enter**.
- 6 End: Press **meas** key until the [meas] mode indicator is displayed.

5

Use of relays	enter
Select process variable	↔
Limit 1 function	↔
Limit 1 contact type	
Limit 1 setpoint	
Limit 1 hysteresis	
Limit 1 delay	

Menu item	Action	Choices
<p>Use of relays</p> 	<p>Select in the text line using ▲ ▼ keys:</p> <ul style="list-style-type: none"> • Limit function (LIMITS) • Controller (CONTROLLER) <p>Press enter to confirm.</p>	<p>LIMITS / CONTROLLER</p> <p>Please note: Selecting CONTROLLER leads to Controller menu group CTR.</p>
<p>Select process variable</p> 	<p>Select desired process variable using ▲ ▼ keys.</p> <p>Press enter to confirm.</p>	<p>Cond/TMP</p>
<p>Limit 1 function</p> 	<p>Select desired function using ▲ ▼ keys.</p> <p>LoLevel: active if value falls below / HiLevel: active if value exceeds setpoint</p> <p>Press enter to confirm.</p>	<p>Lo LEVEL / Hi LEVEL</p>
<p>Limit 1 contact response</p> 	<p>N/O: normally open contact N/C: normally closed contact</p> <p>Select using ▲ ▼ keys. Press enter to confirm.</p>	<p>N/O / N/C</p>
<p>Limit 1 setpoint</p> 	<p>Enter setpoint using ▲ ▼ ◀ ▶ keys.</p> <p>Press enter to confirm.</p>	<p>Within meas. range</p>

Limit Function

Relay 1



enter



enter



enter





meas

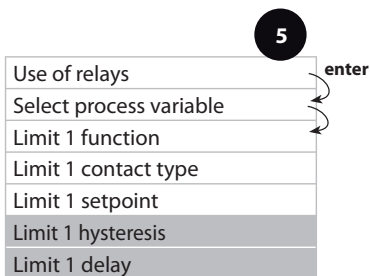

- 1 Press any arrow key.
- 2 Select **CONF** using ◀ ▶ keys, press **enter**.
- 3 Select parameter set using ◀ ▶ keys, press **enter**.
- 4 Select **REL1/REL2** menu using ◀ ▶ keys, press **enter**.
- 5 All items of this menu group are indicated by the "RL1:" code. Press **enter** to select menu, edit with arrow keys (see next page). Confirm (and proceed) with **enter**.
- 6 End: Press **meas** key until the [meas] mode indicator is displayed.

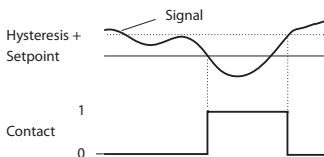
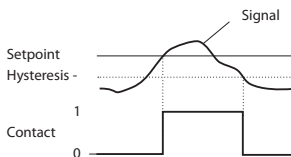

Menu item	Action	Choices
Limit 1 hysteresis 	Select hysteresis using ▲ ▼ ◀ ▶ keys. Press enter to confirm.	0...50% full scale
Limit 1 delay 	The contact is activated with delay (deactivated without delay) Adjust delay using ▲ ▼ ◀ ▶ keys. Press enter to confirm.	0...9999 SEC (0010 SEC)

Limit Lo**Limit Hi**

Configuration

Limit Function

Relay 2



- 1 Press any arrow key.
- 2 Select **CONF** using ◀ ▶ keys, press **enter**.
- 3 Select parameter set using ◀ ▶ keys, press **enter**.
- 4 Select **REL1/REL2** menu using ◀ ▶ keys, press **enter**.
- 5 All items of this menu group are indicated by the "RL2:" code. Press **enter** to select menu, edit with arrow keys (see next page). Confirm (and proceed) with **enter**.
- 6 End: Press **meas** key until the [meas] mode indicator is displayed.

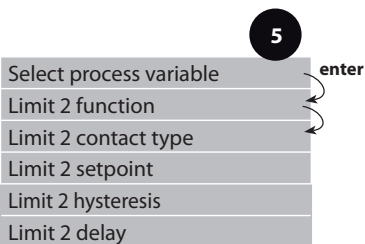

Menu item	Action	Choices
Select process variable (CHANNEL)	Select desired process variable using \blacktriangle \blacktriangledown keys. Press enter to confirm.	Cond/TMP
Limit 2 function (FUNCTION)	Select desired function using \blacktriangle \blacktriangledown keys. Press enter to confirm.	Lo LEVEL / Hi LEVEL
Limit 2 contact type (CONTACT)	N/O: normally open contact N/C: normally closed contact Select using \blacktriangle \blacktriangledown keys. Press enter to confirm.	N/O / N/C
Limit 2 setpoint (LEVEL)	Enter setpoint using \blacktriangle \blacktriangledown \blackleftarrow \blackrightarrow keys. Press enter to confirm.	Within meas. range
Limit 2 hysteresis (HYSTERESIS)	Select hysteresis using \blacktriangle \blacktriangledown \blackleftarrow \blackrightarrow keys. Press enter to confirm.	0...50% full scale
Limit 2 delay (DELAYTIME)	The contact is activated with delay (deactivated without delay) Adjust delay using \blacktriangle \blacktriangledown \blackleftarrow \blackrightarrow keys. Press enter to confirm.	0...9999 SEC (0010 SEC)

Limit Lo

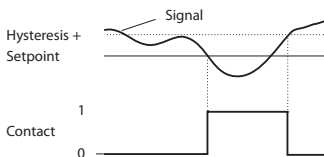

Limit Hi

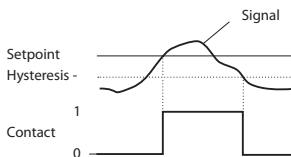

Typical Applications

P Controller

Application for integrating control systems (e.g. closed tank, batch processes).

PI Controller

Application for non-integrating control systems (e.g. drains).

PID Controller

The additional derivative action compensates for measurement peaks.

Controller Characteristic

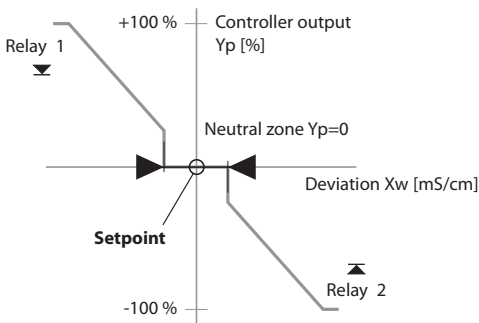

Controller Functions

Controller Equations

$$\text{Controller output } Y = Y_P + \frac{1}{T_R} \int Y_P dt + T_D \frac{dY_P}{dt}$$

P action I action D action

Proportional action Y_P

$$Y_P = \frac{\text{Setpoint} - \text{Meas. value}}{\text{Measuring range}} * K_C$$

with:
 Y_P Proportional action
 T_R Reset time [s]
 T_D Rate time [s]
 K_C Controller gain [%]

Neutral zone (Y=0)

Tolerated deviation from desired value.

With the setting "1 mS/cm", for example, a deviation of ± 0.5 mS/cm from the desired value does not activate the controller.

Proportional action (Gradient K_C [%])

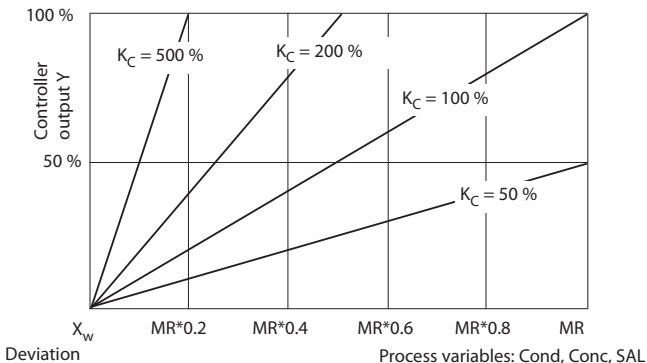

Pulse Length / Pulse Frequency Controller

Pulse Length Controller (PLC)

The pulse length controller is used to operate a valve as an actuator. It switches the contact on for a time that depends on the controller output. The period is constant. A minimum ON time of 0.5 sec is maintained even if the controller output takes corresponding values.

Output signal (relay contact) of pulse length controller

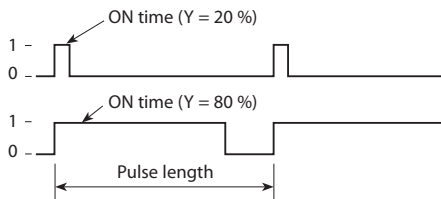

Pulse Frequency Controller (PFC)

The pulse frequency controller is used to operate a frequency-controlled actuator (metering pump). It varies the frequency with which the contacts are switched on. The maximum pulse frequency [pulses/min] can be defined. It depends on the actuator. The contact ON time is constant. It is automatically calculated from the user-defined maximum pulse frequency:

Output signal (relay contact) of pulse frequency controller

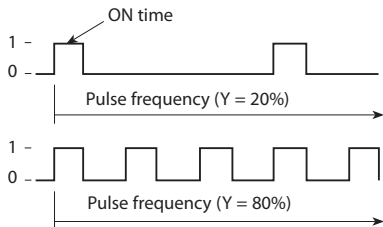

Configuration

Controller

(For description, see Controller Functions)

Process variable, controller type, setpoint



enter



enter



enter







meas



- 1 Press any arrow key.
- 2 Select **CONF** using ◀ ▶ keys, press **enter**.
- 3 Select parameter set using ◀ ▶ keys, press **enter**.
- 4 Select **REL1/REL2** menu using ◀ ▶ keys, press **enter**.
- 5 All items of this menu group are indicated by the "CTR:" code.
Press **enter** to select menu, edit with arrow keys (see next page). Confirm (and proceed) with **enter**.
- 6 End: Press **meas** key until the [meas] mode indicator is displayed.

5

Select process variable	enter
Controller type	↔
Pulse length	↔
Pulse frequency	
Setpoint	
Neutral zone	
Controller: P action	
Controller: I action	
Controller: D action	
Behavior during HOLD	

Menu item	Action	Choices
Select process variable 	Select desired process variable using ▲ ▼ keys. Press enter to confirm.	Cond/TMP
Controller type 	Pulse length controller (PLC) or pulse frequency controller (PFC) Select using ▲ ▼ keys. Press enter to confirm.	PLC / PFC
Pulse length 	Only with PLC: Pulse length Adjust using ▲ ▼ ◀ ▶ keys. Press enter to confirm.	0...0600 SEC (0010 SEC)
Pulse frequency 	Only with PFC: Pulse frequency Adjust using ▲ ▼ ◀ ▶ keys. Press enter to confirm.	0...0180 P/M (0060 P/M) (pulses per minute)
Setpoint 	Adjust setpoint using ▲ ▼ ◀ ▶ keys. Press enter to confirm.	Within meas. range If the adjusted range is exceeded, the device automatically switches to the next higher range (Autorange)

Configuration

Controller





(For description, see Controller Functions)

Neutral zone, P, I, D actions, behavior during HOLD

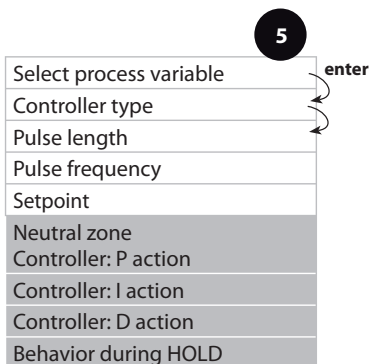

- 1 Press any arrow key.
- 2 Select **CONF** using ◀ ▶ keys, press **enter**.
- 3 Select parameter set using ◀ ▶ keys, press **enter**.
- 4 Select **REL1/REL2** menu using ◀ ▶ keys, press **enter**.
- 5 All items of this menu group are indicated by the "CTR:" code. Press **enter** to select menu, edit with arrow keys (see next page). Confirm (and proceed) with **enter**.
- 6 End: Press **meas** key until the [meas] mode indicator is displayed.



Menu item	Action	Choices
Neutral zone	Adjust neutral zone using ▲ ▼ ◀ ▶ keys.	0...50 % full scale If the adjusted range is exceeded, the device automatically switches to the next higher range (Autorange)
	Press enter to confirm.	
Controller: P action	Adjust P action using ▲ ▼ ◀ ▶ keys.	10...9999 % (0100 %)
	Press enter to confirm.	
Controller: I action	Adjust I action using ▲ ▼ ◀ ▶ keys.	0...9999 SEC (0000 SEC)
	Press enter to confirm.	
Controller: D action	Adjust D action using ▲ ▼ ◀ ▶ keys.	0...9999 SEC (0000 SEC)
	Press enter to confirm.	
Behavior during HOLD	Select response using ▲ ▼ keys.	Y LAST / Y OFF
	Press enter to confirm.	

Configuration

WASH Contact

Control of rinsing probes or signaling the parameter set



enter



enter



enter



meas



- 1 Press any arrow key.
- 2 Select **CONF** using ◀ ▶ keys, press **enter**.
- 3 Select parameter set A using ◀ ▶ keys, press **enter**.
- 4 Select **WASH** menu using ◀ ▶ keys, press **enter**.
- 5 All items of this menu group are indicated by the "WSH:" code. Press **enter** to select menu, edit with arrow keys (see next page). Confirm (and proceed) with **enter**.
- 6 End: Press **meas** key until the [meas] mode indicator is displayed.

5





Function

Cleaning interval

Cleaning duration

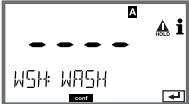
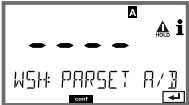
Contact type

enter

Menu item	Action	Choices
Function  	Select WASH contact function using \blacktriangle \blacktriangledown keys. Press enter to confirm.	WASH / PARSET A/B WASH: Control of rinsing probes With PARSET A/B selected, the contact signals: "Parameter set A" (open contact) "Parameter set B" (closed contact)
Cleaning interval 	Only with WASH: Adjust value using \blacktriangle \blacktriangledown \blacktriangleleft \blacktriangleright keys. Press enter to confirm.	0.0...999.9 h (000.0 h)
Cleaning duration 	Only with WASH: Adjust value using \blacktriangle \blacktriangledown \blacktriangleleft \blacktriangleright keys. Press enter to confirm.	0..9999 SEC (0060 SEC)
Contact type 	Only with WASH: N/O: normally open contact N/C: normally closed contact Select using \blacktriangle \blacktriangledown keys. Press enter to confirm.	N/O / N/C

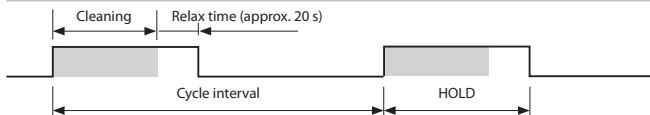

Configuration

Time and Date Tag Number



enter



enter



enter



meas



- 1 Press any arrow key.
- 2 Select **CONF** using ◀ ▶ keys, press **enter**.
- 3 Select parameter set A using ◀ ▶ keys, press **enter**.
- 4 Press **enter**
- 5 Select **CLOCK** or **TAG** using ◀ ▶ keys, press **enter**.
- 6 All items of this menu group are indicated by the "CLK:" or "TAG" code. Press **enter** to select menu, edit with arrow keys (see next page). Confirm (and proceed) with **enter**.
- 7 End: Press **meas** key until the [meas] mode indicator is displayed.

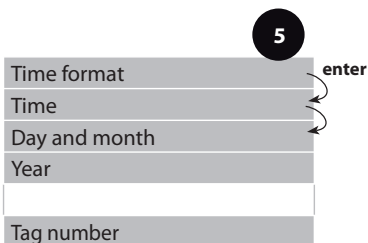

Time and Date

Control of the calibration and cleaning cycles is based on the time and date of the integrated real-time clock.

In measuring mode the time is shown in the lower display.

When using digital sensors, the calibration data is written in the sensor head.

In addition, the logbook entries (cf Diagnostics) are provided with a time stamp.

Please note:

- After prolonged power outage (> 5 days) the time display is replaced by dashes and cannot be used for processing. Enter the correct time.
- There is no automatic switchover from winter to summer time! Be sure to manually adjust the time!

Tag Number ("TAG")

You can enter a designation for the point of measurement (tag number) in the lower display line. Up to 32 digits are possible.

Pressing **meas** (repeatedly) in the measuring mode indicates the tag number.

Being part of the device configuration, the "TAG" can be read out via IrDA.

A standardized tag number helps, for example, to correctly re-install a device after repair.

5

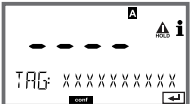
Menu item	Action	Choices
Tag number 	Select character using ▲ ▼ keys, select next digit using ◀ ▶ keys. Press enter to confirm.	A...Z, 0...9, - + < > ? / @ The first 10 characters are seen in the display with- out scrolling.

Please note:

- All calibration procedures must be performed by trained personnel. Incorrectly set parameters may go unnoticed, but change the measuring properties.

Calibration can be performed by:

- Determining the cell factor with a known calibration solution taking account of the temperature
- Input of cell factor (e.g. for ultrapure-water sensors)
- Sampling (product calibration)
- Zero calibration in air or with calibration solution
- Temperature probe adjustment

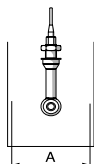

Please note:

If measurements are performed in fittings with $A < 110$ mm, be sure to choose a calibration beaker with the same cross-section and of the same material (metal/plastic)!

Selecting a Calibration Mode

Calibration adapts the device to the individual sensor characteristics. Access to calibration can be protected with a passcode (SERVICE menu).

First, you open the calibration menu and select the calibration mode:

CAL_SOL	Calibration with calibration solution
CAL_CELL	Calibration by entry of cell factor
P_CAL	Product calibration (calibration with sampling)
CAL_ZERO	Zero calibration
CAL_RTD	Temperature probe adjustment

Calibration



Calibration with Calibration Solution



Input of temperature-corrected value of calibration solution with simultaneous display of cell factor.

Be sure to use known calibration solutions and the respective temperature-corrected conductivity values (see calibration solution tables in the appendix). During the calibration procedure the temperature must be kept constant.

Please note:

When using an ARF 210/215 flow-through fitting, you should use the included calibration beakers (identical dimensions and materials) for calibration to prevent calibration errors.





Display	Action	Remark
	Select Calibration. Press enter to proceed. Select CAL_SOL calibration method. Press enter to proceed.	
	Ready for calibration. Hourglass blinks.	Display (3 sec) Now the device is in HOLD mode.
	Immerse sensor in calibration solution. Enter the temperature-corrected value of the calibration solution using the arrow keys (see table in the appendix). Press enter to confirm.	Lower line: display of cell factor and temperature

Display	Action	Remark
	<p>The cell factor and zero point are displayed. The "hourglass" icon is blinking.</p>	
	<p>Use the arrow keys to select:</p> <ul style="list-style-type: none"> • Repeat (repeat calibration) or • Measuring. <p>Press enter to confirm.</p>	
	<p>With MEAS selected: End calibration by pressing enter.</p>	<p>Display of measured variable, Sensoface is active.</p> <p>After end of calibration, the outputs remain in HOLD mode for a short time.</p> <p>After display of GOOD BYE, the device automatically returns to measuring mode.</p>

Calibration

Calibration by Input of Cell Factor

You can directly enter the value for the cell factor of a sensor. This value must be known, e.g. determined beforehand in the laboratory. The selected process variable and the temperature are displayed. This method is suitable for all process variables.

Display	Action	Remark
	Select Calibration. Press enter to proceed. Select CAL_CELL calibration method. Press enter to proceed.	
	Ready for calibration. Hourglass blinks.	Display (3 sec) Now the device is in HOLD mode.
	Enter cell factor. Press enter to proceed.	The selected process variable and the temperature are displayed.
	The device shows the calculated cell factor and zero point (at 25 °C). Sensoface is active.	
	Use the arrow keys to select: <ul style="list-style-type: none">• MEAS (end)• REPEAT Press enter to proceed.	End: HOLD is deactivated after a short time.

Please refer to the Specifications for the nominal cell factor. When measuring in a restricted space, the individual cell factor must be determined.

Product Calibration

(Calibration by sampling)

For product calibration, the uncompensated conductivity (mS/cm, S/m) is used. During product calibration the sensor remains in the process. The measurement process is only interrupted briefly.

Procedure:



1) The sample is measured in the lab or directly on the site using a portable meter. To ensure an exact calibration, sample temperature and process temperature should be the same.

During sampling the device saves the currently measured value and then returns to measuring mode. Then, the “calibration” mode indicator blinks.







2) In the second step you enter the measured sample value in the device. From the difference between the stored measured value and entered sample value, the device calculates the new cell factor.

If the sample is invalid, you can take over the value stored during sampling. In that case the old calibration values are stored.





Afterwards, you can start a new product calibration.

Display	Action	Remark
	Select Calibration. Press enter to proceed. Select P_CAL calibration method. Press enter to proceed.	
	Ready for calibration. Hourglass blinks.	Display (3 sec) Now the device is in HOLD mode.
	Take sample and save value. Press enter to proceed.	Now the sample can be measured in the lab.

Calibration





Display	Action	Remark
	The device returns to measuring mode.	From the blinking CAL mode indicator you see that product calibration has not been terminated.
	Product calibration step 2: When the sample value has been determined, open the product calibration once more	Display (3 sec) Now the device is in HOLD mode.
	The stored value is displayed (blinking) and can be overwritten with the lab value. Press enter to proceed.	
	Display of new cell factor and zero point (based on 25°C). Sensoface is active. Press enter .	To repeat calibration: Select REPEAT, then enter
	To end calibration: Select MEAS, then enter	
	After calibration is ended, the device will switch to measuring mode.	After end of calibration, the outputs remain in HOLD mode for a short time.



Zero Calibration in Air / with Calibration Solution

Display	Action	Remark
	Select Calibration. Press enter to proceed. Select CAL_ZERO calibration method. Press enter to proceed.	
	Ready for calibration. Hourglass blinks.	Display (3 sec) Now the device is in HOLD mode.
	Calibration in air. Edit digits until the lower display indicates Zero Calibration with solution Edit digits until the lower display indicates the solution value Press enter to proceed.	
	The device shows the cell factor (at 25 °C) and the zero point. Sensiface is active.	
	Use the arrow keys to select: • MEAS (end) • REPEAT Press enter to proceed.	End: HOLD is deactivated after a short time.

Calibration

Temp Probe Adjustment

Display	Action	Remark
	Select Calibration. Press enter to proceed. Select CAL_RTD calibration method. Press enter to proceed.	Wrong settings change the measurement properties!
	Measure the temperature of the process medium using an external thermometer.	Display (3 sec) Now the device is in HOLD mode.
	Enter the measured temperature value. Maximum difference: 10 K. Press enter to proceed.	Display of actual temperature (uncompensated) in the lower display.
	The corrected temperature value is displayed. Sensoface is active. To end calibration: Select MEAS, then enter To repeat calibration: Select REPEAT, then enter	After end of calibration, the outputs remain in HOLD mode for a short time.
	After calibration is ended, the device will switch to measuring mode.	

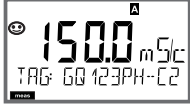
Display	Remark
	<p>From the configuration or calibration menus, you can switch the device to measuring mode by pressing the meas key.</p> <p>In the measuring mode the main display shows the configured process variable, the secondary display shows the time and the second configured process variable. The [meas] mode indicator lights and the active parameter set (A/B) is indicated. A/B is not displayed with parameter set Fix A.</p>
<p>or AM/PM and °F:</p>	<p>Please note:</p> <ul style="list-style-type: none"> • After prolonged power outage (> 5 days) the time display is replaced by dashes and cannot be used for processing. Enter the correct time.
	<p>Pressing the enter key briefly shows the output currents. By pressing the meas key you can step through the following displays. When no key has been pressed for 60 sec, the device returns to the standard display.</p>
	<p>Selecting the parameter set (if set to "manual" in the configuration). Select the desired parameter set using the ◀ ▶ arrow keys (PARSET A or PARSET B blinks in the lower display line). Press enter to confirm.</p>
	<p>Further displays (each with meas).</p> <ol style="list-style-type: none"> 1) Display of tag number ("TAG") 2) Display of time and date

Measurement

Display	Remark
<p>With activated controller you can also step through the following displays by pressing the meas key. When no key has been pressed for 60 sec, the device returns to the standard display.</p>	
 <p>The image shows a digital LCD display. The main display shows '50.00' with a small 'A' symbol above it. To the left is a smiley face icon, and to the right is a warning triangle icon. Below the main display, there are two smaller icons and the text '5000 mS'. At the bottom left, there is a small 'meas' label, and at the bottom right, there is a left-pointing arrow icon.</p>	<p>Main display: Controller output Y Secondary display: Setpoint Depending on configuration setting: conductivity or temperature.</p>

Diagnostics

In the Diagnostics mode you can access the following menus without interrupting the measurement:



CALDATA	Viewing the calibration data
SENSOR	Viewing the sensor data
SELFTEST	Starting a device self-test
LOGBOOK	Viewing the logbook entries
MONITOR	Displaying currently measured values
VERSION	Displaying device type, software version, serial number

Access to diagnostics can be protected with a passcode (SERVICE menu).

Please note:

HOLD is not active during Diagnostics mode!

Action	Key	Remark
Activate Diagnostics		Press any arrow key to call the selection menu. (Display color changes to turquoise.) Select DIAG using ◀ ▶ keys, press enter to confirm.
Select diagnostics option		Use ◀ ▶ keys to select from: CALDATA SENSOR SELFTEST LOGBOOK MONITOR VERSION See next pages for further proceeding.
End	meas	End by pressing meas .

Menu item	Remark
	<p>Display of calibration data</p> <p>Select CALDATA using \leftarrow \rightarrow, press enter to confirm. Use the \leftarrow \rightarrow keys to select the desired parameter from the bottom line of the display (LAST_CAL CELLFACTOR ZERO). The selected parameter is shown in the main display.</p>
	<p>Press meas to return to measurement.</p>

Diagnostics

Display









Menu item

Device self-test

(To abort, you can press **meas**.)

- Display test:** Display of all segments with changing background colors white/green/red. Press **enter** to proceed.
- RAM test:** Hourglass blinks, then display of --PASS-- or --FAIL--
Press **enter** to proceed.
- EEPROM test:** Hourglass blinks, then display of --PASS-- or --FAIL--
Press **enter** to proceed.
- FLASH test:** Hourglass blinks, then display of --PASS-- or --FAIL--
Press **enter** to proceed.
- Module test:** Hourglass blinks, then display of --PASS-- or --FAIL--
Press **enter** or **meas** to return to measuring mode.

Menu item	Remark
	<p>Display of logbook entries. Select LOGBOOK using ◀ ▶, press enter to confirm.</p> <p>By using the ▲ ▼ keys, you can scroll backwards and forwards through the logbook (entries -00...-99), -00- being the last entry.</p>
	<p>By using the ◀ ▶ keys, you can view a logbook entry.</p>
	<p>Press meas to return to measurement.</p>
	<p>Extended logbook / Audit Trail (via TAN) By using the ▲ ▼ keys, you can scroll backwards and forwards through the extended logbook (entries -000...-199), -000- being the last entry.</p> <p>Display: CFR Audit Trail also records function activations (CAL CONFIG SERVICE), some Sensoface messages, and opening of the enclosure.</p>
	<p>Display of currently measured values (sensor monitor): Select MONITOR using ◀ ▶, press enter to confirm. Use the ◀ ▶ keys to select the desired parameter from the bottom line of the display (R_COND G_COND RTD TEMP I-INPUT (Option)). The selected parameter is shown in the main display.</p>
<p>Display example:</p>	<p>Press meas to return to measurement.</p>
	

Diagnostics



Display	Remark
 A screenshot of a diagnostic display. The display shows '1.0.2 SW' in large digits at the top. Below it, 'SERIAL-NO 0073' is displayed. There are navigation arrows on the left and right sides of the display area.	<p>Version</p> <p>Here, you find the data you require for requesting a device-specific Option.</p> <p>Display of device type, software/hardware version, and serial number for all device components.</p> <p>Use the ▲ ▼ keys to switch between software and hardware version. Press enter to proceed to next device component.</p>





In the Service mode you can access the following menus:



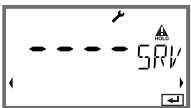

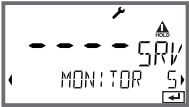
MONITOR	Displaying currently measured values
OUT1	Testing current output 1
OUT2	Testing current output 2
RELAY	Testing the function of the 4 relays
CONTROL	Testing the controller function
IRDA	Activating and communicating via the IrDA interface
CODES	Assigning and editing passcodes
DEFAULT	Resetting the device to factory settings
OPTION	Enabling options via TAN.

Please note:

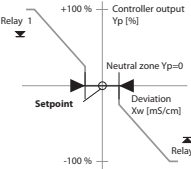

HOLD is active during Service mode!

Action	Key/Display	Remark
Activate Service		Press any arrow key to call the selection menu. Select SERVICE using ◀ ▶ keys, confirm with enter
Passcode		Enter passcode "5555" for service mode using the ▲ ▼ ◀ ▶ keys. Press enter to confirm.
Display		In service mode the following icons are displayed: <ul style="list-style-type: none"> • HOLD triangle • Service (wrench)
End	meas	End with meas .

Menu item	Remark
 <p>Display example:</p> 	<p>Display of currently measured values (sensor monitor) with HOLD mode activated: Select MONITOR using ◀ ▶, press enter to confirm. Select variable in the bottom text line using ◀ ▶.</p> <p>The selected parameter is shown in the main display. As the device is in HOLD mode, you can perform validations using simulators without influencing the signal outputs.</p> <p>Press meas to return to the service menu. Return to measurement: Press meas once more.</p>
	<p>Specify current at outputs 1 and 2: Select OUT1 or OUT2 using the ◀ ▶ keys, press enter to confirm. Enter a valid current value for the respective output using ▲ ▼ ◀ ▶ keys. Press enter to confirm. For checking purposes, the actual output current is shown in the bottom right corner of the display. End by pressing enter or meas.</p>
 <p>REL1 REL2 ALARM WASH</p>	<p>Relay test (manual test of contacts): Select RELAIS using ◀ ▶, press enter to confirm. Now the status of the 4 relays is "frozen". The 4 digits of the main display represent the respective states (from left to right: REL1, REL2, ALARM, WASH). The digit for the selected relay blinks. Select one of the 4 relays using the ◀ ▶ keys, close (1) or open (0) using the ▲ ▼ keys. End by pressing enter. The relays will be re-set corresponding to the measured value.</p> <p>Press meas to return to measurement.</p>



Menu item	Remark
 <p>Controller characteristic</p>  <p>The arrows indicate which relay (valve) is active:</p> <ul style="list-style-type: none"> ▲ Relay 2 active (Meas. value > setpoint) ▼ Relay 2 active (Meas. value < setpoint) 	<p>Controller test (manual specification of controller output): This function is used to start up control loops or check the actuators. For bumpless changeover to automatic operation (exiting this function), configure an I-action component (reset time).</p> <p>The lower display shows the currently adjusted controller output Yp.</p> <p>Specify new value for controller output Yp: Enter sign and value in the main display using the ▲ ▼ ◀ ▶ keys. Press enter to confirm.</p> <p>The new value is taken into the lower display.</p> <p>Press enter or meas to return to the service menu. Return to measurement: Press meas once more.</p> <p>Controller output -100...0% Relay 2 active</p> <p>Controller output 0...+100% Relay 1 active</p>
	<p>IrDA communication: Select IRDA using ◀ ▶ , press enter to confirm.</p>
 	<p>When IrDA communication is active, the device remains in the HOLD mode for reasons of safety. Further operation is performed via IrDA.</p> <p>End communication by pressing meas.</p> <p>Exception: Firmware update (must not be interrupted!)</p>

Service

Menu item	Remark
	<p>Assigning passcodes: In the "SERVICE - CODES" menu you can assign passcodes to DIAG, HOLD, CAL, CONF, and SERVICE modes (Service preset to 5555).</p> <p>When you have lost the Service passcode, you have to request an "Ambulance TAN" from the manufacturer specifying the serial number of your device. To enter the "Ambulance TAN", call the Service function and enter passcode 7321. After correct input of the ambulance TAN the device signals "PASS" for 4 sec and resets the Service passcode to 5555.</p>
	<p>Reset to factory settings: In the "SERVICE - DEFAULT" menu you can reset the device to factory settings.</p> <p>Caution! After a reset to factory setting the device must be reconfigured completely, including the sensor parameters!</p>
	<p>Option request: Communicate the serial number and hardware/software version of your device to the manufacturer. These data can be viewed in the Diagnostics/Version menu.</p> <p>The "transaction number" (TAN) you will then receive is only valid for the device with the corresponding serial number.</p> <p>Release of options: Options come with a "transaction number" (TAN). This TAN must be entered and confirmed using enter to release the option.</p>

Operating States

Operating status	OUT 1	OUT 2	REL1/2 (Limit)	REL1/2 (Control)	ALARM contact	WASH contact	Time out
Measuring							-
Diag							60 s
CAL_SOL Cal solution							No
CAL_CELL Cell factor							No
P_CAL Product cal S1							No
P_CAL Product cal S2							No
CAL RTD Temp adjustm.							20 min
CONF ParSet A							20 min
CONF ParSet B							20 min
CONF Passcodes							20 min
SERVICE MONITOR							20 min
SERVICE OUT 1							20 min
SERVICE OUT 2							20 min
SERVICE RELAIS							20 min
SERVICE CONTROL							20 min
SERVICE IRDA	22 mA						20 min

Operating status	OUT 1	OUT 2	REL1/2 (Limit)	REL1/2 (Control)	ALARM contact	WASH contact	Time out
Cleaning fct							No
HOLD input							No

Explanation:  as configured (Last/Fix or Last/Off)

 active

 manual

Product Line and Accessories

Order Code Stratos Pro A 4...

						Channel 1	Channel 2	TAN
Example	A	4	1	1	N	- PH	/ 0	
4-wire / 20...254 V AC/DC	A	4						B,C,E
Communication								
Without (HART retrofittable via TAN)			0					A
HART			1					
Version number								
Version				1				
Approvals								
General Safety					N			
ATEX / IECEX / FM / CSA Zone 2 / CI 1 Div 2					B			
Meas. channel 1 / Meas. channel 2								
Memosens pH (ORP)				Digital	MSPH	0		
Memosens pH (ORP) / pH (ORP)				Digital	MSPH	MSPH		
Memosens pH (ORP) / Oxy				Digital	MSPH	MSOXY		
Memosens COND				Digital	MSCOND	0		
Memosens COND / COND				Digital	MSCOND	MSCOND		
Memosens Oxy				Digital	MSOxy	0		
Dual COND (2x2-electrode, analog)				Module	CC	0		
pH / ORP value (ISM digital: TAN)				Module	PH	0		F
Cond, 2-/4-electrode				Module	COND	0		
Conductivity, electrodeless				Module	CONDI	0		
Oxygen (ISM digital/Traces: TAN)				Module	OXY	0		D, F
Carbon dioxide (ISM digital: TAN)				Module	CO2	0		F
TAN options								
HART					SW-A001			(A)
Logbook					SW-A002			(B)
Extended logbook (Audit Trail)					SW-A003			(C)
Trace oxygen measurement					SW-A004			(D)
Current input + 2 digital inputs					SW-A005			(E)
ISM digital					SW-A006			(F)
Mounting accessories								
Pipe-mount kit					ZU 0274			
Protective hood					ZU 0737			
Panel-mount kit					ZU 0738			

Specifications

CONDI input	Input for electrodeless conductivity sensors SE 655, SE 656, SE 660, SE 670	
Effective ranges	Conductivity	0.000 ... 1999 mS/cm
	Concentration	0.00 ... 100.0% by wt
	Salinity	0.0 ... 45.0 ‰ (0 ... 35 °C)
Ranges	Conductivity	0.000 ... 9.999 mS/cm (not with SE 660 / SE 670) 00.00 ... 99.99 mS/cm 000.0 ... 999.9 mS/cm 0000 ... 1999 mS/cm 0.000 ... 9.999 S/cm 00.00 ... 99.99 S/cm
	Concentration	0.00 ... 9.99 % / 10.0 ... 100.0 %
	Salinity	0.0 ... 45.0 ‰ (0 ... 35 °C)
	Response (T90)	Approx. 1 s
Meas. error^{1,2,3)}	< 1 % meas. val. + 0.005 mS	
Temp compensation ¹⁾ (reference temp 25°C)	(OFF)	Without
	(LIN)	Linear characteristic 00.00 ... 19.99 %/K
	(NLF)	Natural waters to EN 27888
Concentration determination	-01- NaCl	0 - 26% by wt (0 °C) ... 0 - 28% by wt (100 °C)
	-02- HCl	0 - 18% by wt (-20 °C) ... 0 - 18% by wt (50 °C)
	-03- NaOH	0 - 13% by wt (0 °C) ... 0 - 24% by wt (100 °C)
	-04- H ₂ SO ₄	0 - 26% by wt (-17 °C) ... 0 - 37% by wt (110 °C)
	-05- HNO ₃	0 - 30% by wt (-20 °C) ... 0 - 30% by wt (50 °C)
	-06- H ₂ SO ₄	94 - 99% by wt (-17 °C) ... 89 - 99% by wt (115 °C)
	-07- HCl	22 - 39% by wt (-20 °C) ... 22 - 39% by wt (50 °C)
	-08- HNO ₃	35 - 96% by wt (-20 °C) ... 35 - 96% by wt (50 °C)
	-09- H ₂ SO ₄	28 - 88% by wt (-17 °C) ... 39 - 88% by wt (115 °C)
	-10- NaOH	15 - 50% by wt (0 °C) ... 35 - 50% by wt (100 °C)

Specifications

Sensor standardization	Input of cell factor with simultaneous display of selected process variable and temperature Input of calibration solution conductivity with simultaneous display of cell factor Product calibration for conductivity Zero adjustment Temperature probe adjustment
Permitted cell factor	00.100 ... 19.999
Permitted transfer ratio	010.0 ... 199.99
Permitted zero offset	± 0.5 mS
Sensocheck	Monitoring of primary and secondary coils and lines for open circuit and of primary coil and lines for short circuit
Delay	Approx. 30 s
Sensoface	Provides information on the sensor condition (zero point, Sensocheck)
Sensor monitor	Direct display of measured values from sensor for validation (resistance/temperature)
Temperature input *	Pt100/Pt1000/NTC 30 kΩ 3-wire connection, adjustable
Measuring range	Pt 100/Pt 1000 -50 ... +200 °C / -58 ... +392 °F NTC 30 kΩ -20 ... +150 °C / -4 ... +302 °F
Resolution	0.1 °C / 0.1 °F
Meas. error ^{1,2,3)}	< 0.5 K (< 1 K for Pt 100; < 1K for NTC >100°C)
I input (TAN)	Current input 0/4 ... 20 mA / 50 Ω for external temperature signal
Start/end of scale	Configurable -50 ... +200 °C / -58 ... +392 °F
Characteristic	Linear
Measurement error ^{1,3)}	< 1% current value + 0.1 mA

HOLD input	Galvanically separated (OPTO coupler)	
Function	Switches device to HOLD mode	
Switching voltage	0 ... 2 V (AC/DC)	HOLD inactive
	10 ... 30 V (AC/DC)	HOLD active
CONTROL input	Galvanically separated (OPTO coupler)	
Function	Selecting parameter set A/B	
Switching voltage	0 ... 2 V (AC/DC)	Parameter set A
	10 ... 30 V (AC/DC)	Parameter set B
Output 1	0/4 ... 20 mA, max. 10 V, floating (galv. connected to output 2)	
Process variable*	Conductivity, concentration, salinity, or temperature	
Characteristic	Linear or logarithmic	
Overrange*	22 mA in the case of error messages	
Output filter*	PT ₁ filter, time constant 0 ... 120 s	
Measurement error ¹⁾	< 0.25 % current value + 0.025 mA	
Start/end of scale*	Configurable within selected range	
Minimum span	LIN	5% of selected range
	LOG	1 decade
Output 2	0/4 ... 20 mA, max. 10 V, floating (galv. connected to output 1)	
Process variable*	Conductivity, concentration, salinity, or temperature	
Characteristic	Linear or logarithmic	
Overrange*	22 mA in the case of error messages	
Output filter*	PT ₁ filter, time constant 0 ... 120 s	
Measurement error ¹⁾	< 0.25 % current value + 0.025 mA	
Start/end of scale*	Configurable within selected range	
Minimum span	LIN	5% of selected range
	LOG	1 decade

Specifications

Alarm contact	Relay contact, floating
Contact ratings	AC < 250 V / < 3 A / < 750 VA
	DC < 30 V / < 3 A / < 90 W
Contact response	N/C (fail-safe type)
Response delay	0000 ... 0600 sec
Wash contact	Relay contact, floating For controlling a cleaning system
Contact ratings	AC < 250 V / < 3 A / < 750 VA
	DC < 30 V / < 3 A / < 90 W
Contact response*	N/C or N/O
Interval*	000.0 ... 999.9 h (000.0 h = cleaning function switched off)
Cleaning time*	0000 ... 1999 s
or	
Parameter set A/B	For signaling parameter set A/B
Contact ratings	AC < 250 V / < 3 A / < 750 VA
	DC < 30 V / < 3 A / < 90 W
Contact response*	Contact open: Parameter set A active
	Contact closed: Parameter set B active
Limit values Rel1/Rel2	Rel1/Rel2 contacts, floating, but inter-connected
Contact ratings	AC < 250 V / < 3 A / < 750 VA
	DC < 30 V / < 3 A / < 90 W
Contact response*	N/C or N/O
Response delay*	0000 ... 9999 s
Switching points*	As desired within range
Hysteresis*	User-defined

PID process controller	Output via Rel1/Rel2 relay contacts (see limit values)
Setpoint specification*	Within selected range
Neutral zone*	Max. 50 % of selected range
Proportional action*	Controller gain Kp: 0010 ... 9999 %
Integral action*	Reset time Tr: 0000 ... 9999 s (0000 s = no integral action)
Derivative action*	Rate time Td: 0000 ... 9999 s (0000 s = no derivative action)
Controller type*	Pulse length controller or pulse frequency controller
Pulse period*	0001 ... 0600 s, min. ON time 0.5 s (pulse length controller)
Max. pulse frequency*	0001 ... 0180 min ⁻¹ (pulse frequency controller)
Real-time clock	Different time and date formats selectable
Power reserve	> 5 days
Display	LC display, 7-segment with icons
Main display	Character height approx. 22 mm, unit symbols approx. 14 mm
Secondary display	Character height approx. 10 mm
Text line	14 characters, 14 segments
Sensoface	3 status indicators (friendly, neutral, sad face)
Mode indicators	meas, cal, conf, diag Further icons for configuration and messages
Alarm indication	Display blinks, red backlighting
Keypad	Keys: meas, info, 4 cursor keys, enter
HART communication	HART version 6 Digital communication by FSK modulation of output current 1 Device identification, measured values, status and messages, parameter setting, calibration, records
Conditions	Output current ≥ 3.8 mA and load resistance $\geq 250 \Omega$

Specifications

IrDA interface	Infrared interface for firmware update
FDA 21 CFR Part 11	Access control by editable passcodes Logbook entry and flag via HART in the case of configuration changes Message and logbook entry when enclosure is opened
Diagnostics functions	
Calibration data	Calibration date, cell factor, zero point
Device self-test	Displaytest, automatic memory test (RAM, FLASH, EEPROM), module test
Logbook	100 events with date and time
Extended logbook (TAN)	Audit Trail: 200 events with date and time
Service functions	
Sensor monitor	Display of direct sensor signals
Current source	Current specifiable for output 1 and 2 (00.00 ... 22,00 mA)
Relay test	Manual control of the four switching contacts
Manual controller	Controller output entered directly (start of control process)
IrDA	Activating the IrDA function
Passcodes	Assigning passcodes for menu access
Factory setting	Resetting all parameters to factory setting
TAN	Enabling optionally available additional functions
Data retention	Parameters, calibration data, logbook > 10 years (EEPROM)
EMC	EN 61326-1 (General Requirements)
Emitted interference	Class B (residential area)
Immunity to interference	Industry EN 61326-2-3
Explosion protection Stratos Pro A4...B CONDI (pending)	USA: FM Cl I Div 2 / Zone 2 Canada: CSA Cl I Div 2 / Zone 2

Power supply	24 (-15%) ... 230 (+10%) V AC/DC ¹⁾ ; < 12 VA, < 4 W AC: 45 ... 65 Hz Overvoltage category II, protection class II
Nominal operating conditions	
Ambient temperature	-20 ... +55 °C
Transport/Storage temperature	-20 ... +70 °C
Relative humidity	10 ... 95% not condensing
Power supply	24 (-15%) ... 230 (+10%) V AC/DC (DC ≤ 80V)
Frequency for AC	45 ... 65 Hz
Enclosure	Molded enclosure made of PBT/PC, glass reinforced
Fastening	Wall, pipe/post, or panel mounting
Color	Gray, RAL 7001
Ingress protection	IP 67
Flammability	UL 94 V-0
Dimensions	148 mm x 148 mm
Control panel cutout	138 mm x 138 mm to DIN 43 700
Weight	Approx. 1200 g
Cable glands	3 knockouts for M20 x 1.5 cable glands 2 knockouts for NPT ½" or rigid metallic conduit
Connections	Terminals, conductor cross section max. 2.5 mm ²

* User-defined

2) ± 1 count

4) DC ≤ 80 V

1) Acc. to EN 60746, at nominal operating conditions

3) Plus sensor error

Calibration Solutions

Potassium Chloride Solutions

(Conductivity in mS/cm)

Temperature [°C]	Concentration ¹		
	0.01 mol/l	0.1 mol/l	1 mol/l
0	0.776	7.15	65.41
5	0.896	8.22	74.14
10	1.020	9.33	83.19
15	1.147	10.48	92.52
16	1.173	10.72	94.41
17	1.199	10.95	96.31
18	1.225	11.19	98.22
19	1.251	11.43	100.14
20	1.278	11.67	102.07
21	1.305	11.91	104.00
22	1.332	12.15	105.94
23	1.359	12.39	107.89
24	1.386	12.64	109.84
25	1.413	12.88	111.80
26	1.441	13.13	113.77
27	1.468	13.37	115.74
28	1.496	13.62	
29	1.524	13.87	
30	1.552	14.12	
31	1.581	14.37	
32	1.609	14.62	
33	1.638	14.88	
34	1.667	15.13	
35	1.696	15.39	
36		15.64	

¹ Data source: K. H. Hellwege (Editor), H. Landolt, R. Börnstein: Zahlenwerte und Funktionen ..., volume 2, part. volume 6

Sodium Chloride Solutions

(Conductivity in mS/cm)

Temperature [°C]	Concentration		
	0.01 mol/l ¹⁾	0,1 mol/l ¹⁾	Saturated ²⁾
0	0.631	5.786	134.5
1	0.651	5.965	138.6
2	0.671	6.145	142.7
3	0.692	6.327	146.9
4	0.712	6.510	151.2
5	0.733	6.695	155.5
6	0.754	6.881	159.9
7	0.775	7.068	164.3
8	0.796	7.257	168.8
9	0.818	7.447	173.4
10	0.839	7.638	177.9
11	0.861	7.831	182.6
12	0.883	8.025	187.2
13	0.905	8.221	191.9
14	0.927	8.418	196.7
15	0.950	8.617	201.5
16	0.972	8.816	206.3
17	0.995	9.018	211.2
18	1.018	9.221	216.1
19	1.041	9.425	221.0
20	1.064	9.631	226.0
21	1.087	9.838	231.0
22	1.111	10.047	236.1
23	1.135	10.258	241.1
24	1.159	10.469	246.2
25	1.183	10.683	251.3
26	1.207	10.898	256.5
27	1.232	11.114	261.6
28	1.256	11.332	266.9
29	1.281	11.552	272.1
30	1.306	11.773	277.4
31	1.331	11.995	282.7
32	1.357	12.220	288.0
33	1.382	12.445	293.3
34	1.408	12.673	298.7
35	1.434	12.902	304.1
36	1.460	13.132	309.5

1 Data source: Test solutions calculated according to DIN IEC 746-3

2 Data source: K. H. Hellwege (Editor), H. Landolt, R. Börnstein: Zahlenwerte und Funktionen ..., volume 2, part. volume 6

Concentration Measurement

Ranges

Substance	Concentration ranges		
NaCl Configuration	0-26% by wt (0°C) 0-26% by wt (100°C) -01-		
HCl Configuration	0-18% by wt (-20 °C) 0-18% by wt (50 °C) -02-	22-39% by wt (-20 °C) 22-39% by wt (50°C) -07-	
NaOH Configuration	0-13% by wt (0 °C) 0-24% by wt (100 °C) -03-	15-50% by wt (0 °C) 35-50% by wt (100°C) -10-	
H ₂ SO ₄ Configuration	0-26% by wt (-17 °C) 0-37% by wt (110 °C) -04-	28-77% by wt (-17°C) 39-88% by wt (115°C) -09-	94-99% by wt (-17°C) 89-99% by wt (115°C) -06-
HNO ₃ Configuration	0-30% by wt (-20°C) 0-30% by wt (50°C) -05-	35-96% by wt (-20°C) 35-96% by wt (50°C) -08-	

For the solutions listed above, the device can determine the substance concentration from the measured conductivity and temperature values in % by wt. The measurement error is made up of the sum of measurements errors during conductivity and temperature measurement and the accuracy of the concentration curves stored in the device. We recommend to calibrate the device together with the sensor, e.g. directly to concentration using the CAL_CELL method. For exact temperature measurement, you should perform a temperature probe adjustment. For measuring processes with rapid temperature changes, a separate temperature probe with fast response should be used.

When measuring processes such as dilution or intensification of CIP solutions (Clean-In-Place), it is helpful to switch between the parameter sets for measuring the process medium and for measuring the CIP solution.

Concentration Curves

-01- Sodium chloride solution NaCl

← -01- →

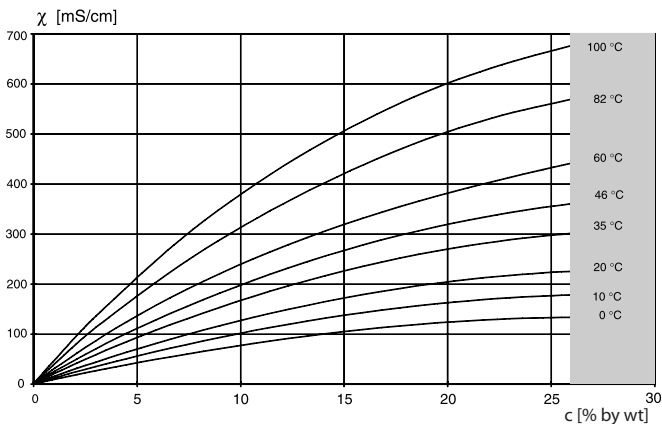

■ Concentration measurement not possible in this range.

Conductivity versus substance concentration and process temperature for sodium chloride solution (NaCl)

Concentration Curves

-02- Hydrochloric acid HCl

-07-

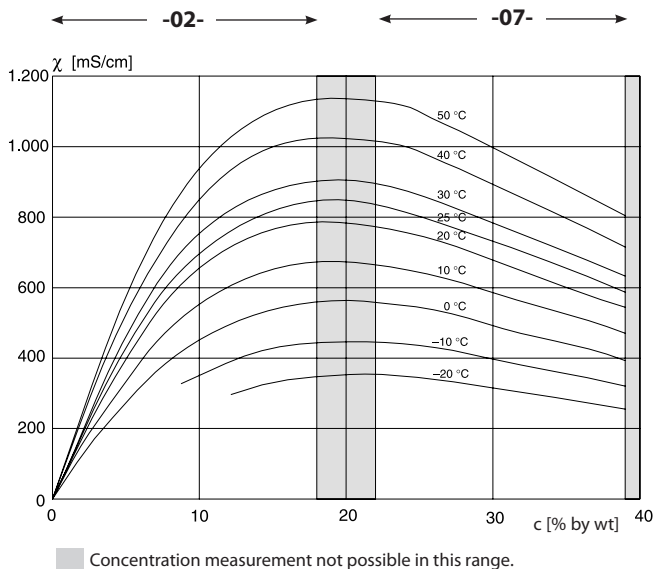

Conductivity versus substance concentration and process temperature for hydrochloric acid (HCl)

Source: Haase/Sauermann/Dücker; Z. phys. Chem. New Edition, Vol. 47 (1965)

-03- Sodium hydroxide solution NaOH

-10-

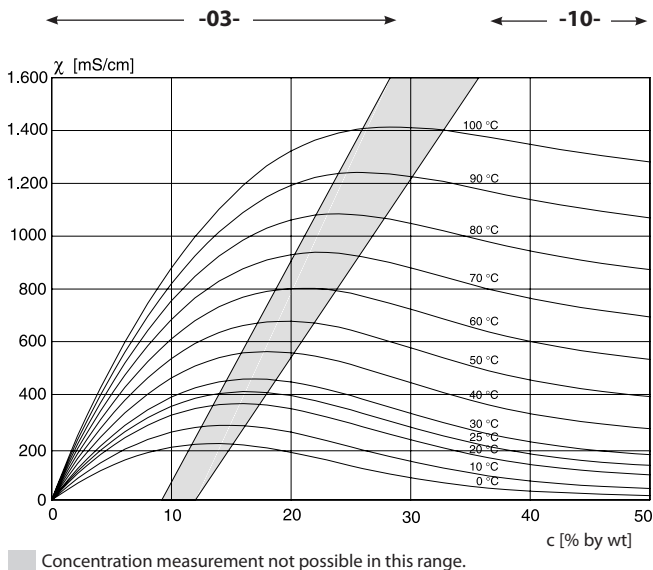

Conductivity versus substance concentration and process temperature for sodium hydroxide solution (NaOH)

Concentration Curves

-04- Sulfuric acid H_2SO_4

-06-

-09-

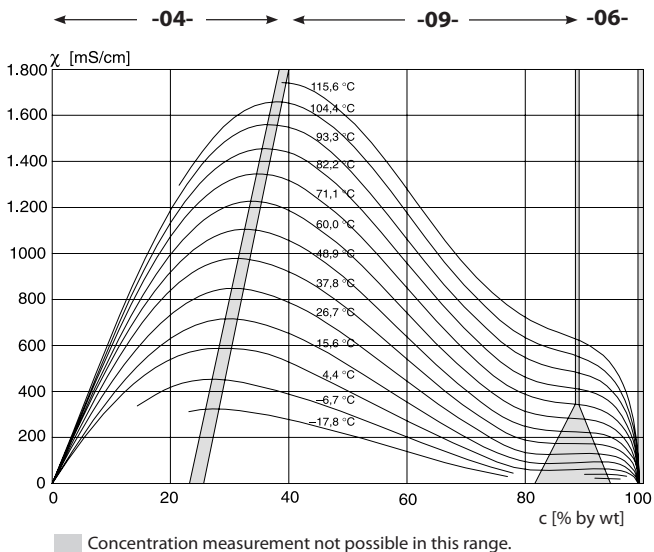

Conductivity versus substance concentration and process temperature for sulfuric acid (H_2SO_4)

Source: Darling; Journal of Chemical and Engineering Data; Vol.9 No.3, July 1964

-05- Nitric acid HNO_3

-08-

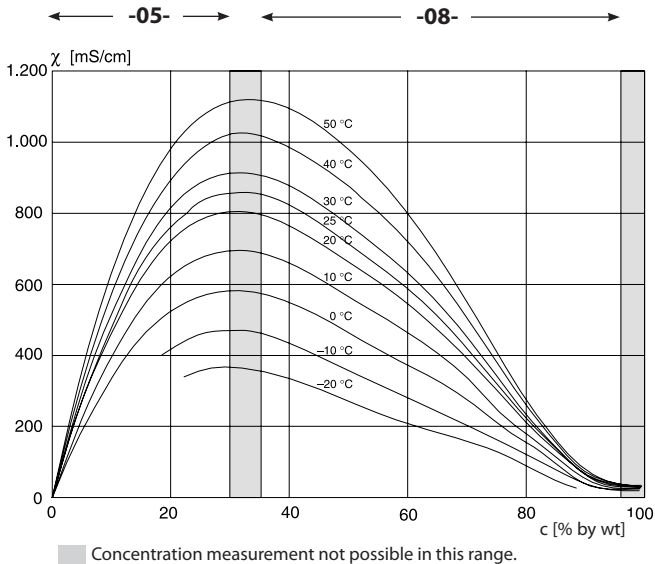

Conductivity versus substance concentration and process temperature for nitric acid (HNO_3)

Source: Haase/Sauermann/Dücker; Z. phys. Chem. New Edition, Vol. 47 (1965)

Alarm condition:

- The display backlighting turns **red**
- The alarm icon  is displayed
- The complete measured-value display blinks
- “**ERR xxx**” is displayed in the lower menu line

Press the [**info**] key to view a short error text:

- The error text appears in the lower menu line
- The main display reads “**InFo**”.

Parameter errors:

Configuration data such as current range, limit values, etc are checked during the input.

If they are out of range,

- “**ERR xxx**” is displayed for 3 sec,
- the display backlighting flashes red,
- the respective maximum or minimum value is shown,
- input must be repeated.

If a faulty parameter arrives through the interface (IrDA, HART),

- an error message will be displayed: “**ERR 100...199**”
- the faulty parameter can be localized by pressing the [**info**] key

Calibration errors:

If errors occur during calibration,

- an error message will be displayed
- calibration will be restarted

Sensoface:

If the Sensoface becomes sad,

- the display backlighting will turn purple
- the cause can be seen by pressing the **info** key
- the calibration data can be seen in the Diagnostics menu

Error Messages

Error	Info text (is displayed in case of fault when the Info key is pressed)	Problem Possible causes
ERR 99	DEVICE FAILURE	Error in factory settings EEPROM or RAM defective This error message only occurs in the case of a total defect. The device must be repaired and recalibrated at the factory.
ERR 98	CONFIGURATION ERROR	Error in configuration or calibration data Memory error in device program Configuration or calibration data defective; completely reconfigure and recalibrate the device.
ERR 97	NO MODULE INSTALLED	No module Please have the module replaced in the factory.
ERR 96	WRONG MODULE	Wrong module Please have the module replaced in the factory.
ERR 95	SYSTEM ERROR	System error Restart required. If error still persists, send in the device for repair.
ERR 100	INVALID SPAN OUT1	Span Out1 configuration error
ERR 101	INVALID SPAN OUT2	Span Out2 configuration error
ERR 104	INVALID PARAMETER CONTROLLER	Controller configuration error
ERR 105	INVALID SPAN I-INPUT	I-Input configuration error

Error	Info text (is displayed in case of fault when the Info key is pressed)	Problem Possible causes
ERR 11	<p>CONDUCTIVITY RANGE</p> <p>CONCENTRATION RANGE</p> <p>SALINITY RANGE</p>	<p>Display range violation</p> <p>Cond > 1999 mS/cm > 99.99 S/m</p> <p>Conc > 99.9 %</p> <p>SAL > 45.0 ‰</p>
ERR 12	CONDUCTANCE TOO HIGH	<p>Measuring range of conductance exceeded</p> <p>> 3500 mS/cm</p>
ERR 13	TEMPERATURE RANGE	Temperature range violation
ERR 15	SENSOCHECK	Sensocheck
ERR 60	OUTPUT LOAD	Load error
ERR 61	OUTPUT 1 TOO LOW	Output current 1 < 0 (3.8) mA
ERR 62	OUTPUT 1 TOO HIGH	Output current 1 > 20.5 mA
ERR 63	OUTPUT 2 TOO LOW	Output current 2 < 0 (3.8) mA
ERR 64	OUTPUT 2 TOO HIGH	Output current 2 > 20.5 mA

Sensoface

(Sensochek must have been activated during configuration.)



The smiley in the display (Sensoface) alerts to sensor problems (defective sensor, defective cable, maintenance required). The



permitted calibration ranges and the conditions for a friendly, neutral, or sad Sensoface are summarized in the following



table. Additional icons refer to the error cause.

Sensochek

Continuously monitors the sensor and leads for short circuits or open circuits. Critical values make the Sensoface “sad” and the corresponding icon blinks:



The Sensochek message is also output as error message Err 15.

The alarm contact is active, the display backlighting turns red, output current 1 is set to 22 mA (when configured correspondingly).





Sensochek can be switched off during configuration (then Sensoface is also disabled).

Exception:

After a calibration a smiley is always displayed for confirmation.

Please note:

The worsening of a Sensoface criterion leads to the devaluation of the Sensoface indicator (Smiley becomes “sad”). An improvement of the Sensoface indicator can only take place after calibration or removal of the sensor defect.

Display	Problem	Status	
	Sensor defect		Wrong or defective sensor or excessive cable capacitance (see also error message Err 15).
	Temperature		Temperature outside range for TC, conc, sal

FDA 21 CFR Part 11

Conformity with FDA 21 CFR Part 11

In their directive “Title 21 Code of Federal Regulations, 21 CFR Part 11, Electronic Records; Electronic Signatures” the US American health agency FDA (Food and Drug Administration) regulates the production and processing of electronic documents for pharmaceutical development and production. This results in requirements for measuring devices used for corresponding applications. The following features ensure that the measuring devices of this Series meet the demands of FDA 21 CFR Part 11:

Electronic Signature – Passcodes

Access to the device functions is regulated and limited by individually adjustable codes – “Passcodes” (see SERVICE). This prevents unauthorized modification of device settings or manipulation of the measurement results. Appropriate use of these passcodes makes them suitable as electronic signature.

Audit Trail

Every (manual) change of device settings can be automatically documented. Each change is tagged with a “Configuration Change Flag”, which can be interrogated and documented using HART communication. Altered device settings or parameters can also be retrieved and documented using HART communication.

Extended logbook

Audit Trail also records function activations (CAL, CONFIG, SERVICE), some Sensoface messages (cal timer, wear), and opening of the enclosure.

A

- Access codes **132, 144**
- Accessories **110**
- Alarm **35**
- Alarm settings **66**
 - Alarm contact **67**
- Ambulance TAN **106**
- Application in hazardous locations **15**
- Approvals for application in hazardous locations **9, 116**
- Assembly **11**
- Audit Trail **132**
- Autorange **55**

B

- Backlighting **29**

C

- Cable preparation SE 655 / SE 656 **19**
- Calibration **32, 87**
 - Calibration error **127**
- Calibration by entry of cell factor **90**
- Calibration data **99**
- Calibration error **127**
- Calibration mode **87**
- Calibration solutions **118**
- Calibration with calibration solution **88**
- CD-ROM **3**
- CIP / SIP **53**
- Compulsory marking **9, 16**
- Concentration curves
 - 01- Sodium chloride solution NaCl **121**
 - 02- Hydrochloric acid HCl **122**
 - 03- Sodium hydroxide solution NaOH **123**
 - 04- Sulfuric acid H₂SO₄ **124**
 - 05- Nitric acid HNO₃ **125**

Concentration measurement 50, 120

 Ranges 120

Configuration 32

 Alarm settings 66

 Controller 78

 Current output 1 54

 Current output 2 60

 Individual configuration data 44

 Limit function 68

 Menu groups 37

 Menu structure 36

 Sensor 48

 Tag number 84

 Temperature compensation 62

 Time and date 84

 WASH contact 82

Controller 75

 Configuration 78

 Controller equations 76

 Controller functions 75

 Controller test 105

 Controller type 79

 Manual specification of controller output 105

 Neutral zone 81

 Pulse frequency 79

 Pulse length 79

 Setpoint 79

Controller characteristic 75

Current start / end 55

D

Date 85

 Display 95

Device self-test 100

Device type, display 102

- Diagnostics **32, 98**
 - Calibration data **99**
 - Device self-test **100**
 - Logbook **101**
 - Sensor monitor **101**
 - Version **102**
- Dimensions **12**
- Display **29**
 - Display data in Diagnostics mode **98**
 - Display test **100**
- Display backlighting **29**
- Disposal **2**
- Documentation **3**

E

- EEPROM test **100**
- Electrical installation **9**
- Electronic Signature **132**
- Enclosure **12**
- Enclosure components **11**
- Entering values **31**
- Error handling **127**
- Error messages **128**
- Explosion protection **116**
- Extended logbook **132**

F

- FDA 21 CFR Part 11 **132**
- FLASH test **100**

H

- HOLD **32, 34**
 - End **34**
 - External activation of HOLD **35**
 - Manual activation of HOLD **35**
 - Output signal during HOLD **34, 59**
- Hysteresis **71, 73**

I

- Info text 128
- Installation 15
 - Safety information 9
- Installation instructions 15
- Intended use 7
- IrDA communication 105

K

- Keypad 28

L

- Limit function 68
- Logbook 101

M

- Measurement 95
- Measuring 30
- Measuring mode selection 48
- Menu structure 33
 - Configuration 36
- Module test 100
- Mounting plan 12

O

- Operating modes 32
- Operating mode, selection 31
- Operating states 108
- Option request: Conditions 102
- Options 106, 110
- Order code 110
- Output current, fixed value 104
- Output filter 56
- Output signal during HOLD 34, 59
- Overview 10

P

- Package contents **3, 11**
- Panel mounting **14**
- Parameter error **127**
- Parameter set A/B **37**
 - Display **95**
 - Display via WASH contact **38**
 - Manual selection **38**
- Passcodes **132, 144**
 - Setting **106**
- PFC **77**
- Pipe mounting **13**
- PLC **77**
- Point of measurement (TAG) **85**
- Power supply **17**
- Product calibration **91**
- Product line **110**
- Protective hood **13**
- Protective wiring **26**
- Pulse frequency controller (PFC) **77**
- Pulse length controller (PLC) **77**

R

- RAM test **100**
- Rating plates **16**
- Registered trademarks **143**
- Relay 1 **68**
- Relay 2 **72**
- Relay test **104**
- Release of options **106**
- Reset to factory settings **106**
- Return of products under warranty **2**

S

- Safety information 7, 8
- Safety instructions 3
- SE 670 sensor: Connection via RS-485 25
- Selection menu 31
- Select temperature probe 48
- Sensocheck 66, 130
- Sensoface 127, 130
- Sensor connection 18, 20
- Sensor monitor 101, 104
- Sensor type selection 48
- Serial number, display 102
- Service 32, 103
 - Controller test 105
 - Factory setting 106
 - IrDA communication 105
 - Passcodes 106
 - Relay test 104
 - Releasing options 106
 - Sensor monitor 104
 - Specifying current outputs 104
- Service passcode lost 106
- Signal colors 29
- Signal lines 17
- Software version, display 102
- Specifications 111
- Start-up 8

T

- TAG 85
- TAN options 106, 110
- Temperature compensation 63
- Temperature probe 94
- Temperature unit 50
- Terminal assignments 16
- Terminals 9, 15

Time **85**
 Display **95**
Time averaging filter **57**
Trademarks **143**

U

User interface **28**

W

Warranty **2**
WASH contact
 Configuration **82**
 Signaling parameter set **38**
Wiring **17**
 Sensor connection **18**
Wiring examples
 SE 655 / SE 656 **20**
 SE 660 **21**
 SE 670 (via RS-485) **24**
 Yokogawa IC 40S **23**
 Yokogawa ISC 40 **22**

Z

Zero calibration **93**

Trademarks

The following names are registered trademarks. For practical reasons they are shown without trademark symbol in this manual.

Stratos®

Sensocheck®

Sensoface®

Calimatic®

GainCheck®

InPro® is a registered trademark of Mettler-Toledo.

Memosens® is a registered trademark of Endress+Hauser Conducta GmbH and Knick Elektronische Messgeräte GmbH & Co. KG.

HART® is a registered trademark of the HART Communication Foundation.

Passcodes

In the SERVICE – CODES menu you can assign passcodes to protect the access to certain functions.

Operating mode	Passcode
Service (SERVICE)	5555
Diagnostics (DIAG)	
HOLD mode	
Calibration (CAL)	
Configuration (CONF)	

Knick Elektronische Messgeräte GmbH & Co. KG

P.O. Box 37 04 15
D-14134 Berlin

Tel: +49 (0)30 - 801 91 - 0
Fax: +49 (0)30 - 801 91 - 200
Internet: <http://www.knick.de>
knick@knick.de