

# Stratos® Pro A4... MSCOND

## Instruction Manual

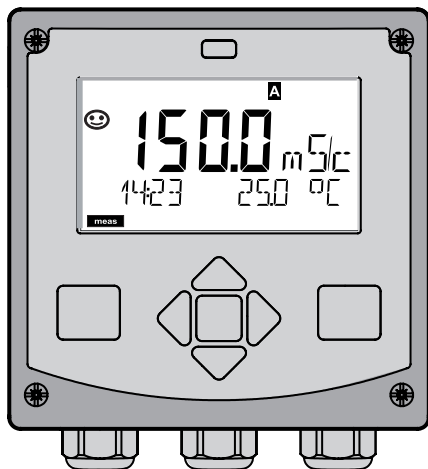

---

Latest Product Information:

[www.knick.de](http://www.knick.de)

---



77452

**Knick** >

# Warranty

---

## **Warranty**

Defects occurring within 3 years from delivery date shall be remedied free of charge at our plant (carriage and insurance paid by sender).  
Sensors, fittings, and accessories: 1 year.

Subject to change without notice.

## **Return of Products Under Warranty**

Please contact our Service Team before returning a defective device. Ship the cleaned device to the address you have been given. If the device has been in contact with process fluids, it must be decontaminated/disinfected before shipment. In that case, please attach a corresponding certificate, for the health and safety of our service personnel.

## **Disposal**

Please observe the applicable local or national regulations concerning the disposal of “waste electrical and electronic equipment”.



## CD-ROM

Complete documentation:

- Instruction manuals
- Safety instructions
- Short instructions



## Safety Information

In official EU languages and others.

- ATEX / IECEX / FM / CSA
- EC Declarations of Conformity

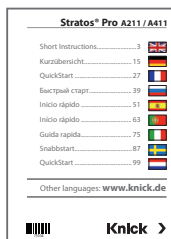

## Short Instructions

In German, English, French, Russian, Spanish, Portuguese, Swedish, and Dutch. More languages on CD-ROM and on our website: [www.knick.de](http://www.knick.de)

- Installation and commissioning
- Operation
- Menu structure
- Calibration
- Error messages and recommended actions

## Specific Test Report

# Contents

---

<b>Documents Supplied .....</b>	<b>3</b>
<b>Introduction .....</b>	<b>7</b>
Intended Use .....	7
<b>Safety Information .....</b>	<b>8</b>
Safety Precautions for Installation.....	9
<b>Overview of Stratos Pro A4... MSCOND.....</b>	<b>10</b>
<b>Assembly .....</b>	<b>11</b>
Package Contents .....	11
Mounting Plan, Dimensions .....	12
Pipe Mounting, Protective Hood.....	13
Panel Mounting .....	14
<b>Installation .....</b>	<b>15</b>
Installation Instructions.....	15
Rating Plates / Terminal Assignments .....	16
Power Supply, Signal Lines.....	17
Connection of Memosens Sensor.....	19
Protective Wiring of Relay Contacts.....	20
<b>User Interface, Keypad .....</b>	<b>22</b>
Display.....	23
Signal Colors (Display Backlighting) .....	23
Measuring Mode .....	24
Selecting the Mode / Entering Values.....	25
Operating Modes .....	26
Menu Structure of Modes and Functions .....	27
HOLD Mode .....	28
Alarm .....	29
<b>Configuration .....</b>	<b>30</b>
Menu Structure of Configuration.....	30
Parameter Set A/B.....	32

<b>Configuration (Original for Copy)</b> .....	<b>38</b>
Sensor.....	42
Current Output 1 .....	48
Current Output 2.....	54
Temperature Compensation.....	56
Alarm Settings.....	60
Limit Function .....	62
Pulse Length / Pulse Frequency Controller .....	71
Controller .....	72
WASH Contact.....	76
Time and Date.....	78
Tag Number .....	78
<b>Digital Sensors</b> .....	<b>80</b>
Operation.....	80
Connecting a Digital Sensor .....	81
Sensor Replacement.....	82
<b>Calibration</b> .....	<b>85</b>
Selecting a Calibration Mode .....	85
Calibration with Calibration Solution.....	86
Calibration by Entry of Cell Constant .....	88
Product Calibration .....	89
Temp Probe Adjustment .....	91
<b>Measurement</b> .....	<b>92</b>
<b>Diagnostics</b> .....	<b>95</b>
<b>Service</b> .....	<b>100</b>
<b>USP Function</b> .....	<b>104</b>
<b>Operating States</b> .....	<b>106</b>
<b>Product Line and Accessories</b> .....	<b>108</b>
<b>Specifications</b> .....	<b>109</b>
<b>Calibration Solutions</b> .....	<b>116</b>

# Contents

---

Concentration Curves .....	118
Error Handling.....	123
Error Messages.....	124
Sensoface .....	126
FDA 21 CFR Part 11 .....	128
Electronic Signature – Passcodes.....	128
Audit Trail.....	128
Index .....	129
Trademarks.....	139
Passcodes .....	140

## Intended Use

Stratos Pro A4... MSCOND is used for measurement of electrical conductivity and temperature in liquids. Fields of application are: biotechnology, chemical industry, environment, food processing, water/waste-water treatment.

The sturdy molded enclosure can be fixed into a control panel or mounted on a wall or at a post. The protective hood, which is available as accessory, provides additional protection against direct weather exposure and mechanical damage.

The device has been designed for Memosens sensors.

Plain-text messages in a large, backlit display allow intuitive operation. The colored display backlighting signals alarm messages (red) or HOLD mode (orange).

The "Sensocheck" automatic monitoring of sensor and cables and the "Sensoface" function for clear indication of the sensor condition provide excellent diagnostics.

The internal logbook (TAN SW-A002) can handle up to 100 entries – up to 200 with AuditTrail (TAN SW-A003).

The device provides two parameter sets which can be switched manually or via a control input for different process adaptations or different process conditions (e.g. beer and CIP).

Password protection for granting access rights during operation can be configured.

Two floating, digital control inputs ("Hold" and "Control") are available for external control.

The internal PID process controller can be configured as pulse length or pulse frequency controller.

The device provides two current outputs (for transmission of measured value and temperature, for example) and four floating relay contacts. A time-controlled cleaning function can be configured.

Current is provided through a universal power supply 24 ... 230 V AC/DC, AC: 45 ... 65 Hz.

## Approvals for Measurement in Hazardous Locations:

Stratos Pro A4...B MSCOND: acc. to FM and CSA in Class I Div 2 / Zone 2

# Safety Information

---

## Safety information –

### **Be sure to read and observe the following instructions!**

The device has been manufactured using state of the art technology and it complies with applicable safety regulations.

When operating the device, certain conditions may nevertheless lead to danger for the operator or damage to the device.

See also separate document:

- “Safety Instructions”.  
(EC Declaration of Conformity, FM, CSA Certificates)



## **CAUTION!**

Commissioning must only be performed by trained personnel authorized by the operating company! Whenever it is likely that protection has been impaired, the device shall be made inoperative and secured against unintended operation.

The protection is likely to be impaired if, for example:

- the device shows visible damage
- the device fails to perform the intended measurements
- after prolonged storage at temperatures above 70°C
- after severe transport stresses

Before recommissioning the device, a professional routine test must be performed. This test must be carried out at the manufacturer's factory.

### **Please note:**

Before commissioning it must be proved that the device may be connected with other equipment.

## Safety Precautions for Installation

- The electrical installation shall conform to the national regulations for electrical installations and/or other applicable national or local codes or regulations.
- The power supply shall be disconnectable from the device by a two-poled circuit breaker.
- Switch and circuit breaker shall be located in close proximity to the equipment and be easily accessible by the OPERATOR. They shall be marked as disconnect switch for the device.
- Be sure to disconnect the mains supply and any relay contacts which are connected to separate current sources before starting maintenance operations.

## Approvals for application in hazardous locations

Stratos Pro A4...B MSCOND: acc. to FM and CSA in Class I Div 2 / Zone 2 (pending). See also separate "Safety Instructions" document.

### Terminals:

Screw terminal, suitable for single wires / flexible leads up to 2.5 mm<sup>2</sup> (AWG 14).

Recommended torque for the terminal screws: 0.5 ... 0.6 Nm.



### Important Notice:

**The operator must indicate the type of protection!**

When the device provides different types of protection, the operator must specify the applied type of protection during installation.

To do so, use the checkboxes on the rating plate:

<b>Knick</b> >	YY <input checked="" type="checkbox"/>	SA,08.2117513	<input type="checkbox"/> FM xxxxxxxx	
A ...	<input type="checkbox"/>	IS CII, Div 1, GRP A,B,C,D,E,F,G T4	<input type="checkbox"/>	AIS/IS/I, II, III/1/ABCDEFGHI/T4
No. 12345 / 1234567 / 0845	<input type="checkbox"/>	AIS CI I, II, III, Div 1, GRP A,B,C,D,E,F,G T4	<input type="checkbox"/>	NI/II, III/2/ABCDEFGHI/T4
-20 ≤ T <sub>a</sub> ≤ +65 °C	<input type="checkbox"/>	CI I, Zone 1, AEx ia IIC T4	<input type="checkbox"/>	I/1/AEx ia IIC T4
D-14163 Berlin Made in Germany	<input type="checkbox"/>	Control drawing 212,002-330	<input type="checkbox"/>	I/2/AEx nA IIC T4
	<input type="checkbox"/>		<input type="checkbox"/>	Control drawing 212,002-300

Additional rating plate at outside bottom of front with checkboxes for marking the respective application after installation

# Overview

## Overview of Stratos Pro A4... MSCOND

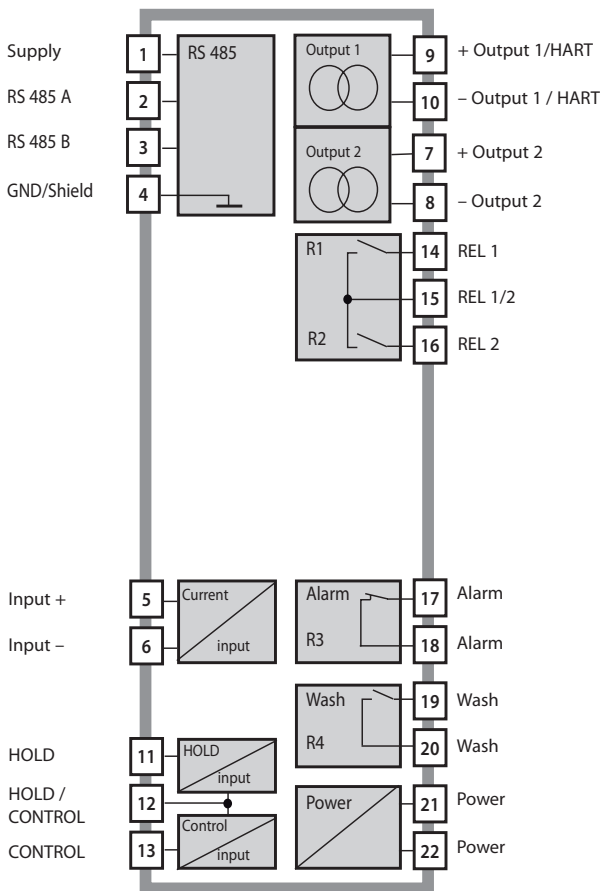

## Package Contents

Check the shipment for transport damage and completeness!

### The package should contain:

- Front unit, rear unit, bag containing small parts
- Specific test report
- Documentation (cf Pg 3)
- CD-ROM

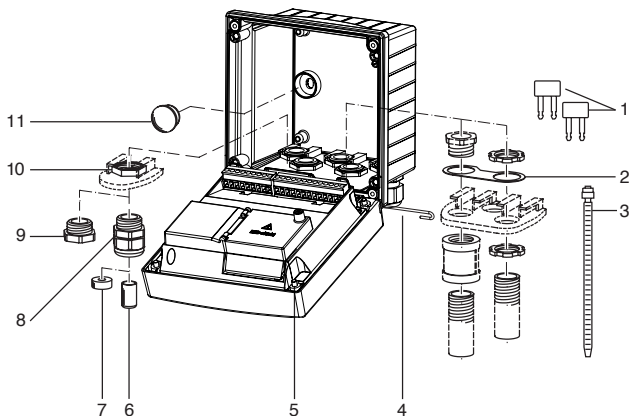

Fig.: Assembling the enclosure

- |   |  |
|---|--|
| 1) Jumper (3 x)   | 6) Sealing insert (1 x)                                      |
| 2) Washer (1 x), for conduit mounting: Place washer between enclosure and nut | 7) Rubber reducer (1 x)                                      |
| 3) Cable tie (3 x)  | 8) Cable gland (3 x)   |
| 4) Hinge pin (1 x), insertable from either side                               | 9) Filler plug (3 x)   |
| 5) Enclosure screw (4 x)  | 10) Hexagon nut (5 x)  |
|   | 11) Sealing plug (2 x), for sealing in case of wall mounting |

## Mounting Plan, Dimensions

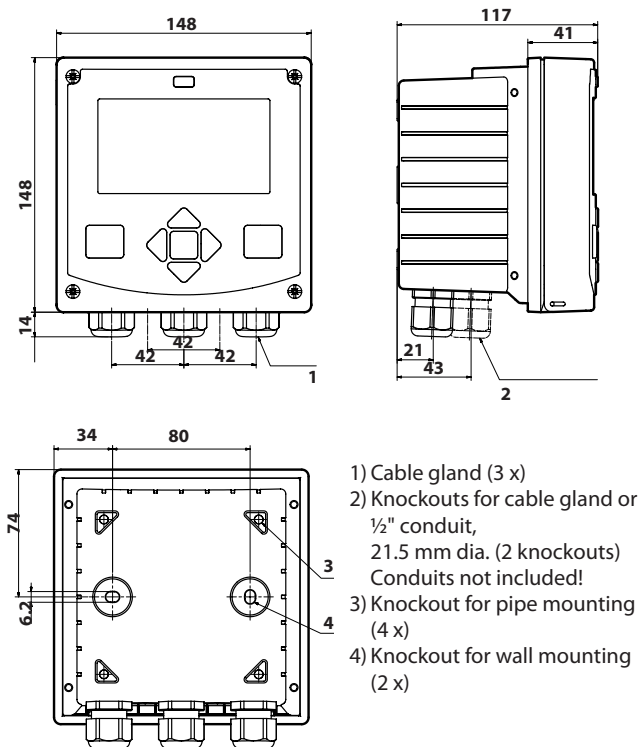
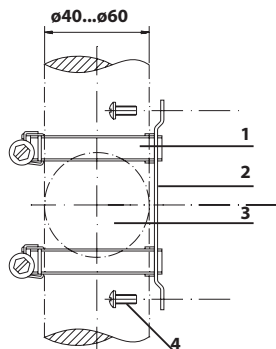

Fig.: Mounting plan (All dimensions in mm!)

## Pipe Mounting, Protective Hood



- 1) Hose clamp with worm gear drive to DIN 3017 (2 x)
- 2) Pipe-mount plate (1 x)
- 3) For vertical or horizontal posts or pipes
- 4) Self-tapping screw (4 x)

Fig.: ZU 0274 pipe-mount kit (All dimensions in mm!)

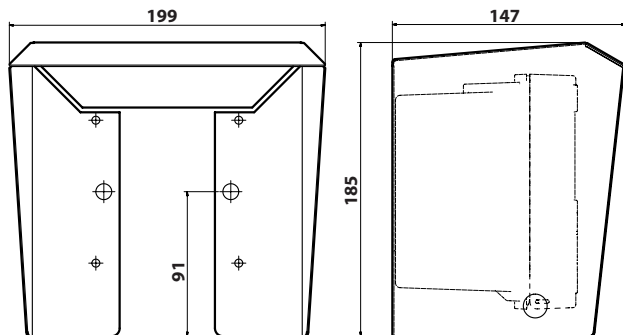

Fig.: ZU 0737 protective hood for wall and pipe mounting  
(All dimensions in mm!)

## Panel Mounting

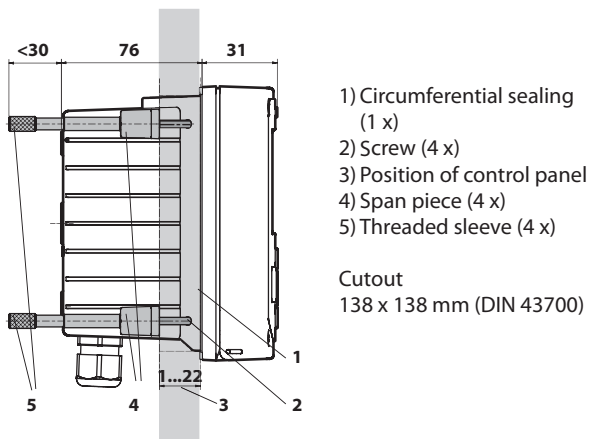

Fig.: ZU 0738 panel-mount kit (All dimensions in mm!)

## Installation Instructions

- Installation of the device must be carried out by trained experts in accordance with this instruction manual and as per applicable local and national codes.
- Be sure to observe the technical specifications and input ratings during installation!
- Be sure not to notch the conductor when stripping the insulation!
- Before connecting the device to the power supply, make sure that its voltage lies within the range 20.5 to 253 V AC/DC!
- The supplied current must be galvanically isolated.  
If not, connect an isolator module.
- All parameters must be set by a system administrator prior to commissioning!

## Terminals:

suitable for single wires / flexible leads up to 2.5 mm<sup>2</sup> (AWG 14)



Additional safety precautions have to be taken for operation in hazardous locations FM, CSA Cl. I Div 2 / Zone 2!  
(See separate “Safety Instructions” document.)

## Rating Plates / Terminal Assignments

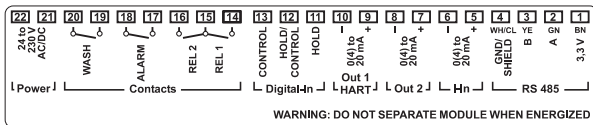

Fig.: Terminal assignments of Stratos Pro A4...

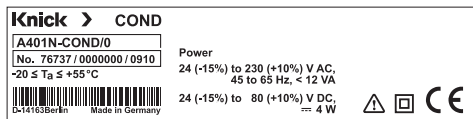

Fig.: Stratos Pro A401N-MSCOND rating plate at bottom of front

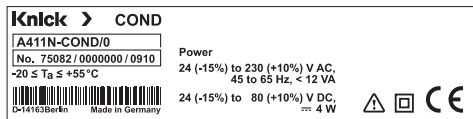

Fig.: Stratos Pro A411N-MSCOND rating plate at bottom of front

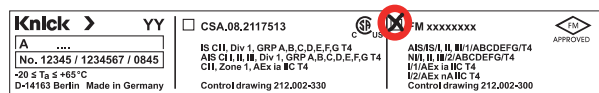

Fig.: Example of additional approval plate (cCSAus, FM)

The specifications refer to the respective device.

### Important Notice:

#### The operator must indicate the type of protection!

When the device provides different types of protection, the operator must specify the applied type of protection during installation.

# Power Supply, Signal Lines

Connect the power supply for Stratos Pro A401/A411 COND to terminals 21 and 22

(24 ... 230 V AC, 45 ... 65 Hz / 24 ... 80 V DC)

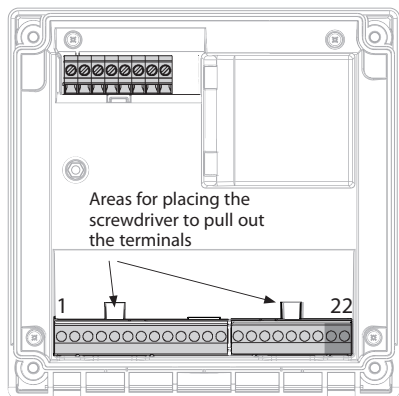

## Terminal assignments

1	supply
2	RS 485 A
3	RS 485 B
4	GND/shield
5	+ input
6	- input
7	+ out 2
8	- out 2
9	+ out 1/HART
10	- out 1/HART
11	hold
12	hold/control
13	control
14	REL 1
15	REL 1/2
16	REL 2
17	alarm
18	alarm
19	wash
20	wash
21	power
22	power

Fig.: Terminals, device opened, back of front unit

## Wiring Example

---

Measuring task: Conductivity, temperature

Sensor: Memosens

Caution! Connection to RS-485 interface!

The measuring module slot must be empty\*!

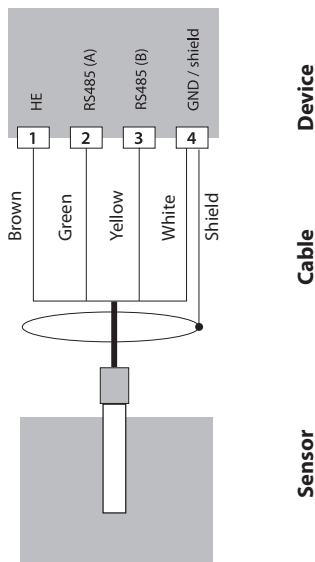

The Memosens sensor is connected to the RS-485 interface of the device. When the sensor is selected in the Configuration menu, the default values are taken as calibration data. They can then be modified by calibration.

\*)Stratos Pro A2... MSCOND is intended for connecting a Memosens sensor via RS-485 interface. It does not provide a measuring module.

## Connection of Memosens Sensor

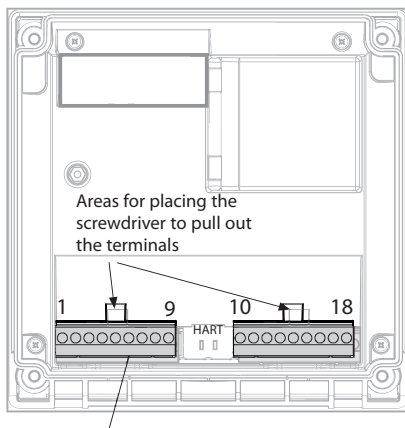

Memosens connection:		Wire color
1	Supply	Brown
2	RS 485 A	Green
3	RS 485 B	Yellow
4	GND/shield	White, transparent shield

# Protective Wiring of Relay Contacts

## Protective Wiring of Relay Contacts

Relay contacts are subject to electrical erosion. Especially with inductive and capacitive loads, the service life of the contacts will be reduced. For suppression of sparks and arcing, components such as RC combinations, nonlinear resistors, series resistors, and diodes should be used.

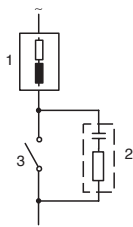
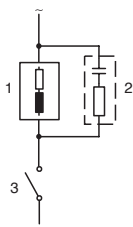

### Typical AC applications with inductive load

- 1 Load
- 2 RC combination, e.g. RIFA PMR 209  
Typical RC combinations for 230 V AC:  
capacitor 0.1  $\mu\text{F}$  / 630 V,  
resistor 100  $\Omega$  / 1 W
- 3 Contact

# Protective Wiring of Relay Contacts

## Typical Protective Wiring Measures

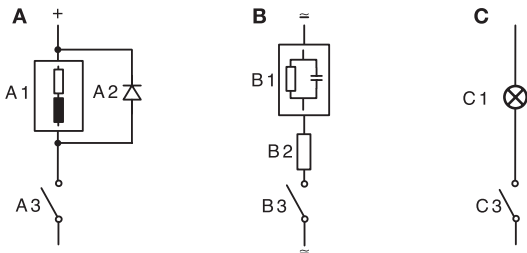

- A:** DC application with inductive load  
**B:** AC/DC applications with capacitive load  
**C:** Connection of incandescent lamps

- A1 Inductive load  
A2 Free-wheeling diode, e.g. 1N4007 (Observe polarity)  
A3 Contact  
B1 Capacitive load  
B2 Resistor, e.g.  $8\ \Omega$  / 1 W at 24 V / 0.3 A  
B3 Contact  
C1 Incandescent lamp, max 60 W / 230 V, 30 W / 115 V  
C3 Contact



### WARNING!

**Make sure that the maximum ratings of the relay contacts are not exceeded even during switching!**

# User Interface, Keypad

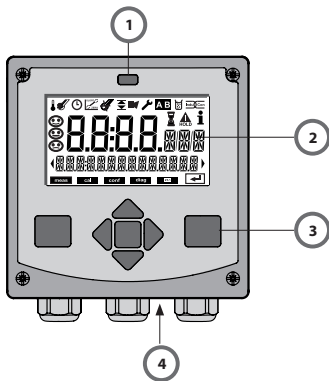

- 1 IrDA transmitter/receiver
- 2 Display
- 3 Keypad
- 4 Rating plate (bottom)

Key	Function
<b>meas</b>	<ul style="list-style-type: none"><li>• Return to last menu level</li><li>• Directly to measuring mode (press &gt; 2 s)</li></ul>
<b>info</b>	<ul style="list-style-type: none"><li>• Retrieve information</li><li>• Show error messages</li></ul>
<b>enter</b>	<ul style="list-style-type: none"><li>• Configuration: Confirm entries, next configuration step</li><li>• Calibration: Continue program flow</li><li>• Measuring mode: Display output current</li></ul>
<b>Arrow keys up / down</b>	<ul style="list-style-type: none"><li>• Measuring mode: Call menu</li><li>• Menu: Increase/decrease a numeral</li><li>• Menu: Select</li></ul>
<b>Arrow keys left / right</b>	<ul style="list-style-type: none"><li>• Measuring mode: Call menu</li><li>• Menu: Previous/next menu group</li><li>• Number entry: Move between digits</li></ul>

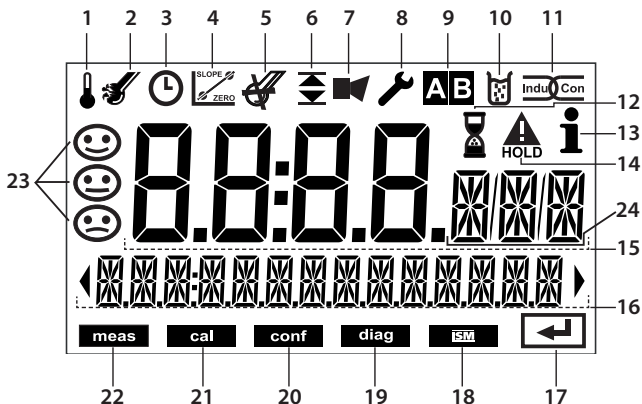

- |    |                        |    |                    |
|----|------------------------|----|--------------------|
| 1  | Temperature            | 13 | Info available     |
| 2  | Sensocheck             | 14 | HOLD mode active   |
| 3  | Interval/response time | 15 | Main display       |
| 4  | Sensor data            | 16 | Secondary display  |
| 5  | Not used               | 17 | Proceed with enter |
| 6  | Limit values           | 18 | Not used           |
| 7  | Alarm                  | 19 | Diagnostics        |
| 8  | Service                | 20 | Configuration mode |
| 9  | Parameter sets A/B     | 21 | Calibration mode   |
| 10 | Calibration            | 22 | Measuring mode     |
| 11 | Digital sensor         | 23 | Sensoface          |
| 12 | Waiting time running   | 24 | Measurement symbol |

## Signal Colors (Display Backlighting)

- |           |   |
|-----------|---|
| Red       | Alarm   |
| Orange    | HOLD mode (Calibration, Configuration, Service) |
| Turquoise | Diagnostics                                     |
| Green     | Info  |
| Purple    | Sensoface message                               |

# Measuring Mode

After the operating voltage has been connected and the sensor identified, the device automatically goes to "Measuring" mode. To call the measuring mode from another operating mode (e.g. Diagnostics, Service): Hold **meas** key depressed (> 2 s).

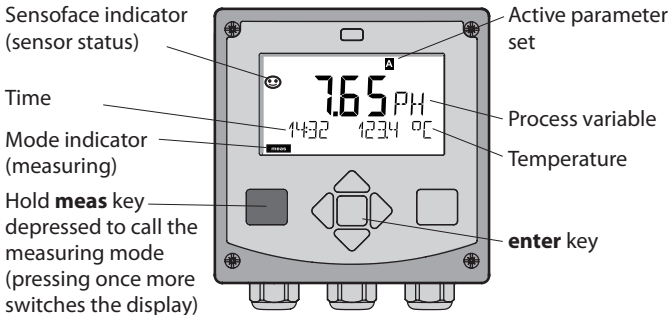

In measuring mode the display indicates:

- Measured value and time (24/12 h AM/PM) as well as temperature in °C or °F (formats selected during configuration)

By pressing the **meas** key in measuring mode you can view the following displays (for approx. 60 sec):

- Measured value and selection of parameter set A/B (if set to "Manual")
- Measured value and tag (point of measurement designation – entered during configuration)
- Time and date
- Controller (if configured), upper display: controller output Y, lower display: Setpoint

Pressing the **enter** key shows the output currents. They are displayed as long as **enter** is held depressed, then the measured-value display will return after 3 sec.

 The device must be configured for the respective measurement task!

# Selecting the Mode / Entering Values

## To select the operating mode:

- 1) Hold **meas** key depressed (> 2 s) (directly to measuring mode)
- 2) Press any arrow key: the selection menu appears
- 3) Select operating mode using left / right arrow key
- 4) Press **enter** to confirm the selected mode

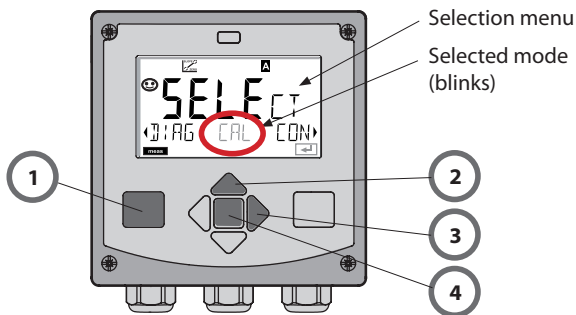

## To enter a value:

- 5) Select numeral: left / right arrow key
- 6) Change numeral: up / down arrow key
- 7) Confirm entry by pressing **enter**

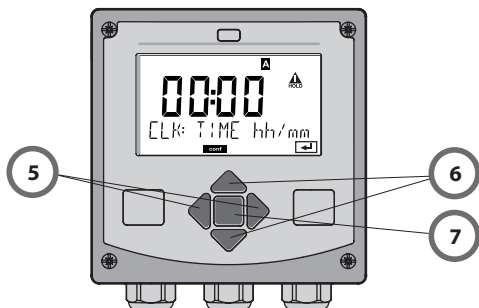

# Operating Modes

---

## **Diagnostics**

Display of calibration data, display of sensor data, performing a device self-test, viewing the logbook entries, display of hardware/software versions of the individual components. The logbook can store 100 events (00...99). They can be displayed directly on the device.

The logbook can be extended to 200 entries using a TAN (Option).

## **HOLD**

Manual activation of HOLD mode, e.g. for servicing. The signal outputs adopt a defined state.

## **Calibration**

Every sensor has typical characteristic values. Calibration is required to supply a correct measured value. The device checks which value the sensor delivers when measuring in a known solution. When there is a deviation, the device can be "adjusted". In that case, the device displays the "actual" value and internally corrects the measurement error of the sensor. During calibration the device is in HOLD mode.

**During calibration the analyzer remains in the HOLD mode until it is stopped by the operator.**

## **Configuration**

The analyzer must be configured for the respective measurement task. In the "Configuration" mode you select the connected sensor, the measuring range to be transmitted, and the conditions for warning and alarm messages. During configuration the device is in HOLD mode.

**Configuration mode is automatically exited 20 minutes after the last keystroke. The device returns to measuring mode.**

## **Service**

Maintenance functions (current source, relay test, controller test), IrDA operation, passcode assignment, reset to factory settings, enabling of options (TAN).

# Menu Structure of Modes and Functions



Pressing any arrow key opens the selection menu.  
Select the menu group using the left/right arrow keys.  
Press **enter** to open a menu. Press **meas** to return.

DIAG	CALDATA	Display of calibration data
	SENSOR	Display of sensor data
	SELFTEST	Self test: RAM, ROM, EEPROM, module
	LOGBOOK	Logbook: 100 events with date and time
	MONITOR	Display of direct, uncorrected sensor signals
	VERSION	Display of software version, model designation, serial number
HOLD	Manual activation of HOLD mode, e.g. for sensor replacement. The signal outputs behave as configured (e.g. last measured value, 21 mA)	
CAL	CAL_SOL	Calibration with calibration solution
	CAL_CELL	Calibration by entry of cell constant
	P_CAL	Product calibration
	CAL_RTD	Adjustment of temperature probe
CONF	PARSET A	Configuring parameter set A
	PARSET B	Configuring parameter set B
SERVICE (Access via code, factory setting: 5555)	MONITOR	Display of measured values for validation (simulators)
	OUT1	Current source, output 1
	OUT2	Current source, output 2
	RELAIS	Relay test
	CONTROL	Controller: manual specification of controller output
	IRDA	Activating the IrDA interface
	CODES	Specifying access codes for operating modes
	DEFAULT	Reset to factory setting
	OPTION	Enabling an option via TAN

# HOLD Mode

---

The HOLD mode is a safety state during configuration and calibration. Output current is frozen (Last) or set to a fixed value (Fix). Alarm and limit contacts are disabled. The HOLD mode is indicated by orange display backlighting.

**HOLD mode**, display icon:



## Output Signal Response

- **Last:** The output current is frozen at its last value. Recommended for short configuration procedures. The process should not change decisively during configuration. Changes are not noticed with this setting!
- **Fix:** The output current is set to a value that is noticeably different from the process value to signal the control system that the device is being worked at.

## Output Signal During HOLD:

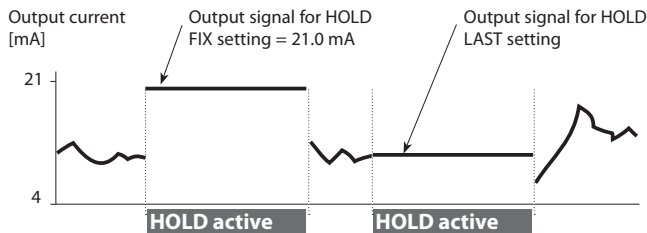

## Terminating the HOLD Mode

The HOLD mode is ended by switching to measuring mode (hold **meas** key depressed). The display reads "Good Bye", after that, the HOLD mode is exited.

When the calibration mode is exited, a confirmation prompt ensures that the installation is ready for operation (e.g.: sensor reinstalled, located in process).

## External Activation of HOLD

The HOLD mode can be activated from outside by sending a signal to the Hold input (e.g. from the process control system).

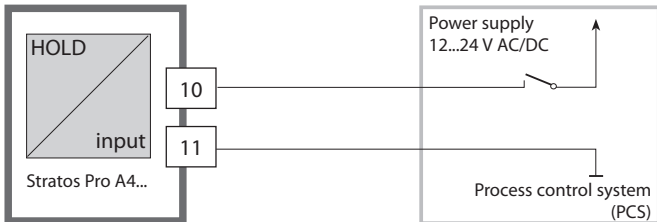

HOLD inactive	0...2 V AC/DC
HOLD active	10...30 V AC/DC

## Manual Activation of HOLD

The HOLD can be activated manually from the HOLD menu. This allows checking or replacing a sensor, for example, without provoking unintended reactions of outputs or contacts. Press **meas** key to return to selection menu.

## Alarm

When an error has occurred, **Err xx** is displayed immediately. Only after expiry of a user-defined delay time will the alarm be registered and entered in the logbook. During an alarm the display blinks, the display backlighting turns **red**.

Error messages can also be signaled by a 22 mA output current (see Configuration).

The alarm contact is activated by alarm and power failure, see also "Configuration / Alarm Settings".

2 sec after the failure event is corrected, the alarm status will be deleted.

# Configuration

## Menu Structure of Configuration

The device provides 2 parameter sets "A" and "B". By switching between the parameter sets you can adapt the device to different measurement situations, for example.

Parameter set "B" only permits setting of process-related parameters.

The configuration steps are assigned to different menu groups.

Using ◀ and ▶ you can jump between the individual menu groups.

Each menu group contains menu items for setting the parameters.

Pressing **enter** opens a menu item.

The values are edited using ▲ and ▼. Pressing **enter** confirms/stores the settings.

Return to measurement: Press **meas**.

Select menu group	Menu group	Code	Display	Select menu item
	Sensor selection	SNS:	Conf SENSOR	enter enter enter enter
		Menu item 1		
		:		
		Menu item ...		
▶	Current output 1	OT1:	Conf OUT 1	
▶	Current output 2	OT2:	Conf OUT 2	
▶	Compensation	COR:	Conf CORRECT:ON	
▶	Alarm mode	ALA:	Conf ALARM	
▶	Relay outputs	REL:	Conf REL 1/REL 2	
▶	Cleaning	WSH:	Conf WASH	◀
▶	Setting the clock	CLK:	Conf CLOCK	◀
▶	Tag number	TAG:	Conf TAG	

## Parameter Set A/B: Configurable Menu Groups



(Some parameters are identical in A and B. They are configured in parameter set A only.)

Menu group	Parameter set A	Parameter set B
SENSOR	Sensor selection	---
OUT1	Current output 1	Current output 1
OUT2	Current output 2	Current output 2
CORRECTION	Compensation	Compensation
ALARM	Alarm mode	Alarm mode
REL 1/REL 2	Relay outputs	Relay outputs
WASH	Cleaning	---
PARSET	Parameter set selection	---
CLOCK	Setting the clock	---
TAG	Tag number	---

# Configuration

## Parameter Set A/B

### Manual Selection. Signaling via WASH Contact.

Display	Action	Remark
	To switch between parameter sets: Press <b>meas</b>	Manual selection of parameter sets must have been preset in CONFIG mode. Default setting is a fixed parameter set A. Wrong settings change the measurement properties!
	PARSET blinks in the lower line. Select parameter set using ◀ and ▶ keys	
	Select PARSET A / PARSET B	
	Press <b>enter</b> to confirm. Cancel by pressing <b>meas</b>	

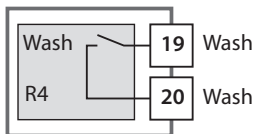

The active parameter set can be displayed using the WASH contact:

If configured correspondingly, the WASH contact signals:

“Parameter set A” (open contact)

“Parameter set B” (closed contact)

Configuration		Choices	Default
<b>SENSOR</b>			
SNS:		MEMOSENS 2-ELECTRODE 4-ELECTRODE	MEMOSENS
2-EL / 4-EL*	CELLFACTOR <sup>1)</sup>	00.0000 - 19.9999 c	01.0000 c
<p>*) These sensors appear in the menu selection but can only be used with a measuring module installed. Stratos Pro A4... MSCOND is intended for connecting a Memosens sensor via RS-485 interface. It does not provide a measuring module.</p> <p>For information on retrofitting and the respective costs, please contact the manufacturer (see back of this manual).</p>			
MEAS MODE		Cond Conc % Sal ‰ USP µS/cm	COND
Cond	MEAS RANGE <sup>2)</sup>	x.xxx µS/cm xx.xx µS/cm xxx.x µS/cm xxxx µS/cm x.xxx mS/cm xx.xx mS/cm xxx.x mS/cm x.xxx S/m xx.xx S/m xx.xx MΩ	xxx.x mS/cm
Conc	Solution	-01- (NaCl) -02- (HCl) -03- (NaOH) -04- (H <sub>2</sub> SO <sub>4</sub> ) -05- (HNO <sub>3</sub> )	-01- (NaCl)
TEMP UNIT		°C / °F	°C

- 1) With Memosens, the cell constant is automatically loaded from the sensor. When switching from Memosens to 2-/4-electrode sensor, the cell constant is set to the default value 01.0000 c and then must be entered manually.
- 2) The range selection allows selecting the maximum resolution. If the upper limit of this range is exceeded, the device automatically switches to the next higher range.

# Configuration

Configuration		Choices	Default	
<b>SENSOR</b>				
SNS	TEMPERATURE		AUTO MAN EXT (only if enabled via TAN)	AUTO
	AUTO	RTD TYPE	100 PT 1000 PT 8.55 NTC 30 NTC	100 PT
	MAN	TEMPERATURE	-50...200 °C (-58...392 °F)	025.0 °C (077.0 °F)
	CIP COUNT		ON/OFF	OFF
	SIP COUNT		ON/OFF	OFF
<b>Output 1 (OUT1)</b>				
OT1:	RANGE		0–20 mA 4–20 mA	4-20 mA
	CHANNEL		COND/TMP	COND
	OUTPUT (with Cond only)		LIN / LOG	LIN
	LIN	BEGIN 4mA (0 mA)	xxxx	000.0 mS/cm
		END 20 mA	xxxx	100.0 mS/cm
	LOG	BEGIN 4mA (0 mA)	Decades	
		END 20 mA	Decades	
	TMP °C	BEGIN 4mA (0 mA)	-50...200 °C	
		END 20 mA	-50...200 °C	
	TMP °F	BEGIN 4mA (0 mA)	-58...392 °F	
		END 20 mA	-58...392 °F	
	FILTERTIME		0... 120 SEC	0000 SEC
	22mA-FAIL		ON/OFF	OFF
	HOLD MODE		LAST/FIX	LAST
	FIX	HOLD-FIX	(0) 4...22 mA	021.0 mA

Configuration		Choices	Default		
<b>Output 2 (OUT2)</b>					
OT2:	RANGE	0–20 mA 4–20 mA	4-20 mA		
	CHANNEL	COND/TMP	TMP		
... other steps like output 1					
<b>Temperature compensation (CORRECTION)</b>					
COR:	TC SELECT		OFF LIN NLF NaCl HCL NH3	OFF	
	LIN	TC LIQUID	00.00...19.99%/K	00.00%/K	
	TEMP EXT		ON/OFF	OFF	
	ON	I-INPUT		0...20 mA/ 4...20 mA	4...20 mA
		°C	BEGIN 4 mA	-50...200 °C	000.0 °C
			END 20 mA	-50...200 °C	100.0 °C
		°F	BEGIN 4 mA	-58...392 °F	
		END 20 mA	-58...392 °F		
<b>Alarm (ALARM)</b>					
ALA:	DELAYTIME	0...600 SEC	0010 SEC		
	SENSOCHECK	ON/OFF	OFF		

# Configuration

Configuration		Choices	Default	
<b>Relay outputs (Rel1/Rel2)</b>				
REL:	Selected in text line		LIMITS CONTROLLER USP	
RL1	CHANNEL		COND/TMP	
	FUNCTION		Lo LEVEL Hi LEVEL	
	CONTACT		N/O, N/C	
	LEVEL		Within meas. range	
	HYSTERESIS		0...50% full scale	
	DELAYTIME		0000...9999 SEC	0010 SEC
RL2	CHANNEL		COND/TMP	
	FUNCTION		Lo LEVEL Hi LEVEL	
	CONTACT		N/O, N/C	
	LEVEL		Within meas. range	
	HYSTERESIS		0...50% full scale	
	DELAYTIME		0000...9999 SEC	0010 SEC
CTR	CHANNEL		COND/TMP	
	TYPE		PLC / PFC	
	PLC	PULSE LENGTH	0000...0600 SEC	0010 SEC
	PFC	PULSE FREQ.	0000...0180 P/M	0060 P/M
	SETPOINT		Within meas. range	
	DEAD BAND		0...50% full scale	
	P-GAIN		0010...9999%	0100%
	I-TIME		0000...9999 SEC	0000SEC
	D-TIME		0000...9999 SEC	0000SEC
HOLD MODE		Y LAST/Y OFF	Y LAST	

Configuration		Choices	Default
<b>Relay outputs (Rel1/Rel2)</b>			
USP:	USP FACTOR	010.0 ... 100.0 %	100.0 %
	CONTACT REL1	N/O, N/C	N/O
	DELAYTIME		0000 SEC
	CONTACT REL2	N/O, N/C	N/O
	DELAYTIME		0000 SEC
<b>Cleaning contact (WASH)</b>			
WSH:	Selected in text line	WASH PARSET A/B	WASH
	WASH    WASH CYCLE	000.0...999.9 H	000.0 h
	WASH TIME	0000...9999 SEC	0060 SEC
	CONTACT	N/O, N/C	N/O
<b>Parameter set (PARSET)</b>			
PAR:	Select fixed parameter set (A) or switch between A/B via control input or manually in measuring mode	PARSET FIX / CNTR INPUT / MANUAL	PARSET FIX (fixed parameter set A)
<b>Real-time clock (CLOCK)</b>			
CLK:	FORMAT	24 h / 12 h	
	24 h    TIME hh/mm	00..23:00...59	
	12 h    TIME hh/mm	00...11:00...59 AM/PM:	
	DAY/MONTH	01...31/01...12	
	YEAR	2000...2099	
<b>Tag number (TAG)</b>			
TAG:	(Input in text line)		—

# Configuration (Original for Copy)

---

## Default Settings of Parameter Sets

Two complete parameter sets are stored in the EEPROM. As delivered, the two sets are identical but can be edited.

**Please note:**

Fill in your configuration data on the following pages or use them as original for copy.

## Configuration (Original for Copy)

Parameter	Parameter set A	Parameter set B
SNS: Sensor type		--- *)
SNS: Cell constant		---
SNS: Measuring mode		---
SNS: Measuring range		---
SNS: Concentration determination		---
SNS: Temperature unit		---
SNS: Temp detection		---
SNS: Manual temp		---
SNS: RTD type		---
SNS: CIP counter		---
SNS: SIP counter		---
OT1: Current range		
OT1: Process variable		
OT1: LIN/LOG output		
OT1: Current start		
OT1: Current end		
OT1: Filter time		
OT1: 22 mA error current		
OT1: HOLD mode		
OT1: HOLD-FIX current		

\*) These parameters cannot be adjusted in parameter set B, the values are the same as in parameter set A.

## (Original for Copy) Configuration

<b>Parameter</b>	<b>Parameter set A</b>	<b>Parameter set B</b>
OT2: Current range		
OT2: Process variable		
OT2: LIN/LOG output		
OT2: Current start		
OT2: Current end		
OT2: Filter time		
OT2: 22 mA error current		
OT2: HOLD mode		
OT2: HOLD-FIX current		
COR: TC SELECT		
COR: Temp coefficient		
COR: Ext. temp input		
COR: Current range		
COR: Current start		
COR: Current end		
ALA: Delay		
ALA: Sensocheck on/off		
REL: Usage		
RL1: Process variable		
RL1: Function		
RL1: Contact response		
RL1: Setpoint		
RL1: Hysteresis		
RL1: Delay		
RL2: Process variable		
RL2: Function		
RL2: Contact response		

## Configuration (Original for Copy)

Parameter	Parameter set A	Parameter set B
RL2: Setpoint		
RL2: Hysteresis		
RL2: Delay		
CTR: Process variable		
CTR: Controller type		
CTR: Pulse length		
CTR: Pulse frequency		
CTR: Setpoint		
CTR: Neutral zone		
CTR: P gain		
CTR: I time		
CTR: D time		
CTR: HOLD mode		
REL: USP factor		
REL: RL1 contact		
REL: Delay		
REL: RL2 contact		
REL: Delay		
WSH: Contact function		---*)
WSH Wash cycle		---*)
WSH: Wash duration		---*)
WSH: Contact response		---*)
CLK: Time & Date		---*)
TAG: Tag number		---*)

\*) These parameters cannot be adjusted in parameter set B, the values are the same as in parameter set A.

# Configuration

## Sensor

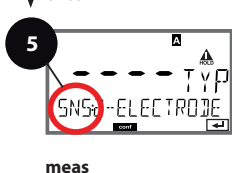
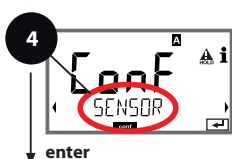

### Selecting the parameters



- 1 Press any arrow key.
- 2 Select **CONF** using ◀ ▶ keys, press **enter**.
- 3 Select parameter set using ◀ ▶ keys, press **enter**.
- 4 Select **SENSOR** menu using ◀ ▶ keys, press **enter**.
- 5 All items of this menu group are indicated by the "SNS:" code. Press **enter** to select menu, edit with arrow keys (see next page). Confirm (and proceed) with **enter**.
- 6 End: Press **meas** key until the [meas] mode indicator is displayed.

5

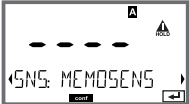
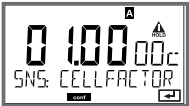
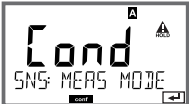
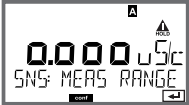
Select sensor type	enter
Enter cell constant	enter
Select measuring mode	enter
Select range	
Concentration determination	
Temperature unit	
Temperature detection	
Select type of temp probe	
Cleaning cycles	
Sterilization cycles	

Menu item	Action	Choices
Select sensor type 	Select sensor type using $\blacktriangle$ $\blacktriangledown$ keys.  Press <b>enter</b> to confirm.	<b>MEMOSENS</b> 2-ELECTRODE 4-ELECTRODE
Enter cell constant (not for Memosens) 	Modify digit using $\blacktriangle$ $\blacktriangledown$ keys, select next digit using $\blacktriangleleft$ $\blacktriangleright$ keys.  Press <b>enter</b> to confirm.	00.0000...19.9999 c <b>(01.0000 c)</b>
Select measuring mode 	Select desired measuring mode using $\blacktriangle$ $\blacktriangledown$ keys.  Press <b>enter</b> to confirm.	<b>Cond</b> Conc % Sal ‰ USP $\mu$ S/cm
Select range 	<b>For cond measurement only</b>  Select desired range using $\blacktriangle$ $\blacktriangledown$ keys.  Press <b>enter</b> to confirm.	x.xxx $\mu$ S/cm, xx.xx $\mu$ S/cm xxx.x $\mu$ S/cm, xxxx $\mu$ S/cm x.xxx mS/cm, xx.xx mS/cm <b>xxx.x mS/cm</b> , x.xxx S/m xx.xx S/m, xx.xx M $\Omega$
Concentration determination 	<b>For conc measurement only</b>  Select desired concentration solution using $\blacktriangle$ $\blacktriangledown$ keys.  Press <b>enter</b> to confirm.	<b>-01- (NaCl)</b> -02- (HCl) -03- (NaOH) -04- (H2SO4) -05- (HNO3)

# Configuration

## Sensor

Select: Temperature unit, temperature detection, type of temp probe



enter



enter

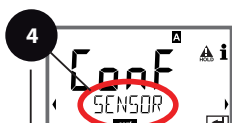

enter

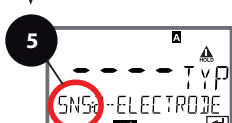





meas

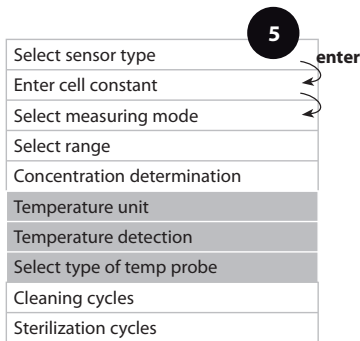

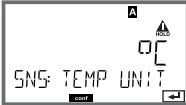
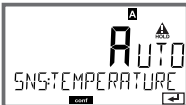
- 1 Press any arrow key.
- 2 Select **CONF** using ◀ ▶ keys, press **enter**.
- 3 Select parameter set using ◀ ▶ keys, press **enter**.
- 4 Select **SENSOR** menu using ◀ ▶ keys, press **enter**.
- 5 All items of this menu group are indicated by the "SNS:" code.  
Press **enter** to select menu, edit with arrow keys (see next page). Confirm (and proceed) with **enter**.
- 6 End: Press **meas** key until the [meas] mode indicator is displayed.



Menu item	Action	Choices
Temperature unit 	Select °C or °F using ▲ ▼ keys.  Press <b>enter</b> to confirm.	°C / °F
Temperature detection 	Select mode using ▲ ▼ : AUTO: Measured by sensor MAN: Direct input of temperature, no measurement (see next step) EXT: Temperature specified via current input (only if TAN E enabled) Press <b>enter</b> to confirm.	<b>AUTO</b> <b>MAN</b> <b>EXT</b>
(Manual temperature) 	Modify digit using ▲ ▼ keys, select next digit using ◀ ▶ keys. Press <b>enter</b> to confirm.	-50...200 °C (-58...+392 °F)
Select type of temp probe  	(not for Memosens) Select type of temperature probe using ▲ ▼ keys.  Press <b>enter</b> to confirm.	<b>100 PT</b> <b>1000 PT</b> <b>30 NTC</b> <b>8.55 NTC</b>

# Configuration

## Sensor

### Adjust: Cleaning cycles, sterilization cycles



enter



enter

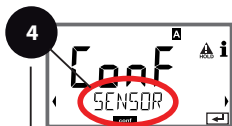

enter

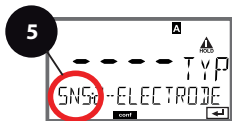



meas

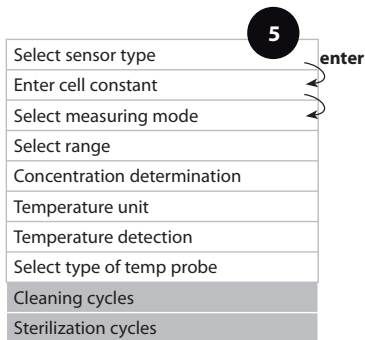

- 1 Press any arrow key.
- 2 Select **CONF** using ◀ ▶ keys, press **enter**.
- 3 Select parameter set using ◀ ▶ keys, press **enter**.
- 4 Select **SENSOR** menu using ◀ ▶ keys, press **enter**.
- 5 All items of this menu group are indicated by the "SNS:" code.  
Press **enter** to select menu, edit with arrow keys (see next page). Confirm (and proceed) with **enter**.
- 6 End: Press **meas** key until the [meas] mode indicator is displayed.



Menu item	Action	Choices
<b>CIP / SIP</b>		
Cleaning cycles On / Off 	Select ON or OFF using ▲ ▼ keys. Activates/deactivates log- ging in extended logbook Press <b>enter</b> to confirm.	<b>ON/OFF</b>
Sterilization cycles On / Off 	Select ON or OFF using ▲ ▼ keys. Activates/deactivates log- ging in extended logbook Press <b>enter</b> to confirm.	<b>ON/OFF</b>

**Please note:**

A CIP or SIP cycle is only entered into the logbook 2 hours after the start to ensure that the cycle is complete.

# Configuration

## Current Output 1

### Output current range, process variable



enter



enter

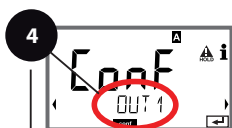

enter



meas



- 1 Press any arrow key.
- 2 Select **CONF** using ◀ ▶ keys, press **enter**.
- 3 Select parameter set using ◀ ▶ keys, press **enter**.
- 4 Select **OUT1** menu using ◀ ▶ keys, press **enter**.
- 5 All items of this menu group are indicated by the "OT1:" code. Press **enter** to select menu, edit with arrow keys (see next page). Confirm (and proceed) with **enter**.
- 6 End: Press **meas** key until the [meas] mode indicator is displayed.





5

Current range	enter
Process variable	enter
LIN/LOG output*	enter
Current start	
Current end	
Time averaging filter	
Output current during error message	
Output current during HOLD	
Output current for HOLD FIX	

\*) Selectable decades with logarithmic setting (LOG):

S/cm: 1.0  $\mu$ S/cm, 10.0  $\mu$ S/cm, 100.0  $\mu$ S/cm, 1.0 mS/cm, 10.0 mS/cm, 100.0 mS/cm, 1000 mS/cm

S/M: 0.001 S/m, 0.01 S/m, 0.1 S/m, 1.0 S/m, 10.0 S/m, 100 S/m

Menu item	Action	Choices
Current range 	Select 4-20 mA or 0-20 mA range using $\uparrow$ $\downarrow$ keys.  Press <b>enter</b> to confirm.	<b>4-20 mA</b> / 0-20 mA
Process variable 	Select using $\uparrow$ $\downarrow$ keys: Cond: Conductivity TMP: Temperature Press <b>enter</b> to confirm. Then select characteristic (LIN/LOG).	<b>Cond/TMP</b> 
Current start 	Modify digit using $\uparrow$ $\downarrow$ keys, select next digit using $\leftarrow$ $\rightarrow$ keys.  Press <b>enter</b> to confirm.	As selected for process variable/range If the adjusted range is exceeded, the device automatically switches to the next higher range (Autorange)
Current end 	Enter value using $\uparrow$ $\downarrow$ $\leftarrow$ $\rightarrow$ keys.  Press <b>enter</b> to confirm.	As selected for process variable/range If the adjusted range is exceeded, the device automatically switches to the next higher range (Autorange)

### Assignment of measured values: Current start and current end

Example 1: Range 0...200 mS/cm

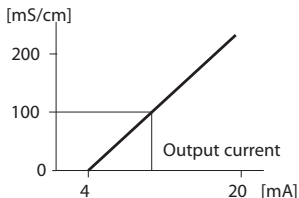

Example 2: Range 100...200 mS/cm

Advantage: Higher resolution in range

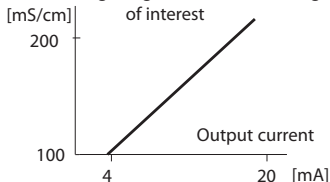

# Configuration

## Current Output 1

### Adjust time interval of output filter



enter



enter



enter



meas



- 1 Press any arrow key.
- 2 Select **CONF** using ◀ ▶ keys, press **enter**.
- 3 Select parameter set using ◀ ▶ keys, press **enter**.
- 4 Select **OUT1** menu using ◀ ▶ keys, press **enter**.
- 5 All items of this menu group are indicated by the "OT1:" code. Press **enter** to select menu, edit with arrow keys (see next page). Confirm (and proceed) with **enter**.
- 6 End: Press **meas** key until the [meas] mode indicator is displayed.

5

Current range	enter
Process variable	enter
LIN/LOG output	enter
Current start	
Current end	
Time averaging filter	
Output current during error message	
Output current during HOLD	
Output current for HOLD FIX	

Menu item	Action	Choices
Time averaging filter 	Enter value using ▲ ▼ ◀ ▶ keys.  Press <b>enter</b> to confirm.	0...120 SEC (0000 SEC)

### Time averaging filter (attenuation)

To smoothen the current output, a low-pass filter with adjustable filter time constant can be switched on. When there is a jump at the input (100 %), the output level is at 63 % after the time interval has been reached.

The time interval can be set from 0 to 120 sec.

If the time interval is set to 0 sec, the current output directly follows the input.

#### Please note:

The filter only acts on the current output, not on the display, the limit values, or the controller!

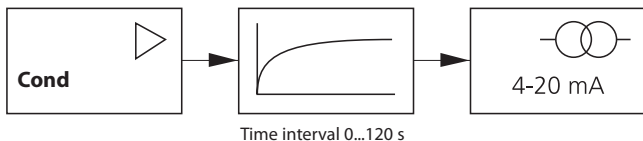

# Configuration

## Current Output 1

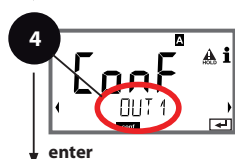

### Output current during Error and HOLD



- 1 Press any arrow key.
- 2 Select **CONF** using ◀ ▶ keys, press **enter**.
- 3 Select parameter set using ◀ ▶ keys, press **enter**.
- 4 Select **OUT1** menu using ◀ ▶ keys, press **enter**.
- 5 All items of this menu group are indicated by the "OT1:" code. Press **enter** to select menu, edit with arrow keys (see next page). Confirm (and proceed) with **enter**.
- 6 End: Press **meas** key until the [meas] mode indicator is displayed.

5

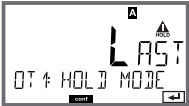
Current range	enter
Process variable	enter
LIN/LOG output	enter
Current start	
Current end	
Time averaging filter	
Output current during error message	
Output current during HOLD	
Output current for HOLD FIX	

Menu item	Action	Choices
Output current during error message	Select ON or OFF using $\blacktriangle$ $\blacktriangledown$ keys. Press <b>enter</b> to confirm.	ON/OFF
		
Output current during HOLD	LAST: During HOLD the last measured value is maintained at the output. FIX: During HOLD a value (to be entered) is maintained at the output. Select using $\blacktriangle$ $\blacktriangledown$ Press <b>enter</b> to confirm.	LAST/FIX
		
Output current for HOLD FIX	Only with FIX selected: Enter current which is to flow at the output during HOLD Enter value using $\blacktriangle$ $\blacktriangledown$ $\blacktriangleleft$ $\blacktriangleright$ keys.  Press <b>enter</b> to confirm.	00.00...22.00 mA (21.00 mA)
		

### Output Signal During HOLD:

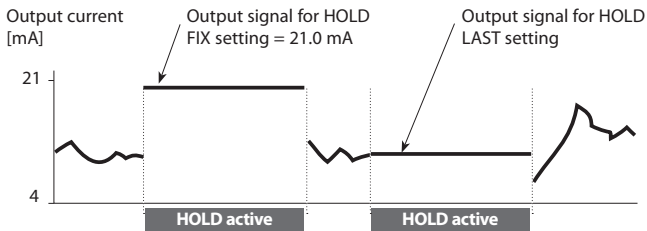

# Configuration

## Current Output 2

### Output current range, process variable



enter



enter



enter



meas



- 1 Press any arrow key.
- 2 Select **CONF** using ◀ ▶ keys, press **enter**.
- 3 Select parameter set using ◀ ▶ keys, press **enter**.
- 4 Select **OUT2** menu using ◀ ▶ keys, press **enter**.
- 5 All items of this menu group are indicated by the "OT2:" code. Press **enter** to select menu, edit with arrow keys (see next page). Confirm (and proceed) with **enter**.
- 6 End: Press **meas** key until the [meas] mode indicator is displayed.

5

Current range	enter
Process variable	enter
LIN/LOG output	
Current start	
Current end	
Time averaging filter	
Output current during error message	
Output current during HOLD	
Output current for HOLD FIX	

Menu item	Action	Choices
Current range	Select 4-20 mA or 0-20 mA range using ▲ ▼ keys.  Press <b>enter</b> to confirm.	<b>4-20 mA</b> / 0-20 mA
Process variable	Select using ▲ ▼ keys: Cond: Conductivity TMP: Temperature  Press <b>enter</b> to confirm.	Cond/TMP Begin: 0 °C End: 100°C
. . .		

**All the following adjustments are made as for current output 1 (see there)!**

# Configuration

## Temperature Compensation

### Selecting the compensation method



enter



enter



enter



meas



- 1 Press any arrow key.
- 2 Select **CONF** using ◀ ▶ keys, press **enter**.
- 3 Select parameter set using ◀ ▶ keys, press **enter**.
- 4 Select **CORRECTION** menu using ◀ ▶ keys, press **enter**.
- 5 All items of this menu group are indicated by the "COR:" code. Press **enter** to select menu, edit with arrow keys (see next page). Confirm (and proceed) with **enter**.
- 6 End: Press **meas** key until the [meas] mode indicator is displayed.







5 Temperature compensation

Current input for external temperature measurement

Current start

Current end

enter

Menu item	Action	Choices
Temperature compensation	Select desired compensation using ▲ ▼ keys:	
	<b>OFF:</b> Temperature compensation switched off	
	<b>LIN:</b> Linear temperature compensation with entry of temperature coefficient	
	<b>nLF:</b> Temperature compensation for natural waters to EN 27888	
	<b>NaCl:</b> Temperature compensation for ultrapure water with NaCl traces	
	<b>HCl:</b> Temperature compensation for ultrapure water with HCl traces	
	<b>NH3:</b> Temperature compensation for ultrapure water with NH <sub>3</sub> traces	
	Press <b>enter</b> to confirm.	

# Configuration

## Temperature Compensation

### TC process medium, current input for temp measurement



enter



enter



enter







meas

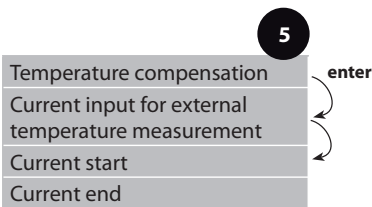

- 1 Press any arrow key.
- 2 Select **CONF** using ◀ ▶ keys, press **enter**.
- 3 Select parameter set using ◀ ▶ keys, press **enter**.
- 4 Select **CORRECTION** menu using ◀ ▶ keys, press **enter**.
- 5 All items of this menu group are indicated by the "COR:" code. Press **enter** to select menu, edit with arrow keys (see next page). Confirm (and proceed) with **enter**.
- 6 End: Press **meas** key until the [meas] mode indicator is displayed.



Menu item	Action	Choices
Temp compensation, process medium	With linear compensation only: Enter temperature compensation of the process medium. Enter value using ▲ ▼ ◀ ▶ keys. Press <b>enter</b> to confirm.	-19.99...19.99 %/K
		
Current range	Select desired range using ▲ ▼ keys. Press <b>enter</b> to confirm.	4-20 mA / 0-20 mA
		
Current start	Modify digit using ▲ ▼ keys, select next digit using ◀ ▶ keys. Press <b>enter</b> to confirm.	Input range: -50...200 °C / -58...392 °F
		
Current end	Enter value using ▲ ▼ ◀ ▶ keys. Press <b>enter</b> to confirm.	Input range: -50...200 °C / -58...392 °F
		

# Configuration

## Alarm Settings

### Delay, Sensocheck



enter



enter



enter



meas



- 1 Press any arrow key.
- 2 Select **CONF** using ◀ ▶ keys, press **enter**.
- 3 Select parameter set using ◀ ▶ keys, press **enter**.
- 4 Select **ALARM** menu using ◀ ▶ keys, press **enter**.
- 5 All items of this menu group are indicated by the "ALA:" code. Press **enter** to select menu, edit with arrow keys (see next page). Confirm (and proceed) with **enter**.
- 6 End: Press **meas** key until the [meas] mode indicator is displayed.

Delay

Sensocheck

5

enter

Menu item	Action	Choices
Delay	Enter value using ▲ ▼ ◀ ▶ keys. Press <b>enter</b> to confirm.	0...600 SEC <b>(010 SEC)</b>
Sensocheck 	Select Sensocheck (continuous monitoring of sensor). Select ON or OFF using ▲ ▼ keys. Press <b>enter</b> to confirm (At the same time, Sensoface is activated. With OFF, Sensoface is also switched off.)	ON/OFF

### Alarm Contact

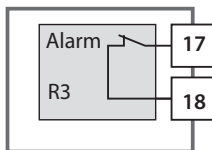

The alarm contact is closed during normal operation (N/C).

It opens in the case of alarm or power outage.

As a result, a failure message is provided even in the case of line breakage (fail-safe behavior).

For contact ratings, see Specifications.

Error messages can also be signaled by a 22 mA output current (see Error messages and Configuration Output 1/Output 2).

Operating behavior of the alarm contact: see Operating States table.

**The alarm delay time** delays the color change of the display back-lighting to red, the 22 mA signal (if configured), and the alarm contact switching.

# Configuration

## Limit Function

### Relay 1



enter



enter



enter







meas

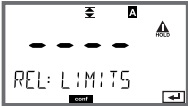

- 1 Press any arrow key.
- 2 Select **CONF** using ◀ ▶ keys, press **enter**.
- 3 Select parameter set using ◀ ▶ keys, press **enter**.
- 4 Select **REL1/REL2** menu using ◀ ▶ keys, press **enter**.
- 5 All items of this menu group are indicated by the "RL1:" code. Press **enter** to select menu, edit with arrow keys (see next page). Confirm (and proceed) with **enter**.
- 6 End: Press **meas** key until the [meas] mode indicator is displayed.

5

Use of relays	enter
Select process variable	↔
Limit 1 switching characteristics (function)	↔
Limit 1 contact type	
Limit 1 setpoint	
Limit 1 hysteresis	
Limit 1 delay	

Menu item	Action	Choices
Use of relays 	Select in the text line using ▲ ▼ keys: <ul style="list-style-type: none"> <li>• Limit function (LIMITS)</li> <li>• Controller (CONTROLLER)</li> <li>• USP function (USP FUNCT.)</li> </ul> Press <b>enter</b> to confirm.	<b>LIMITS</b> / CONTROLLER (not with Mohm as process variable!) / USP FUNCT (only with USP selected!) <b>Please note:</b> Selecting CONTROLLER leads to Controller menu group (CTR), selecting USP FUNCT to USP function menu group.
Select process variable 	Select desired process variable using ▲ ▼ keys.  Press <b>enter</b> to confirm.	<b>Cond</b> /TMP
Limit 1 function 	Select desired function using arrow keys. LoLevel: active if value falls below / HiLevel: active if value exceeds setpoint Press <b>enter</b> to confirm.	<b>Lo LEVEL</b> / Hi LEVEL
Limit 1 contact response 	N/O: normally open contact N/C: normally closed contact Select using ▲ ▼ keys. Press <b>enter</b> to confirm.	<b>N/O</b> / N/C
Limit 1 setpoint 	Enter setpoint using ▲ ▼ ◀ ▶ keys.  Press <b>enter</b> to confirm.	Within meas. range

## Limit Function

### Relay 1



enter



enter



enter





meas



- 1 Press any arrow key.
- 2 Select **CONF** using ◀ ▶ keys, press **enter**.
- 3 Select parameter set using ◀ ▶ keys, press **enter**.
- 4 Select **REL1/REL2** menu using ◀ ▶ keys, press **enter**.
- 5 All items of this menu group are indicated by the "RL1:" code. Press **enter** to select menu, edit with arrow keys (see next page). Confirm (and proceed) with **enter**.
- 6 End: Press **meas** key until the [meas] mode indicator is displayed.

5

Use of relays	enter
Select process variable	↔
Limit 1 switching characteristics (function)	↔
Limit 1 contact type	
Limit 1 setpoint	
Limit 1 hysteresis	
Limit 1 delay	

Menu item	Action	Choices
Limit 1 hysteresis 	Select hysteresis using ▲ ▼ ◀ ▶ keys.  Press <b>enter</b> to confirm.	0...50% full scale If the adjusted range is exceeded, the device automatically switches to the next higher range (Autorange)
Limit 1 delay 	The contact is activated with delay (deactivated without delay) Adjust delay using ▲ ▼ ◀ ▶ keys.  Press <b>enter</b> to confirm.	0...9999 SEC <b>(0010 SEC)</b>

## Limit Lo

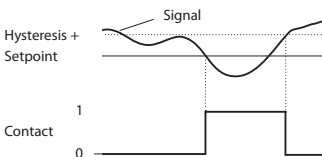

## Limit Hi

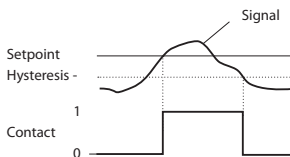

## Limit Function

### Relay 2



enter



enter



enter



meas



- 1 Press any arrow key.
- 2 Select **CONF** using ◀ ▶ keys, press **enter**.
- 3 Select parameter set using ◀ ▶ keys, press **enter**.
- 4 Select **REL1/REL2** menu using ◀ ▶ keys, press **enter**.
- 5 All items of this menu group are indicated by the "RL2:" code. Press **enter** to select menu, edit with arrow keys (see next page). Confirm (and proceed) with **enter**.
- 6 End: Press **meas** key until the [meas] mode indicator is displayed.

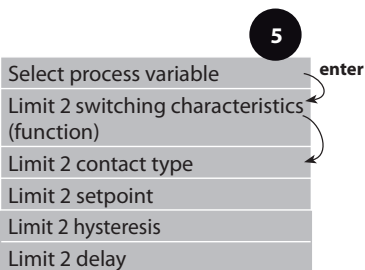

Menu item	Action	Choices
Select process variable (CHANNEL)	Select desired process variable using ▲ ▼ keys. Press <b>enter</b> to confirm.	Cond/TMP
Limit 2 function (FUNCTION)	Select desired function using ▲ ▼ arrow keys. Press <b>enter</b> to confirm.	Lo LEVEL / <b>Hi LEVEL</b>
Limit 2 contact type (CONTACT)	N/O: normally open contact N/C: normally closed contact Select using ▲ ▼ keys. Press <b>enter</b> to confirm.	<b>N/O</b> / N/C
Limit 2 setpoint (LEVEL)	Enter setpoint using ▲ ▼ ◀ ▶ keys. Press <b>enter</b> to confirm.	Within meas. range If the adjusted range is exceeded, the device automatically switches to the next higher range (Autorange)
Limit 2 hysteresis (HYSTERESIS)	Select hysteresis using ▲ ▼ ◀ ▶ keys. Press <b>enter</b> to confirm.	0...50% full scale (Autorange – see above)
Limit 2 delay (DELAYTIME)	The contact is activated with delay (deactivated without delay) Adjust delay using ▲ ▼ ◀ ▶ keys. Press <b>enter</b> to confirm.	0...9999 SEC <b>(0010 SEC)</b>

## Limit Lo

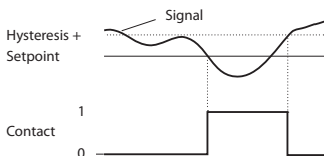

## Limit Hi

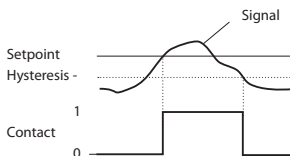



## Typical Applications

### P Controller

Application for integrating control systems (e.g. closed tank, batch processes).

### PI Controller

Application for non-integrating control systems (e.g. drains).

### PID Controller

The additional derivative action compensates for measurement peaks.

## Controller Characteristic

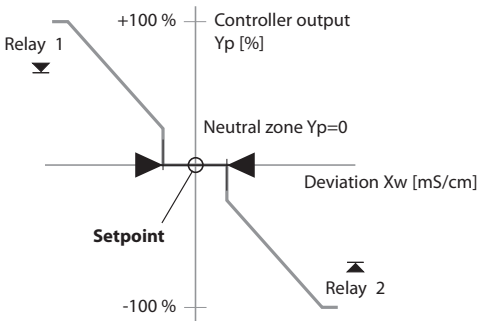

# Controller Functions

## Controller Equations

$$\text{Controller output } Y = Y_P + \frac{1}{T_R} \int Y_P dt + T_D \frac{dY_P}{dt}$$

P action                  I action                  D action

Proportional action  $Y_P$

$$Y_P = \frac{\text{Setpoint} - \text{Meas. value}}{\text{Measuring range}} * K_C$$

with:  
 $Y_P$                   Proportional action  
 $T_R$                   Reset time [s]  
 $T_D$                   Rate time [s]  
 $K_C$                   Controller gain [%]

## Neutral zone (Y=0)

Tolerated deviation from desired value.

With the setting "1 mS/cm", for example, a deviation of  $\pm 0.5$  mS/cm from the desired value does not activate the controller.

## Proportional action (Gradient $K_C$ [%])

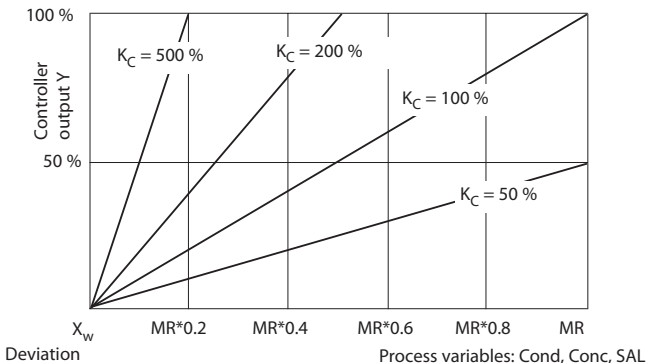

## Pulse Length / Pulse Frequency Controller

### Pulse Length Controller (PLC)

The pulse length controller is used to operate a valve as an actuator. It switches the contact on for a time that depends on the controller output. The period is constant. A minimum ON time of 0.5 sec is maintained even if the controller output takes corresponding values.

### Output signal (relay contact) of pulse length controller

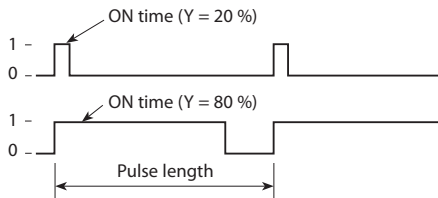

### Pulse Frequency Controller (PFC)

The pulse frequency controller is used to operate a frequency-controlled actuator (metering pump). It varies the frequency with which the contacts are switched on. The maximum pulse frequency [pulses/min] can be defined. It depends on the actuator.

The contact ON time is constant. It is automatically calculated from the user-defined maximum pulse frequency:

### Output signal (relay contact) of pulse frequency controller

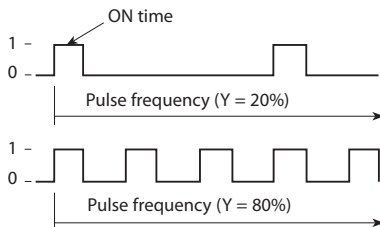

# Configuration

## Controller

(For description, see Controller Functions)

### Process variable, controller type, setpoint



enter



enter



enter







meas



- 1 Press any arrow key.
- 2 Select **CONF** using ◀ ▶ keys, press **enter**.
- 3 Select parameter set using ◀ ▶ keys, press **enter**.
- 4 Select **REL1/REL2** menu using ◀ ▶ keys, press **enter**.
- 5 All items of this menu group are indicated by the "CTR:" code. Press **enter** to select menu, edit with arrow keys (see next page). Confirm (and proceed) with **enter**.
- 6 End: Press **meas** key until the [meas] mode indicator is displayed.

5

Select process variable	enter
Controller type	↔
Pulse length	↔
Pulse frequency	
Setpoint	
Neutral zone	
Controller: P action	
Controller: I action	
Controller: D action	
Behavior during HOLD	

Menu item	Action	Choices
Select process variable 	Select desired process variable using ▲ ▼ keys.  Press <b>enter</b> to confirm.	<b>Cond/TMP</b>
Controller type 	Pulse length controller (PLC) or pulse frequency controller (PFC) Select using ▲ ▼ keys. Press <b>enter</b> to confirm.	<b>PLC / PFC</b>
Pulse length 	Only with PLC: Pulse length Adjust using ▲ ▼ ◀ ▶ keys.  Press <b>enter</b> to confirm.	0...0600 SEC <b>(0010 SEC)</b>
Pulse frequency 	Only with PFC: Pulse frequency Adjust using ▲ ▼ ◀ ▶ keys.  Press <b>enter</b> to confirm.	0...0180 P/M <b>(0060 P/M)</b>  (pulses per minute)
Setpoint 	Adjust setpoint using ▲ ▼ ◀ ▶ keys.  Press <b>enter</b> to confirm.	Within meas. range If the adjusted range is exceeded, the device automatically switches to the next higher range (Autorange)

## Controller

(For description, see Controller Functions)

### Neutral zone, P, I, D actions, behavior during HOLD



enter



enter



enter







meas



- 1 Press any arrow key.
- 2 Select **CONF** using ◀ ▶ keys, press **enter**.
- 3 Select parameter set using ◀ ▶ keys, press **enter**.
- 4 Select **REL1/REL2** menu using ◀ ▶ keys, press **enter**.
- 5 All items of this menu group are indicated by the "CTR:" code. Press **enter** to select menu, edit with arrow keys (see next page). Confirm (and proceed) with **enter**.
- 6 End: Press **meas** key until the [meas] mode indicator is displayed.

5

Select process variable	enter
Controller type	↻
Pulse length	↻
Pulse frequency	
Setpoint	
Neutral zone	
Controller: P action	
Controller: I action	
Controller: D action	
Behavior during HOLD	

Menu item	Action	Choices
Neutral zone 	Adjust neutral zone using ▲ ▼ ◀ ▶ keys.  Press <b>enter</b> to confirm.	0...50% full scale If the adjusted range is exceeded, the device automatically switches to the next higher range (Autorange)
Controller: P action 	Adjust P action using ▲ ▼ ◀ ▶ keys.  Press <b>enter</b> to confirm.	10...9999% <b>(0100%)</b>
Controller: I action 	Adjust I action using ▲ ▼ ◀ ▶ keys.  Press <b>enter</b> to confirm.	0...9999 SEC <b>(0000 SEC)</b>
Controller: D action 	Adjust D action using ▲ ▼ ◀ ▶ keys.  Press <b>enter</b> to confirm.	0...9999 SEC <b>(0000 SEC)</b>
Behavior during HOLD 	Select response using ▲ ▼ keys.  Press <b>enter</b> to confirm.	<b>Y LAST / Y OFF</b>

# Configuration

## WASH Contact

Control of rinsing probes or signaling the parameter set



enter



enter



enter







meas

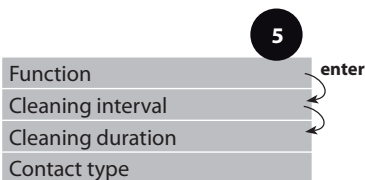

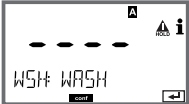
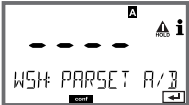
- 1 Press any arrow key.
- 2 Select **CONF** using ◀ ▶ keys, press **enter**.
- 3 Select parameter set A using ◀ ▶ keys, press **enter**.
- 4 Select **WASH** menu using ◀ ▶ keys, press **enter**.
- 5 All items of this menu group are indicated by the "WSH:" code. Press **enter** to select menu, edit with arrow keys (see next page). Confirm (and proceed) with **enter**.
- 6 End: Press **meas** key until the [meas] mode indicator is displayed.



Menu item	Action	Choices
Function  	Select WASH contact function using $\blacktriangle$ $\blacktriangledown$ keys.  Press <b>enter</b> to confirm.	<b>WASH</b> / PARSET A/B  WASH: Control of rinsing probes  With PARSET A/B selected, the contact signals: "Parameter set A" (open contact) "Parameter set B" (closed contact)
Cleaning interval 	Only with WASH: Adjust value using $\blacktriangle$ $\blacktriangledown$ $\blacktriangleleft$ $\blacktriangleright$ keys.  Press <b>enter</b> to confirm.	0.0...999.9 h ( <b>000.0 h</b> )
Cleaning duration 	Only with WASH: Adjust value using $\blacktriangle$ $\blacktriangledown$ $\blacktriangleleft$ $\blacktriangleright$ keys.  Press <b>enter</b> to confirm.	0...9999 SEC ( <b>0060 SEC</b> )
Contact type 	Only with WASH: N/O: normally open contact N/C: normally closed contact Select using $\blacktriangle$ $\blacktriangledown$ keys. Press <b>enter</b> to confirm.	<b>N/O</b> / N/C

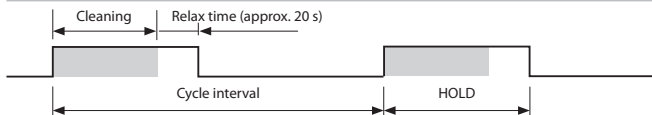

# Configuration

## Time and Date Tag Number

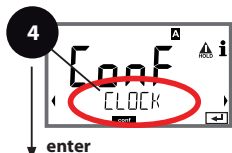

- 1 Press any arrow key.
- 2 Select **CONF** using ◀ ▶ keys, press **enter**.
- 3 Select parameter set A using ◀ ▶ keys, press **enter**.
- 4 Press **enter**
- 5 Select **CLOCK** or **TAG** using ◀ ▶ keys, press **enter**.
- 6 All items of this menu group are indicated by the "CLK:" or "TAG" code. Press **enter** to select menu, edit with arrow keys (see next page). Confirm (and proceed) with **enter**.
- 7 End: Press **meas** key until the [meas] mode indicator is displayed.

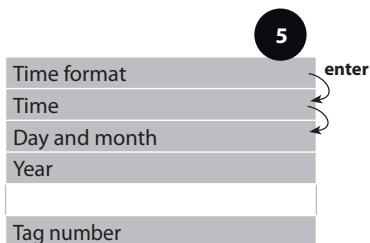

## Time and Date

Control of the calibration and cleaning cycles is based on the time and date of the integrated real-time clock.

In measuring mode the time is shown in the lower display.

When using digital sensors, the calibration data is written in the sensor head.

In addition, the logbook entries (cf Diagnostics) are provided with a time stamp.

### Please note:

- After prolonged power outage (> 5 days) the time display is replaced by dashes and cannot be used for processing. Enter the correct time.
- There is no automatic switchover from winter to summer time! Be sure to manually adjust the time!

## Tag Number ("TAG")

You can enter a designation for the point of measurement (tag number) in the lower display line. Up to 32 digits are possible.

Pressing **meas** (repeatedly) in the measuring mode indicates the tag number.

Being part of the device configuration, the "TAG" can be read out via IrDA.

A standardized tag number helps, for example, to correctly re-install a device after repair.

5

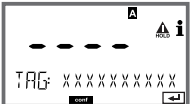
Menu item	Action	Choices
Tag number 	Select character using ▲ ▼ keys, select next digit using ◀ ▶ keys.  Press <b>enter</b> to confirm.	A...Z, 0...9, - + < > ? / @  The first 10 characters are seen in the display with- out scrolling.

# Digital Sensors

---

## Operation

Stratos Pro can be operated with digital Memosens sensors. The following display examples refer to a transmitter and a digital sensor (slight variations for other combinations).



The sensor type is selected during **Configuration**. The device only switches to measuring mode when the connected sensor corresponds to the type configured (Sensoface is friendly):

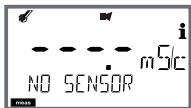

Otherwise, an error message is released. The **info** icon is displayed. You can display the error text in the bottom line using the ◀ ▶ keys. Sensoface is sad (see table of error messages and Sensoface in the Appendix):



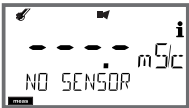

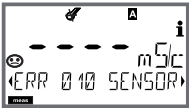
## Connecting a Digital Sensor

Step	Action/Display	Remark
Connect sensor		Before a digital sensor is connected, the error message „No sensor“ is displayed.
Wait until the sensor data are displayed.		The hourglass in the display blinks.
Check sensor data	 <p>View sensor information using ◀ ▶ keys, press <b>enter</b> to confirm.</p>	Display color changes to <b>green</b> .  Sensoface is friendly when the sensor data are okay.
Go to measuring mode	Press <b>meas</b> , <b>info</b> , or <b>enter</b>	After 60 sec the device automatically returns to measuring mode (time-out).
Possible error messages		
Sensor defective. Replace sensor		When this error message appears, the sensor cannot be used. Sensoface is sad.

## Sensor Replacement

A digital sensor should only be replaced during HOLD mode to prevent unintended reactions of the outputs or contacts. When you first want to calibrate the new sensor, it can also be replaced in calibration mode.

Step	Action/Display	Remark
Select HOLD mode	Press any key to call the selection menu, select HOLD using the ◀ ▶ keys, press <b>enter</b> to confirm.	Now the device is in HOLD mode. The HOLD mode can also be activated externally via the HOLD input. During HOLD the output current is frozen at its last value or set to a fixed value.
Disconnect and remove old sensor		
Install and connect new sensor.		Temporary messages which are activated during the replacement are indicated but not output to the alarm contact and not entered in the log-book.
Wait until the sensor data are displayed.		

Step	Action/Display	Remark
Check sensor data	 <p>View sensor information using ◀ ▶ keys, press <b>enter</b> to confirm.</p>	You can view the sensor type, serial number, and last calibration date.
Check measured values		
Exit HOLD	Hit <b>meas</b> key: Return to selection menu. Hold <b>meas</b> key depressed: Device switches to measuring mode	The sensor replacement is entered in the extended logbook.



# Calibration

---

## **Please note:**

- All calibration procedures must be performed by trained personnel. Incorrectly set parameters may go unnoticed, but change the measuring properties.

Calibration can be performed by:

- Determining the cell constant with a known calibration solution
- Input of cell constant (e.g. for ultrapure-water sensors)
- Sampling (product calibration)
- Temperature probe adjustment

## Selecting a Calibration Mode





Calibration adapts the device to the individual sensor characteristics. Access to calibration can be protected with a passcode (SERVICE menu).

First, you open the calibration menu and select the calibration mode:



CAL_SOL	Calibration with calibration solution
CAL_CELL	Calibration by entry of cell constant
P_CAL	Product calibration (calibration with sampling)
CAL_RTD	Temperature probe adjustment

# Calibration with Calibration Solution

Input of temperature-corrected value of calibration solution with simultaneous display of cell constant

Display	Action	Remark
	Select Calibration. Press <b>enter</b> to proceed. Select CAL_SOL calibration method. Press <b>enter</b> to proceed.	
	Ready for calibration. Hourglass blinks.	Display (3 sec) Now the device is in HOLD mode.
	Immerse sensor in calibration solution. Enter the temperature-corrected value of the calibration solution using the arrow keys (see table). Press <b>enter</b> to confirm.	Lower line: Display of cell constant and temperature
	The determined cell constant is displayed. The "hourglass" icon is blinking. Press <b>enter</b> to proceed.	

## Calibration with Calibration Solution





Display	Action	Remark
	Display of selected process variable (here: mS/cm). Now the device is in HOLD mode: Reinstall the sensor and check whether the message is OK. MEAS ends calibration, REPEAT permits repetition.	
	With MEAS selected: End calibration by pressing <b>enter</b> .	Display of conductivity and temperature, Sensoface is active. After end of calibration, the outputs remain in HOLD mode for a short time. After display of GOOD BYE, the device automatically returns to measuring mode.

### Please note:

- Be sure to use known calibration solutions and the respective temperature-corrected conductivity values (see table on calibration solution).
- During the calibration procedure the temperature must be kept constant.

## Calibration by Entry of Cell Constant

You can directly enter the value for the cell constant of a sensor. This value must be known, e.g. determined beforehand in the laboratory. The selected process variable and the temperature are displayed.

Display	Action	Remark
	Select Calibration. Press <b>enter</b> to proceed. Select CAL_CELL calibration method. Press <b>enter</b> to proceed.	
	Ready for calibration. Hourglass blinks.	Display (3 sec) Now the device is in HOLD mode.
	Enter cell constant. Press <b>enter</b> to proceed.	The selected process variable and the temperature are displayed.
	The device shows the calculated cell constant (at 25 °C). Sensoface is active.	
	<b>Use the arrow keys to select:</b> • MEAS (end) • REPEAT Press <b>enter</b> to proceed.	End: HOLD is deactivated after a short time.

# Product Calibration

Calibration by sampling – for product calibration, the uncompensated conductivity ( $\mu\text{S/cm}$ ,  $\text{mS/cm}$ ,  $\text{S/m}$ ) is used.

During product calibration the sensor remains in the process.

The measurement process is only interrupted briefly.

## Procedure:



1) The sample is measured in the lab or directly on the site using a portable meter. To ensure an exact calibration, the sample temperature should correspond to the measured process temperature.

During sampling the device saves the currently measured value and then returns to measuring mode. Then, the “calibration” mode indicator blinks.





2) In the second step you enter the measured sample value in the device. From the difference between the stored measured value and entered sample value, the device calculates the new cell constant.

If the sample is invalid, you can take over the value stored during sampling. In that case the old calibration values are stored.





Afterwards, you can start a new product calibration.

Display	Action	Remark
	Select Calibration. Press <b>enter</b> to proceed. Select P_CAL calibration method. Press <b>enter</b> to proceed.	
	Ready for calibration. Hourglass blinks.	Display (3 sec) Now the device is in HOLD mode.
	Take sample and save value. Press <b>enter</b> to proceed.	Now the sample can be measured in the lab.



## Product Calibration

Display	Action	Remark
	The device returns to measuring mode.	From the blinking CAL mode indicator you see that product calibration has not been terminated.
	<b>Product calibration step 2:</b> When the sample value has been determined, open the product calibration once more	Display (3 sec) Now the device is in HOLD mode.
	The stored value is displayed (blinking) and can be overwritten with the lab value. Press <b>enter</b> to proceed.	
	Display of new cell constant (based on 25°C). Sensoface is active. To end calibration: Select <b>MEAS</b> , then <b>enter</b>	To repeat calibration: Select <b>REPEAT</b> , then <b>enter</b>
	After calibration is ended, the device will switch to measuring mode.	After end of calibration, the outputs remain in HOLD mode for a short time.

## Temp Probe Adjustment

Display	Action	Remark
	Select Calibration. Press <b>enter</b> to proceed. Select CAL_RTD calibration method. Press <b>enter</b> to proceed.	Wrong settings change the measurement properties!
	Measure the tempera- ture of the process medium using an external thermometer.	Display (3 sec) Now the device is in HOLD mode.
	Enter the measured temperature value. Maximum difference: 10 K. Press <b>enter</b> to proceed.	Display of actual temperature (un- compensated) in the lower display.
	The corrected tempera- ture value is displayed. Sensoface is active. To end calibration: Select MEAS, then <b>enter</b> To repeat calibration: Select REPEAT, then <b>enter</b>	After end of calibra- tion, the outputs re- main in HOLD mode for a short time.
	After calibration is ended, the device will switch to measuring mode.	

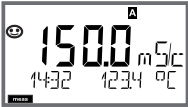
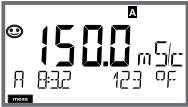
# Measurement

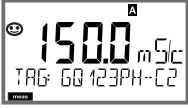
Display	Remark
 <p>or AM/PM and °F:</p> 	<p>From the configuration or calibration menus, you can switch the device to measuring mode by pressing the <b>meas</b> key. In the measuring mode the main display shows the configured process variable, the secondary display shows the time and the second configured process variable. The [meas] mode indicator lights and the active parameter set (A/B) is indicated. A/B is not displayed with parameter set Fix A.</p> <p><b>Please note:</b></p> <ul style="list-style-type: none"><li>• After prolonged power outage (&gt; 5 days) the time display is replaced by dashes and cannot be used for processing. Enter the correct time.</li></ul>
<p>Pressing the <b>enter</b> key briefly shows the output currents. By pressing the <b>meas</b> key you can step through the following displays. When no key has been pressed for 60 sec, the device returns to the standard display.</p>	
 	<p>Selecting the parameter set (if set to "manual" in the configuration). Select the desired parameter set using the ◀ ▶ arrow keys (PARSET A or PARSET B blinks in the lower display line). Press <b>enter</b> to confirm.</p> <p>Further displays (each with <b>meas</b>).</p> <ol style="list-style-type: none"><li>1) Display of tag number ("TAG")</li><li>2) Display of time and date</li></ol>

Display	Remark
<b>With activated controller</b>	you can also step through the following displays by pressing the <b>meas</b> key. When no key has been pressed for 60 sec, the device returns to the standard display.
 The image shows a rectangular LCD display. The main display area shows the number '50.00' in a large, bold, black font. To the left of the number is a small icon of a smiley face with a plus sign. Above the number is a small 'A' icon. To the right of the number are two small square icons. Below the main display, there is a secondary display showing '5002 mS'. In the bottom right corner of the display area, there is a small icon of a left-pointing arrow. The entire display is enclosed in a thin black border.	Main display: Controller output Y Secondary display: Setpoint Depending on configuration setting: conductivity or temperature.



In the Diagnostics mode you can access the following menus without interrupting the measurement:

CALDATA	Viewing the calibration data
SENSOR	Viewing the sensor data
SELFTEST	Starting a device self-test
LOGBOOK	Viewing the logbook entries
MONITOR	Displaying currently measured values
VERSION	Displaying device type, software version, serial number

Access to diagnostics can be protected with a passcode (SERVICE menu).





**Please note:**

HOLD is not active during Diagnostics mode!







Action	Key	Remark
Activate Diagnostics		Press any arrow key to call the selection menu. (Display color changes to turquoise.) Select DIAG using ◀ ▶ keys, press <b>enter</b> to confirm.
Select diagnostics option		Use ◀ ▶ keys to select from: CALDATA SENSOR SELFTEST LOGBOOK MONITOR VERSION See next pages for further proceeding.
End	<b>meas</b>	End by pressing <b>meas</b> .

# Diagnostics

Menu item	Remark
 <p>The screenshot shows a digital display with 'd 1A6' on the top line. The bottom line shows 'CALDATA LO' with a left arrow on the left and a right arrow on the right. A 'meas' button is visible at the bottom center.</p>	<p><b>Display of calibration data</b></p> <p>Select CALDATA using ◀ ▶, press <b>enter</b> to confirm. Use the ◀ ▶ keys to select the desired parameter from the bottom line of the display (LAST_CAL CELLFACTOR ZERO). The selected parameter is shown in the main display.</p> <p>Press <b>meas</b> to return to measurement.</p>

Display	Menu item
	<p><b>Device self-test</b> (To abort, you can press <b>meas</b>.)</p>
	<p>1 <b>Display test:</b> Display of all segments with changing background colors white/green/red. Press <b>enter</b> to proceed.</p> <p>2 <b>RAM test:</b> Hourglass blinks, then display of --PASS-- or --FAIL-- Press <b>enter</b> to proceed.</p>
	<p>3 <b>EEPROM test:</b> Hourglass blinks, then display of --PASS-- or --FAIL-- Press <b>enter</b> to proceed.</p>
	<p>4 <b>FLASH test:</b> Hourglass blinks, then display of --PASS-- or --FAIL-- Press <b>enter</b> to proceed.</p>
	<p>5 <b>Module test:</b> Hourglass blinks, then display of --PASS-- or --FAIL-- Press <b>enter</b> or <b>meas</b> to return to measuring mode.</p>

# Diagnostics

Menu item	Remark
  	<p><b>Display of logbook entries.</b> Select LOGBOOK using ◀ ▶, press <b>enter</b> to confirm.</p> <p>By using the ▲ ▼ keys, you can scroll backwards and forwards through the logbook (entries -00-...-99-), -00- being the last entry.</p> <p>By using the ◀ ▶ keys, you can view a logbook entry.</p> <p>Press <b>meas</b> to return to measurement.</p>
	<p><b>Extended logbook / Audit Trail (via TAN)</b> By using the ▲ ▼ keys, you can scroll backwards and forwards through the extended logbook (entries -000-...-199-), -000- being the last entry.</p> <p><b>Display: CFR</b> Audit Trail also records function activations (CAL CONFIG SERVICE), some Sensoface messages, and opening of the enclosure.</p>
 Display example: 	<p><b>Display of currently measured values (sensor monitor):</b> Select MONITOR using ◀ ▶, press <b>enter</b> to confirm. Use the ◀ ▶ keys to select the desired parameter from the bottom line of the display (R_COND G_COND RTD TEMP I-INPUT (Option)). The selected parameter is shown in the main display.</p> <p>Press <b>meas</b> to return to measurement.</p>

Display	Remark
 A screenshot of a device's LCD display. The display shows the number '10.2' in large digits at the top. To the right of '10.2' is the text 'SW'. Below '10.2' is the text 'SERIAL-NO' followed by '0073'. There are small navigation icons on the left and right sides of the display.	<p><b>Version</b></p> <p>Here, you find the data you require for requesting a device-specific Option.</p> <p>Display of <b>device type</b>, <b>software/hardware version</b>, and <b>serial number</b> for all device components.</p> <p>Use the ▲ ▼ keys to switch between software and hardware version. Press <b>enter</b> to proceed to next device component.</p>



# Service





In the Service mode you can access the following menus:



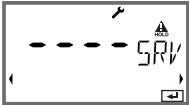

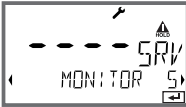
MONITOR	Displaying currently measured values
OUT1	Testing current output 1
OUT2	Testing current output 2
RELAY	Testing the function of the 4 relays
CONTROL	Testing the controller function
IRDA	Activating and communicating via the IrDA interface
CODES	Assigning and editing passcodes
DEFAULT	Resetting the device to factory settings
OPTION	Enabling options via TAN.

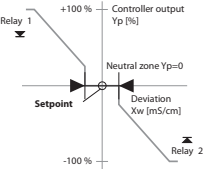

## Please note:

HOLD is active during Service mode!

Action	Key/Display	Remark
Activate Service		Press any arrow key to call the selection menu. Select SERVICE using ◀ ▶ keys, confirm with <b>enter</b>
Passcode		Enter passcode "5555" for service mode using the ▲ ▼ ◀ ▶ keys. Press <b>enter</b> to confirm.
Display		In service mode the following icons are displayed: <ul style="list-style-type: none"><li>• HOLD triangle</li><li>• Service (wrench)</li></ul>
End	<b>meas</b>	End with <b>meas</b> .

Menu item	Remark
 <p>Display example:</p> 	<p><b>Display of currently measured values (sensor monitor) with HOLD mode activated:</b>            Select MONITOR using ◀ ▶, press <b>enter</b> to confirm.            Select variable in the bottom text line using ◀ ▶.</p> <p>The selected parameter is shown in the main display. As the device is in HOLD mode, you can perform validations using simulators without influencing the signal outputs.</p> <p>Press <b>meas</b> to return to the service menu.            Return to measurement: Press <b>meas</b> once more.</p>
	<p><b>Specify current at outputs 1 and 2:</b>            Select OUT1 or OUT2 using the ◀ ▶ keys, press <b>enter</b> to confirm.            Enter a valid current value for the respective output using ▲ ▼ ◀ ▶ keys.            Press <b>enter</b> to confirm.</p> <p>For checking purposes, the actual output current is shown in the bottom right corner of the display.            End by pressing <b>enter</b> or <b>meas</b>.</p>
 <p>REL1 REL2 ALARM WASH</p>	<p><b>Relay test (manual test of contacts):</b>            Select RELAIS using ◀ ▶, press <b>enter</b> to confirm.            Now the status of the 4 relays is "frozen". The 4 digits of the main display represent the respective states (from left to right: REL1, REL2, ALARM, WASH). The digit for the selected relay blinks.            Select one of the 4 relays using the ◀ ▶ keys, close (1) or open (0) using the ▲ ▼ keys.            End by pressing <b>enter</b>. The relays will be re-set corresponding to the measured value.</p> <p>Press <b>meas</b> to return to measurement.</p>

Menu item	Remark
 <p><b>Controller characteristic</b></p>  <p>The arrows indicate which relay (valve) is active:</p> <ul style="list-style-type: none"> <li>▲ Relay 2 active (Meas. value &gt; setpoint)</li> <li>▼ Relay 2 active (Meas. value &lt; setpoint)</li> </ul>	<p><b>Controller test (manual specification of controller output):</b>            This function is used to start up control loops or check the actuators.            For bumpless changeover to automatic operation (exiting this function), configure an I-action component (reset time).</p> <p>The lower display shows the currently adjusted controller output Yp.</p> <p>Specify new value for controller output Yp:            Enter sign and value in the main display using the ▲ ▼ ◀ ▶ keys. Press <b>enter</b> to confirm.</p> <p>The new value is taken into the lower display.</p> <p>Press <b>enter</b> or <b>meas</b> to return to the service menu.            Return to measurement: Press <b>meas</b> once more.</p> <p>Controller output -100...0%    Relay 2 active</p> <p>Controller output 0...+100%    Relay 1 active</p>
	<p><b>IrDA communication:</b>            Select IRDA using ◀ ▶ , press <b>enter</b> to confirm.</p>
 	<p>When IrDA communication is active, the device remains in the HOLD mode for reasons of safety. Further operation is performed via IrDA.</p> <p>End communication by pressing <b>meas</b>.</p> <p><b>Exception: Firmware update (must not be interrupted!)</b></p>

Menu item	Remark
	<p><b>Assigning passcodes:</b> In the "SERVICE - CODES" menu you can assign passcodes to DIAG, HOLD, CAL, CONF, and SERVICE modes (Service preset to 5555).</p> <p><b>When you have lost the Service passcode,</b> you have to request an "Ambulance TAN" from the manufacturer specifying the serial number of your device. To enter the "Ambulance TAN", call the Service function and enter passcode 7321. After correct input of the ambulance TAN the device signals "PASS" for 4 sec and resets the Service passcode to 5555.</p>
	<p><b>Reset to factory settings:</b> In the "SERVICE - DEFAULT" menu you can reset the device to factory settings.</p> <p><b>Caution!</b> After a reset to factory setting the device must be reconfigured completely, including the sensor parameters!</p>
	<p><b>Option request:</b> Communicate the serial number and hardware/software version of your device to the manufacturer. These data can be viewed in the Diagnostics/Version menu.</p> <p>The "transaction number" (TAN) you will then receive is only valid for the device with the corresponding serial number.</p> <p><b>Release of options:</b> Options come with a "transaction number" (TAN). This TAN must be entered and confirmed using <b>enter</b> to release the option.</p>

# USP Function

---

According to the "USP" directive (U.S.Pharmacopeia), Section 645 "Water Conductivity" the conductivity of pharmaceutical waters can be monitored online. To do so, the conductivity is measured without temperature compensation and is compared with limit values (see table on next page).

The water is usable when the conductivity is below the USP limit. If the conductivity values are higher, further test steps must be performed according to the directive.

To increase safety, the USP limit value can be reduced in the device. To do so, a factor (%) is specified.

## Configuration steps

- **SNS** menu group:  
When "USP function" has been selected, the measuring range is fixed to 00.00.....99.99  $\mu\text{S}/\text{cm}$ . Temperature compensation is switched off. Temperature is monitored.
- Access **REL** menu group and select USP as limit function.  
Relays 1 and 2 can now be used as USP limit contacts.
- Reduced limit contact **REL1**:  
Enter USP factor (reduced limit, configurable in the range 10%...100%).  
Set contact response for relay 1.  
Set delay time.
- Limit contact **REL2**:  
Set contact response for relay 2.  
Set delay time.

## Temperature/conductivity table as per USP

Temp (°C)	Cond (μS/cm)	Temp (°C)	Cond (μS/cm)
0	0.6	55	2.1
5	0.8	60	2.2
10	0.9	65	2.4
15	1.0	70	2.5
20	1.1	75	2.7
25	1.3	80	2.7
30	1.4	85	2.7
35	1.5	90	2.7
40	1.7	95	2.9
45	1.8	100	3.1
50	1.9		



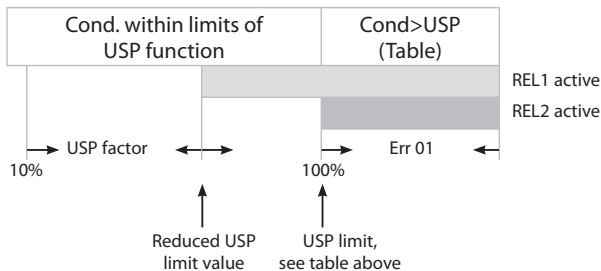

## Limit values for USP function

Limit contact response REL1 and REL2



# Operating States

Operating status	OUT 1	OUT 2	REL1/2 (Limit)	REL1/2 (Control)	ALARM contact	WASH contact	Time out
Measuring							-
Diag							60 s
CAL_SOL Cal solution							No
CAL_CELL Cell constant							No
P_CAL Product cal S1							No
P_CAL Product cal S2							No
CAL RTD Temp adjustm.							20 min
CONF ParSet A							20 min
CONF ParSet B							20 min
CONF Passcodes							20 min
SERVICE MONITOR							20 min
SERVICE OUT 1							20 min
SERVICE OUT 2							20 min
SERVICE RELAIS							20 min
SERVICE CONTROL							20 min
SERVICE IRDA	22 mA						20 min

Operating status	OUT 1	OUT 2	REL1/2 (Limit)	REL1/2 (Control)	ALARM contact	WASH contact	Time out
Cleaning fct							No
HOLD input							No

Explanation:  as configured (Last/Fix or Last/Off)

 active

 manual

# Product Line and Accessories

## Order Code Stratos Pro A 4...

						Channel 1	Channel 2	TAN
<b>Example</b>	A	4	1	1	N	- PH	/ 0	
4-wire / 20...254 V AC/DC	A	4						B,C,E
<b>Communication</b>								
Without (HART retrofittable via TAN)			0					A
HART			1					
<b>Version number</b>								
Version				1				
<b>Approvals</b>								
General Safety					N			
ATEX / IECEX / FM / CSA Zone 2 / Cl 1 Div 2					B			
<b>Meas. channel 1 / Meas. channel 2</b>								
Memosens pH (ORP)				Digital		MSPH	0	
Memosens pH (ORP) / pH (ORP)				Digital		MSPH	MSPH	
Memosens pH (ORP) / Oxy				Digital		MSPH	MSOXY	
Memosens COND				Digital		MSCOND	0	
Memosens COND / COND				Digital		MSCOND	MSCOND	
Memosens Oxy				Digital		MSOxy	0	
Dual COND (2x2-electrode, analog)				Module		CC	0	
pH / ORP value (ISM digital: TAN)				Module		PH	0	F
Cond, 2-/4-electrode				Module		COND	0	
Conductivity, electrodeless				Module		CONDI	0	
Oxygen (ISM digital/Traces: TAN)				Module		OXY	0	D, F
Carbon dioxide (ISM digital: TAN)				Module		CO2	0	F
<b>TAN options</b>								
HART						SW-A001		(A)
Logbook						SW-A002		(B)
Extended logbook (Audit Trail)						SW-A003		(C)
Trace oxygen measurement						SW-A004		(D)
Current input + 2 digital inputs						SW-A005		(E)
ISM digital						SW-A006		(F)
<b>Mounting accessories</b>								
Pipe-mount kit						ZU 0274		
Protective hood						ZU 0737		
Panel-mount kit						ZU 0738		

# Specifications

<b>COND input</b>	Input for Memosens sensors		
<b>Effective range</b>	0.2 $\mu\text{S} \cdot \text{cm}$ ... 1000 $\text{mS} \cdot \text{cm}$		
<b>Display ranges</b>	Conductivity	0.000 ... 9.999 $\mu\text{S}/\text{cm}$ 00.00 ... 99.99 $\mu\text{S}/\text{cm}$ 000.0 ... 999.9 $\mu\text{S}/\text{cm}$ 0000 ... 9999 $\mu\text{S}/\text{cm}$ 0.000 ... 9.999 $\text{mS}/\text{cm}$ 00.00 ... 99.99 $\text{mS}/\text{cm}$ 000.0 ... 999.9 $\text{mS}/\text{cm}$ 0.000 ... 9.999 $\text{S}/\text{cm}$ 00.00 ... 99.99 $\text{S}/\text{cm}$	
	Resistivity	00.00 ... 99.99 $\text{M}\Omega \cdot \text{cm}$	
	Concentration	0.00 ... 9.99 %	
	Salinity	0.0 ... 45.0 ‰	(0 ... 35 °C)
	Response (T90)	Approx. 1 s	
<b>Temp compensation <sup>1)</sup></b> (reference temp 25°C)	(OFF)	Without	
	(LIN)	Linear characteristic 00.00 ... 19.99 %/K	
	(NLF)	Natural waters to EN 27888	
	(NACL)	Ultrapure water with NaCl traces (0 ... 120 °C)	
	(HCL)	Ultrapure water with HCl traces (0 ... 120 °C)	
	(NH3)	Ultrapure water with NH <sub>3</sub> traces (0... 120 °C)	
<b>Concentration determination</b>	-01- NaCl	0.00 ... 9.99% by wt	(0 ... +60°C)
	-02- HCl	0.00 ... 9.99% by wt	(-20 ... +50 °C)
	-03- NaOH	0.00 ... 9.99% by wt	(0 ... +100 °C)
	-04- H <sub>2</sub> SO <sub>4</sub>	0.00 ... 9.99% by wt	(-17 ... +110 °C)
	-05- HNO <sub>3</sub>	0.00 ... 9.99% by wt	(-17 ... +50 °C)
<b>Sensor standardization</b>	Input of cell constant with simultaneous display of selected process variable and temperature		
	Input of conductivity of calibration solution with simultaneous display of cell constant and temperature		
	Product calibration for conductivity		
	Temperature probe adjustment		

# Specifications

Permitted cell constant	00.0050 ... 19.9999 cm <sup>-1</sup>
<b>Sensocheck</b>	Polarization detection and monitoring of cable capacitance
Delay	Approx. 30 s
<b>Sensoface</b>	Provides information on the sensor condition
<b>Sensor monitor</b>	Direct display of measured values from sensor for validation (resistance/temperature)
<b>USP function</b>	Water monitoring in the pharmaceutical industry (USP) with additional limit value (%) Output via relay contact or HART
<b>Temperature input *</b>	Pt100/Pt1000/NTC 30 kΩ/NTC 8.55 kΩ (Betatherm) 3-wire connection, adjustable
Measuring range	Pt 100/Pt 1000      -50 ... +200 °C / -58 ... +392 °F NTC 30 kΩ            -20 ... +150 °C / -4 ... +302 °F NTC 8.55 kΩ        -10 ... +130 °C / -4 ... +266 °F
Resolution	0.1 °C / 0.1 °F
Meas. error <sup>1,2,3)</sup>	< 0.5 K (< 1 K for Pt 100; <1K for NTC >100°C)
<b>I input (TAN)</b>	Current input 0/4 ... 20 mA / 50 Ω for external temperature signal
Start/end of scale	Configurable -50 ... +200 °C / -58 ... +392 °F
Characteristic	Linear
Measurement error <sup>1,3)</sup>	< 1% current value + 0.1 mA
<b>HOLD input</b>	Galvanically separated (OPTO coupler)
Function	Switches device to HOLD mode
Switching voltage	0 ... 2 V (AC/DC)      HOLD inactive 10 ... 30 V (AC/DC)    HOLD active
<b>CONTROL input</b>	Galvanically separated (OPTO coupler)
Function	Selecting parameter set A/B
Switching voltage	0 ... 2 V (AC/DC)      Parameter set A 10 ... 30 V (AC/DC)    Parameter set B

<b>Output 1</b>	0/4 ... 20 mA, max. 10 V, floating (galv. connected to output 2)	
Process variable <sup>*</sup>	Conductivity, resistivity, concentration, salinity, or temperature	
Characteristic	Linear or logarithmic	
Overrange <sup>*</sup>	22 mA in the case of error messages	
Output filter <sup>*</sup>	PT <sub>1</sub> filter, time constant 0 ... 120 s	
Measurement error <sup>1)</sup>	< 0.25 % current value + 0.025 mA	
Start/end of scale <sup>*</sup>	Configurable within selected range	
Minimum span	LIN	5% of selected range
	LOG	1 decade
<b>Output 2</b>	0/4 ... 20 mA, max. 10 V, floating (galv. connected to output 1)	
Process variable <sup>*</sup>	Conductivity, resistivity, concentration, salinity, or temperature	
Characteristic	Linear or logarithmic	
Overrange <sup>*</sup>	22 mA in the case of error messages	
Output filter <sup>*</sup>	PT <sub>1</sub> filter, time constant 0 ... 120 s	
Measurement error <sup>1)</sup>	< 0.25 % current value + 0.025 mA	
Start/end of scale <sup>*</sup>	Configurable within selected range	
Minimum span	LIN	5% of selected range
	LOG	1 decade
<b>Alarm contact</b>	Relay contact, floating	
Contact ratings	AC	< 250 V / < 3 A / < 750 VA
	DC	< 30 V / < 3 A / < 90 W
Contact response	N/C (fail-safe type)	
Response delay	0000 ... 0600 sec	
<b>Wash contact</b>	Relay contact, floating	
	For controlling a cleaning system	
Contact ratings	AC	< 250 V / < 3 A / < 750 VA
	DC	< 30 V / < 3 A / < 90 W

# Specifications

Contact response*	N/C or N/O	
Interval*	000.0 ... 999.9 h (000.0 h = cleaning function switched off)	
Cleaning time*	0000 ... 1999 s	
or		
Parameter set A/B	For signaling parameter set A/B	
Contact ratings	AC	< 250 V / < 3 A / < 750 VA
	DC	< 30 V / < 3 A / < 90 W
Contact response*	Contact open:	Parameter set A active
	Contact closed:	Parameter set B active
Limit values Rel1/Rel2	Rel1/Rel2 contacts, floating, but inter-connected	
Contact ratings	AC	< 250 V / < 3 A / < 750 VA
	DC	< 30 V / < 3 A / < 90 W
Contact response*	N/C or N/O	
Response delay*	0000 ... 9999 s	
Switching points*	As desired within range	
Hysteresis*	User-defined	
PID process controller	Output via Rel1/Rel2 relay contacts (see limit values)	
Setpoint specification*	Within selected range	
Neutral zone*	Max. 50 % of selected range	
Proportional action*	Controller gain	Kp: 0010 ... 9999 %
Integral action*	Reset time	Tr: 0000 ... 9999 s (0000 s = no integral action)
Derivative action*	Rate time	Td: 0000 ... 9999 s (0000 s = no derivative action)
Controller type*	Pulse length controller or pulse frequency controller	
Pulse period*	0001 ... 0600 s, min. ON time 0.5 s (pulse length controller)	
Max. pulse frequency*	0001 ... 0180 min <sup>-1</sup> (pulse frequency controller)	

<b>Real-time clock</b>	Different time and date formats selectable
Power reserve	> 5 days
<b>Display</b>	LC display, 7-segment with icons
Main display	Character height approx. 22 mm, unit symbols approx. 14 mm
Secondary display	Character height approx. 10 mm
Text line	14 characters, 14 segments
Sensoface	3 status indicators (friendly, neutral, sad face)
Mode indicators	meas, cal, conf, diag Further icons for configuration and messages
Alarm indication	Display blinks, red backlighting
<b>Keypad</b>	Keys: meas, info, 4 cursor keys, enter
<b>HART communication</b>	HART version 6 Digital communication by FSK modulation of output current 1 Device identification, measured values, status and messages, parameter setting, calibration, records
Conditions	Output current $\geq 3.8$ mA and load resistance $\geq 250 \Omega$
<b>IrDA interface</b>	Infrared interface for firmware update
<b>FDA 21 CFR Part 11</b>	Access control by editable passcodes Logbook entry and flag via HART in the case of configuration changes Message and logbook entry when enclosure is opened
<b>Diagnostics functions</b>	
Calibration data	Calibration date, cell constant
Device self-test	Displaytest, automatic memory test (RAM, FLASH, EEPROM), module test
Logbook	100 events with date and time
Extended logbook (TAN)	Audit Trail: 200 events with date and time

# Specifications

<b>Service functions</b>	
Sensor monitor	Display of direct sensor signals
Current source	Current specifiable for output 1 and 2 (00.00 ... 22.00 mA)
Relay test	Manual control of the four switching contacts
Manual controller	Controller output entered directly (start of control process)
IrDA	Activating the IrDA function
Passcodes	Assigning passcodes for menu access
Factory setting	Resetting all parameters to factory setting
TAN	Enabling optionally available additional functions
<b>Data retention</b>	Parameters, calibration data, logbook > 10 years (EEPROM)
<b>EMC</b>	EN 61326-1 (General Requirements)
Emitted interference	Class B (residential area)
Immunity to interference	Industry EN 61326-2-3
<b>Explosion protection</b>	USA: FM Cl I Div 2 / Zone 2
Stratos Pro A4...B MSCOND (pending)	Canada: CSA Cl I Div 2 / Zone 2
<b>Power supply</b>	24 (-15%) ... 230 (+10%) V AC/DC <sup>0</sup> ; < 12 VA, < 4 W AC: 45 ... 65 Hz Overvoltage category II, protection class II
<b>Nominal operating conditions</b>	
Ambient temperature	-20 ... +55 °C
Transport/Storage temperature	-20 ... +70 °C
Relative humidity	10 ... 95% not condensing
Power supply	24 (-15%) ... 230 (+10%) V AC/DC (DC ≤ 80V)
Frequency for AC	45 ... 65 Hz

Enclosure	Molded enclosure made of PBT/PC, glass reinforced
Fastening	Wall, pipe/post, or panel mounting
Color	Gray, RAL 7001
Ingress protection	IP 67
Flammability	UL 94 V-0
Dimensions	148 mm x 148 mm
Control panel cutout	138 mm x 138 mm to DIN 43 700
Weight	Approx. 1200 g
Cable glands	3 knockouts for M20 x 1.5 cable glands 2 knockouts for NPT 1/2" or rigid metallic conduit
Connections	Terminals, conductor cross section max. 2.5 mm <sup>2</sup>
* User-defined	1) Acc. to EN 60746, at nominal operating conditions
2) ± 1 count	3) Plus sensor error
4) DC ≤ 80 V	

# Calibration Solutions

---

## Potassium Chloride Solutions

(Conductivity in mS/cm)

Temperature [°C]	Concentration <sup>1</sup>		
	0.01 mol/l	0.1 mol/l	1 mol/l
0	0.776	7.15	65.41
5	0.896	8.22	74.14
10	1.020	9.33	83.19
15	1.147	10.48	92.52
16	1.173	10.72	94.41
17	1.199	10.95	96.31
18	1.225	11.19	98.22
19	1.251	11.43	100.14
20	1.278	11.67	102.07
21	1.305	11.91	104.00
22	1.332	12.15	105.94
23	1.359	12.39	107.89
24	1.386	12.64	109.84
25	1.413	12.88	111.80
26	1.441	13.13	113.77
27	1.468	13.37	115.74
28	1.496	13.62	
29	1.524	13.87	
30	1.552	14.12	
31	1.581	14.37	
32	1.609	14.62	
33	1.638	14.88	
34	1.667	15.13	
35	1.696	15.39	
36		15.64	

---

<sup>1</sup> Data source: K. H. Hellwege (Editor), H. Landolt, R. Börnstein: Zahlenwerte und Funktionen ..., volume 2, part. volume 6

---

## Sodium Chloride Solutions

(Conductivity in mS/cm)

Temperature	Concentration		
[°C]	0.01 mol/l <sup>1)</sup>	0,1 mol/l <sup>1)</sup>	Saturated <sup>2)</sup>
0	0.631	5.786	134.5
1	0.651	5.965	138.6
2	0.671	6.145	142.7
3	0.692	6.327	146.9
4	0.712	6.510	151.2
5	0.733	6.695	155.5
6	0.754	6.881	159.9
7	0.775	7.068	164.3
8	0.796	7.257	168.8
9	0.818	7.447	173.4
10	0.839	7.638	177.9
11	0.861	7.831	182.6
12	0.883	8.025	187.2
13	0.905	8.221	191.9
14	0.927	8.418	196.7
15	0.950	8.617	201.5
16	0.972	8.816	206.3
17	0.995	9.018	211.2
18	1.018	9.221	216.1
19	1.041	9.425	221.0
20	1.064	9.631	226.0
21	1.087	9.838	231.0
22	1.111	10.047	236.1
23	1.135	10.258	241.1
24	1.159	10.469	246.2
25	1.183	10.683	251.3
26	1.207	10.898	256.5
27	1.232	11.114	261.6
28	1.256	11.332	266.9
29	1.281	11.552	272.1
30	1.306	11.773	277.4
31	1.331	11.995	282.7
32	1.357	12.220	288.0
33	1.382	12.445	293.3
34	1.408	12.673	298.7
35	1.434	12.902	304.1
36	1.460	13.132	309.5

1 Data source: Test solutions calculated according to DIN IEC 746-3

2 Data source: K. H. Hellwege (Editor), H. Landolt, R. Börnstein: Zahlenwerte und Funktionen ..., volume 2, part. volume 6

# Concentration Curves

## -01- Sodium chloride solution NaCl

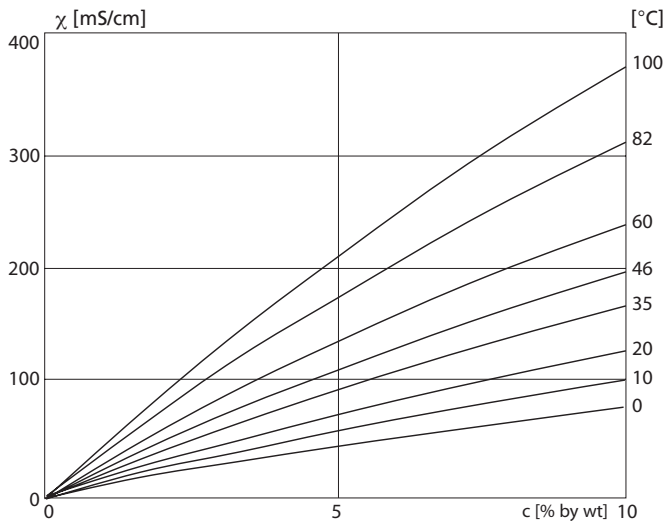

Conductivity versus substance concentration and process temperature for sodium chloride solution (NaCl)

## -02- Hydrochloric acid HCl

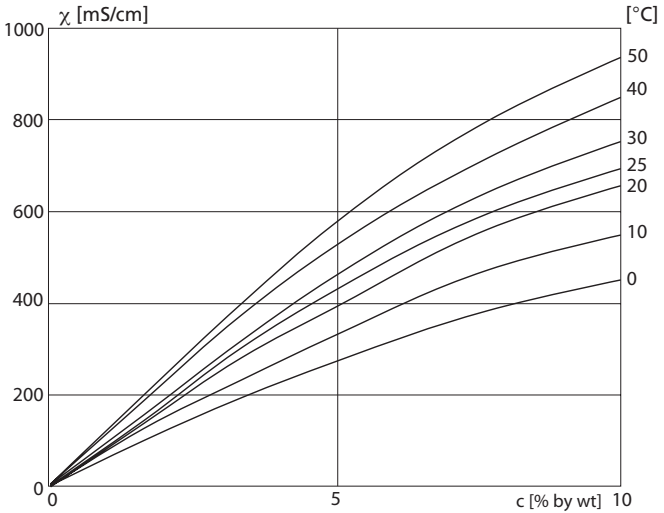

Conductivity versus substance concentration and process temperature for hydrochloric acid (HCl)

Source: Haase/Sauermann/Dücker; Z. phys. Chem. New Edition, Vol. 47 (1965)

# Concentration Curves

## -03- Sodium hydroxide solution NaOH

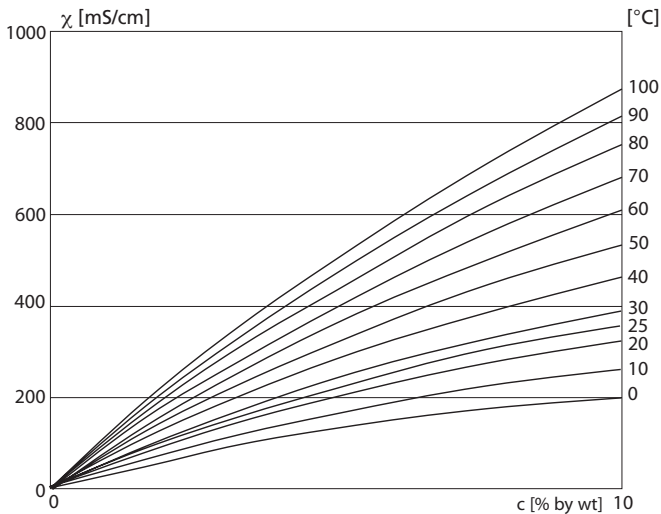

Conductivity versus substance concentration and process temperature for sodium hydroxide solution (NaOH)

## -04- Sulfuric acid $H_2SO_4$

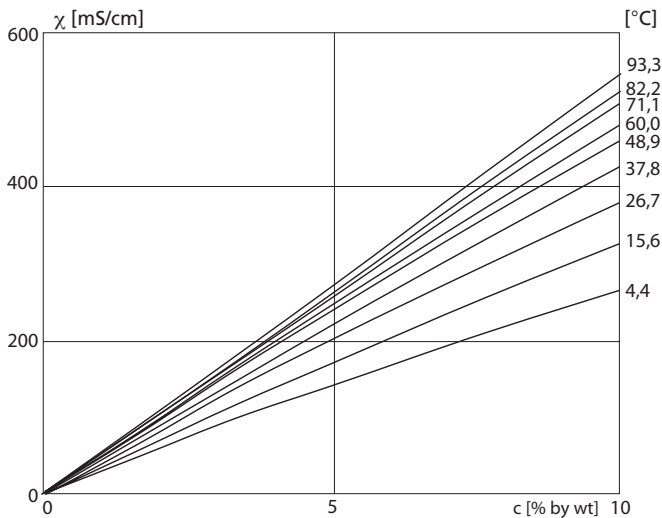

Conductivity versus substance concentration and process temperature for sulfuric acid ( $H_2SO_4$ )

Source: Darling; Journal of Chemical and Engineering Data; Vol.9 No.3, July 1964

# Concentration Curves

---

## -05- Nitric acid $\text{HNO}_3$

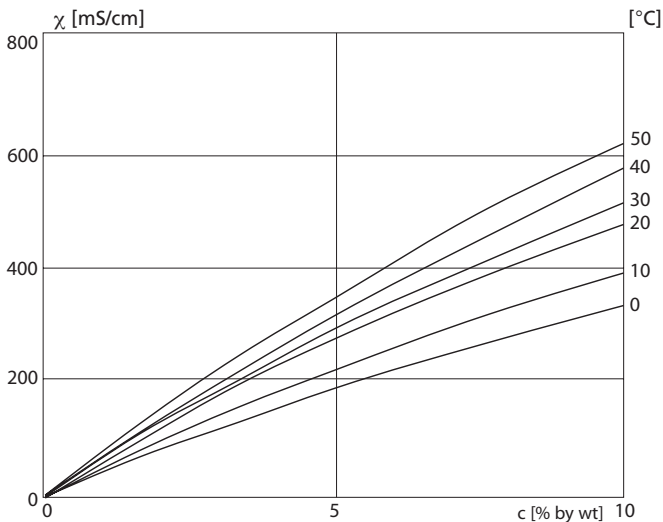

Conductivity versus substance concentration and process temperature for nitric acid ( $\text{HNO}_3$ )

Source: Haase/Sauermann/Dücker; Z. phys. Chem. New Edition, Vol. 47 (1965)

## Alarm condition:

- The display backlighting turns **red**
- The alarm icon  is displayed
- The complete measured-value display blinks
- “**ERR xxx**” is displayed in the lower menu line

Press the [**info**] key to view a short error text:

- The error text appears in the lower menu line
- The main display reads “**InFo**”.

## Parameter errors:

Configuration data such as current range, limit values, etc are checked during the input.

If they are out of range,

- “**ERR xxx**” is displayed for 3 sec,
- the display backlighting flashes red,
- the respective maximum or minimum value is shown,
- input must be repeated.

If a faulty parameter arrives through the interface (IrDA, HART),

- an error message will be displayed: “**ERR 100...199**”
- the faulty parameter can be localized by pressing the [**info**] key

## Calibration errors:

If errors occur during calibration,

- an error message will be displayed
- calibration will be restarted

## Sensoface:

If the Sensoface becomes sad,

- the display backlighting will turn purple
- the cause can be seen by pressing the **info** key
- the calibration data can be seen in the Diagnostics menu

# Error Messages

<b>Error</b>	<b>Info text</b> (is displayed in case of fault when the Info key is pressed)	<b>Problem</b> <b>Possible causes</b>
<b>ERR 99</b>	DEVICE FAILURE	<b>Error in factory settings</b> EEPROM or RAM defective This error message only occurs in the case of a total defect. The device must be repaired and recalibrated at the factory.
<b>ERR 98</b>	CONFIGURATION ERROR	<b>Error in configuration or calibration data</b> Memory error in device program Configuration or calibration data defective; completely reconfigure and recalibrate the device.
<b>ERR 97</b>	NO MODULE INSTALLED	<b>No module</b> Please have the module replaced in the factory.
<b>ERR 96</b>	WRONG MODULE	<b>Wrong module</b> Please have the module replaced in the factory.
<b>ERR 95</b>	SYSTEM ERROR	<b>System error</b> Restart required. If error still persists, send in the device for repair.
<b>ERR 100</b>	INVALID SPAN OUT1	Span Out1 configuration error
<b>ERR 101</b>	INVALID SPAN OUT2	Span Out2 configuration error
<b>ERR 104</b>	INVALID PARAMETER CONTROLLER	Controller configuration error
<b>ERR 105</b>	INVALID SPAN I-INPUT	I-Input configuration error

<b>Error</b>	<b>Info text</b> (is displayed in case of fault when the Info key is pressed)	<b>Problem</b> <b>Possible causes</b>
<b>ERR 10</b>	CONDUCTANCE TOO HIGH	<b>Measuring range of conductance exceeded</b> > 3500 mS
<b>ERR 11</b>	CONDUCTIVITY RANGE  CONCENTRATION RANGE  SALINITY RANGE	<b>Display range violation</b>  Cond > 1999 mS/cm > 99.99 S/m < 1 ohm * cm  Conc > 9.99 %  SAL > 45.0 ‰
<b>ERR 13</b>	TEMPERATURE RANGE	<b>Temperature range violation</b>
<b>ERR 15</b>	SENSOCHECK	<b>Sensocheck</b>
<b>ERR 60</b>	OUTPUT LOAD	<b>Load error</b>
<b>ERR 61</b>	OUTPUT 1 TOO LOW	<b>Output current 1</b> < 0 (3.8) mA
<b>ERR 62</b>	OUTPUT 1 TOO HIGH	<b>Output current 1</b> > 20.5 mA
<b>ERR 63</b>	OUTPUT 2 TOO LOW	<b>Output current 2</b> < 0 (3.8) mA
<b>ERR 64</b>	OUTPUT 2 TOO HIGH	<b>Output current 2</b> > 20.5 mA

# Sensoface

---

(Sensocheck must have been activated during configuration.)



The smiley in the display (Sensoface) alerts to sensor problems (defective sensor, sensor wear, defective cable, maintenance request). The permitted calibration ranges and the conditions



for a friendly, neutral, or sad Sensoface are summarized in the following table. Additional icons refer to the error cause.



## **Sensocheck (not for Memosens)**

Continuously monitors the sensor polarization and the sensor cable capacitance. Critical values make the Sensoface “sad” and the corresponding icon blinks:







The Sensocheck message is also output as error message Err 15. The alarm contact is active, the display backlighting turns red, output current 1 is set to 22 mA (when configured correspondingly). Sensocheck can be switched off during configuration (then Sensoface is also disabled).

### **Exception:**

After a calibration a smiley is always displayed for confirmation.

### **Please note:**

The worsening of a Sensoface criterion leads to the devaluation of the Sensoface indicator (Smiley becomes “sad”). An improvement of the Sensoface indicator can only take place after calibration or removal of the sensor defect.

Display	Problem	Status
	Sensor defect	 <p>– Not for Memosens – Wrong or defective sensor, significant polarization of sensor, or excessive cable capacitance (see also error message Err 15).</p>
	Temperature	 <p>Temperature outside range for TC, conc, sal</p>

# FDA 21 CFR Part 11

---

## **Conformity with FDA 21 CFR Part 11**

In their directive “Title 21 Code of Federal Regulations, 21 CFR Part 11, Electronic Records; Electronic Signatures” the US American health agency FDA (Food and Drug Administration) regulates the production and processing of electronic documents for pharmaceutical development and production. This results in requirements for measuring devices used for corresponding applications. The following features ensure that the measuring devices of this Series meet the demands of FDA 21 CFR Part 11:

### **Electronic Signature – Passcodes**

Access to the device functions is regulated and limited by individually adjustable codes – “Passcodes” (see SERVICE). This prevents unauthorized modification of device settings or manipulation of the measurement results. Appropriate use of these passcodes makes them suitable as electronic signature.

### **Audit Trail**

Every (manual) change of device settings can be automatically documented. Each change is tagged with a “Configuration Change Flag”, which can be interrogated and documented using HART communication. Altered device settings or parameters can also be retrieved and documented using HART communication.

### **Extended logbook**

Audit Trail also records function activations (CAL, CONFIG, SERVICE), some Sensoface messages (cal timer, wear), and opening of the enclosure.

## A

- Access codes 128, 140
- Accessories 108
- Alarm 29
  - Alarm contact 61
- Alarm settings 60
- Ambulance TAN 103
- Application in hazardous locations 15
- Approvals for application in hazardous locations 9, 114
- Assembly 11
- Audit Trail 128
- Autorange 49

## B

- Backlighting 23

## C

- Calibration 26, 85
  - Calibration by entry of cell constant 88
  - Calibration error 123
  - Calibration with calibration solution 86
  - Product calibration 89
- Calibration data 96
- Calibration error 123
- Calibration mode 85
- Calibration solutions 116
- CD-ROM 3
- CIP / SIP 47
- Compulsory marking 9, 16
- Concentration curves
  - 01- Sodium chloride solution NaCl 118
  - 02- Hydrochloric acid HCl 119
  - 03- Sodium hydroxide solution NaOH 120
  - 04- Sulfuric acid H<sub>2</sub>SO<sub>4</sub> 121
  - 05- Nitric acid HNO<sub>3</sub> 122
- Concentration measurement 43

- Configuration 26
  - Controller 72
  - Current output 1 48
  - Current output 2 54
  - Individual configuration data 38
  - Limit function 62
  - Menu groups 31
  - Menu structure 30
  - Overview 33
  - Sensor 42
  - Tag number 78
  - Temperature compensation 56
  - Time and date 78
  - WASH contact 76
- Controller 69
  - Configuration 72
  - Controller equations 70
  - Controller functions 69
  - Controller test 102
  - Controller type 73
  - Manual specification of controller output 102
  - Neutral zone 75
  - Pulse frequency 73
  - Pulse length 73
  - Setpoint 73
- Controller characteristic 69

## D

- Date 79
  - Display 92
- Device self-test 97
- Device type, display 99
- Diagnostics 26, 95
  - Calibration data 96
  - Device self-test 97
  - Logbook 98
  - Sensor monitor 98
  - Version 99

- Digital sensors **80**
  - Connection **81**
  - Sensor replacement **82**
- Dimensions **12**
- Display **23**
  - Display data in Diagnostics mode **95**
  - Display test **97**
- Display backlighting **23**
- Disposal **2**
- Documentation **3**

**E**

- EEPROM test **97**
- Electrical installation **9**
- Electronic Signature **128**
- Enclosure **12**
- Enclosure components **11**
- Entering values **25**
- Error handling **123**
- Error messages **124**
- Explosion protection **114**
- Extended logbook **128**

**F**

- FDA 21 CFR Part 11 **128**
- FLASH test **97**

**H**

- HOLD **26, 28**
  - End **28**
  - External activation of HOLD **29**
  - Manual activation of HOLD **29**
  - Output signal during HOLD **28, 53**
  - Output signal response **28**
- Hysteresis **65, 67**

## I

- Info text 124
- Installation 15
  - Safety information 9
- Installation instructions 15
- Intended use 7
- IrDA communication 102

## K

- Keypad 22

## L

- Limit 1 62
- Limit 2 66
- Logbook 98

## M

- Measurement 92
- Measuring 24
- Memosens 80
  - Connection via RS-485 19
  - Wiring example 18
- Menu structure 27
  - Configuration 30
- Module test 97
- Mounting plan 12

## O

- Operating modes 26
- Operating mode, selection 25
- Operating states 106
- Option request: Conditions 99
- Options 103, 108
- Order code 108
- Output current, fixed value 101
- Output filter 50
- Output signal during HOLD 28, 53
- Overview 10

**P**

- Package contents 3, 11
- Panel mounting 14
- Parameter error 123
- Parameter set A/B 31
  - Display 92
  - Display via WASH contact 32
  - Manual selection 32
- Passcodes 128, 140
  - Setting 103
- PFC 71
- Pipe mounting 13
- PLC 71
- Point of measurement (TAG) 79
- Power supply 17
- Process variable 49
- Product calibration 89
- Product line 108
- Protective hood 13
- Protective wiring 20
- Pulse frequency controller (PFC) 71
- Pulse length controller (PLC) 71

**R**

- RAM test 97
- Rating plates 16
- Registered trademarks 139
- Relay 1 62
- Relay 2 66
- Relay test 101
- Release of options 103
- Reset to factory settings 103
- Return of products under warranty 2

**S**

- Safety information 7, 8
- Safety instructions 3
- Selection menu 25
- Sensocheck 60, 126

# Index

---

Sensoface 123, 126  
Sensor monitor 98, 101  
Sensor type selection 42, 44  
Serial number, display 99  
Service 26, 100

- Controller test 102
- Factory setting 103
- IrDA communication 102
- Passcodes 103
- Relay test 101
- Releasing options 103
- Sensor monitor 101
- Specifying current outputs 101

Service passcode lost 103  
Signal colors 23  
Signal lines 17  
Software version, display 99  
Specifications 109  
Start-up 8

## T

TAG 79  
TAN options 103, 108  
Temperature compensation 56, 59  
Temperature probe 91  
Terminal assignments 16  
Terminals 9, 15  
Time 79

- Display 92

Time averaging filter 51  
Trademarks 139

## U

User interface 22  
USP function 104

## **W**

Warranty 2

WASH contact

    Configuration 76

    Signaling parameter set 32

Wiring 17

Wiring example 18





---

## Trademarks

---

The following names are registered trademarks. For practical reasons they are shown without trademark symbol in this manual.

Stratos®

Sensocheck®

Sensoface®

Calimatic®

GainCheck®

InPro® is a registered trademark of Mettler-Toledo.

Memosens® is a registered trademark of Endress+Hauser Conducta GmbH and Knick Elektronische Messgeräte GmbH & Co. KG.

HART® is a registered trademark of the HART Communication Foundation.

# Passcodes

In the SERVICE – CODES menu you can assign passcodes to protect the access to certain functions.

Operating mode	Passcode
Service (SERVICE)	5555
Diagnostics (DIAG)	
HOLD mode	
Calibration (CAL)	
Configuration (CONF)	

---

## Knick Elektronische Messgeräte GmbH & Co. KG

P.O. Box 37 04 15  
D-14134 Berlin

Tel: +49 (0)30 - 801 91 - 0  
Fax: +49 (0)30 - 801 91 - 200  
Internet: <http://www.knick.de>  
[knick@knick.de](mailto:knick@knick.de)