

Stratos[®] Pro A4... MSPH

Instruction Manual

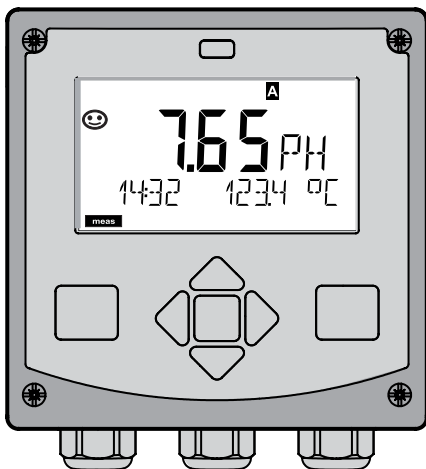

Latest Product Information:

www.knick.de



77187

Knick >

Warranty

Warranty

Defects occurring within 3 years from delivery date shall be remedied free of charge at our plant (carriage and insurance paid by sender).
Sensors, fittings, and accessories: 1 year.

Subject to change without notice.

Return of Products Under Warranty

Please contact our Service Team before returning a defective device. Ship the cleaned device to the address you have been given. If the device has been in contact with process fluids, it must be decontaminated/disinfected before shipment. In that case, please attach a corresponding certificate, for the health and safety of our service personnel.

Disposal

Please observe the applicable local or national regulations concerning the disposal of “waste electrical and electronic equipment”.



CD-ROM

Complete documentation:

- Instruction manuals
- Safety instructions
- Short instructions



Safety Information

In official EU languages and others.

- ATEX / IECEX / FM / CSA
- EC Declarations of Conformity



Short Instructions

In German, English, French, Russian, Spanish, Portuguese, Swedish, and Dutch. More languages on CD-ROM and on our website: www.knick.de

- Installation and commissioning
- Operation
- Menu structure
- Calibration
- Error messages and recommended actions

Specific Test Report

Contents

Documents Supplied	3
Introduction	7
Intended Use.....	7
Safety Information	8
Safety Precautions for Installation	9
Registered Trademarks	9
Overview of Stratos Pro A4... MSPH.....	10
Assembly	11
Package Contents.....	11
Mounting Plan, Dimensions	12
Pipe Mounting, Protective Hood	13
Panel Mounting.....	14
Installation	15
Installation Instructions	15
Rating Plates / Terminal Assignments.....	16
Power Supply, Signal Lines	17
Sensor Connection	18
Wiring Examples	19
Protective Wiring of Relay Contacts	22
User Interface, Keypad	24
Display	25
Signal Colors (Display Backlighting).....	25
Measuring Mode.....	26
Selecting the Mode / Entering Values	27
Operating Modes.....	28
Menu Structure of Modes and Functions.....	29
HOLD Mode	30
Alarm.....	31
Configuration	32
Menu Structure of Configuration	32

Parameter Set Selection	34
Parameter Set A/B.....	34
Configuration	35
Configuration (Original for Copy).....	39
Sensor	42
Current Output 1	50
Current Output 2	56
Temperature Compensation	58
Alarm.....	60
Limit Function.....	62
Pulse Length / Pulse Frequency Controller.....	71
Controller	72
WASH Contact	76
Time and Date	78
Tag Number	78
Digital Sensors	80
Operation	80
Connecting a Digital Sensor.....	81
Sensor Replacement	82
Calibration	84
Selecting a Calibration Mode	85
Zero Adjustment (ISFET).....	86
Automatic Calibration (Calimatic)	88
Manual Calibration with Buffer Entry	90
Data Entry of Premeasured Sensors.....	92
Product Calibration (pH).....	94
ORP (Redox) Calibration	96
Temp Probe Adjustment.....	98
Measurement	99
Diagnostics	101
Service	106
Operating States	110

Contents

Product Line and Accessories	112
Specifications	113
Buffer Tables	120
-U1- Specifiable Buffer Set	129
Error Handling.....	132
Error Messages.....	133
Sensoface	136
FDA 21 CFR Part 11	139
Electronic Signature – Passcodes	139
Audit Trail	139
Index	140
Passcodes	148

Intended Use

The Stratos Pro A4... MSPH is used for pH/mV, ORP, and temperature measurement in industry, environment, food processing, and sewage treatment.

The sturdy molded enclosure can be fixed into a control panel or mounted on a wall or at a post. The protective hood, which is available as accessory, provides additional protection against direct weather exposure and mechanical damage.

The device has been designed for digital sensors.

Plain-text messages in a large, backlit display allow intuitive operation. The colored display backlighting signals alarm messages (red) or HOLD mode (orange).

The "Sensocheck" automatic monitoring of glass and reference electrode and the "Sensoface" function for clear indication of the sensor condition provide excellent diagnostics. The internal logbook (TAN SW-A002) can handle up to 100 entries – up to 200 with AuditTrail (TAN SW-A003).

The device provides two parameter sets which can be switched manually or via a control input for different process adaptations or different process conditions (e.g. beer and CIP).

Password protection for granting access rights during operation can be configured.

Two floating, digital control inputs ("Hold" and "Control") are available for external control.

The internal PID process controller can be configured as pulse length or pulse frequency controller.

The device provides two current outputs (for transmission of measured value and temperature, for example) and four floating relay contacts. A time-controlled cleaning function can be configured.

Current is provided through a universal power supply 24 ... 230 V AC/DC, AC: 45 ... 65 Hz.

Approvals for Measurement in Hazardous Locations:

Stratos Pro A4...B MSPH: acc. to FM and CSA in Class I Div 2 / Zone 2

Safety Information

Safety information –

Be sure to read and observe the following instructions!

The device has been manufactured using state of the art technology and it complies with applicable safety regulations.

When operating the device, certain conditions may nevertheless lead to danger for the operator or damage to the device.

See also separate document:

- “Safety Instructions”.
(EC Declaration of Conformity, FM, CSA Certificates)



CAUTION!

Commissioning must only be performed by trained personnel authorized by the operating company! Whenever it is likely that protection has been impaired, the device shall be made inoperative and secured against unintended operation.

The protection is likely to be impaired if, for example:

- the device shows visible damage
- the device fails to perform the intended measurements
- after prolonged storage at temperatures above 70°C
- after severe transport stresses

Before recommissioning the device, a professional routine test must be performed. This test must be carried out at the manufacturer's factory.

Please note:

Before commissioning it must be proved that the device may be connected with other equipment.

Safety Precautions for Installation

- The electrical installation shall conform to the national regulations for electrical installations and/or other applicable national or local codes or regulations.
- The power supply shall be disconnectable from the device by a two-poled circuit breaker.
- Switch and circuit breaker shall be located in close proximity to the equipment and be easily accessible by the OPERATOR. They shall be marked as disconnect switch for the device.
- Be sure to disconnect the mains supply and any relay contacts which are connected to separate current sources before starting maintenance operations.

Approvals for Application in Hazardous Locations

Stratos Pro A4...B MSPH: acc. to FM and CSA in Class I Div 2 / Zone 2

Terminals:

Screw terminal, suitable for single wires / flexible leads up to 2.5 mm² (AWG 14).

Recommended torque for the terminal screws: 0,5 ... 0,6 Nm.

Further Information on Installation in Hazardous Locations:

See also separate "Safety Instructions" document.

Registered Trademarks

The following names are registered trademarks. For practical reasons they are shown without trademark symbol in this manual.

Stratos[®]

Sensocheck[®]

Sensoface[®]

Calimatic[®]

GainCheck[®]

InPro[®] is a registered trademark of Mettler-Toledo.

HART[®] is a registered trademark of the HART Communication Foundation.

Overview

Overview of Stratos Pro A4... MSPH

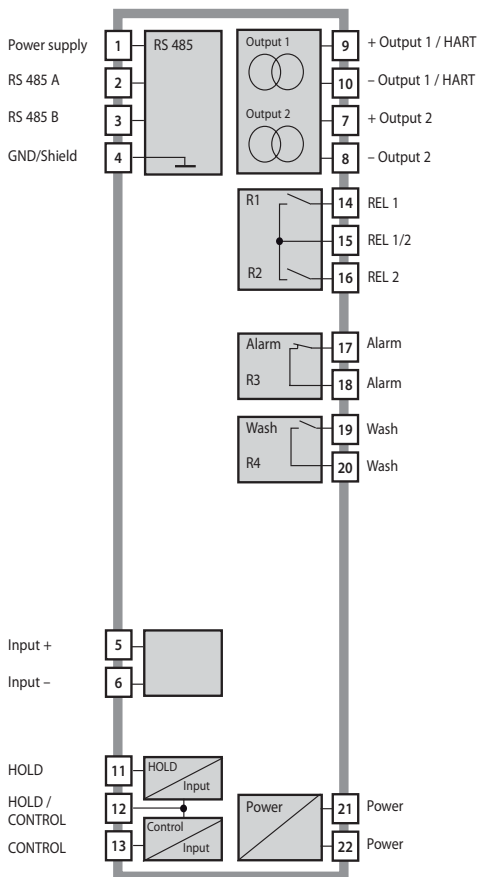

Package Contents

Check the shipment for transport damage and completeness!

The package should contain:

- Front unit, rear unit, bag containing small parts
- Specific test report
- Documentation (cf Pg 3)
- CD-ROM

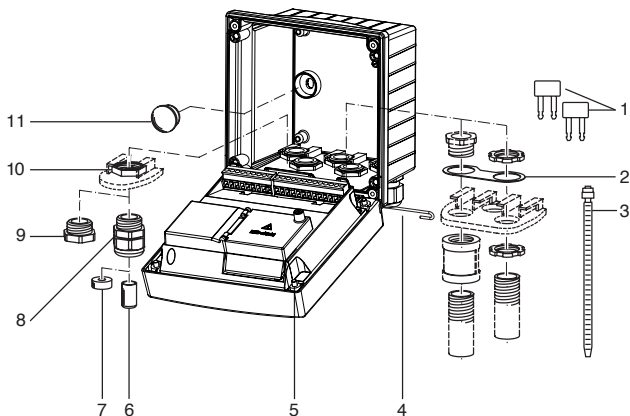

Fig.: Assembling the enclosure

- | | |
|---|--|
| 1) Jumper (3 x) | 6) Sealing insert (1 x) |
| 2) Washer (1 x), for conduit mounting: Place washer between enclosure and nut | 7) Rubber reducer (1 x) |
| 3) Cable tie (3 x) | 8) Cable gland (3 x) |
| 4) Hinge pin (1 x), insertable from either side | 9) Filler plug (3 x) |
| 5) Enclosure screw (4 x) | 10) Hexagon nut (5 x) |
| | 11) Sealing plug (2 x), for sealing in case of wall mounting |

Mounting Plan, Dimensions

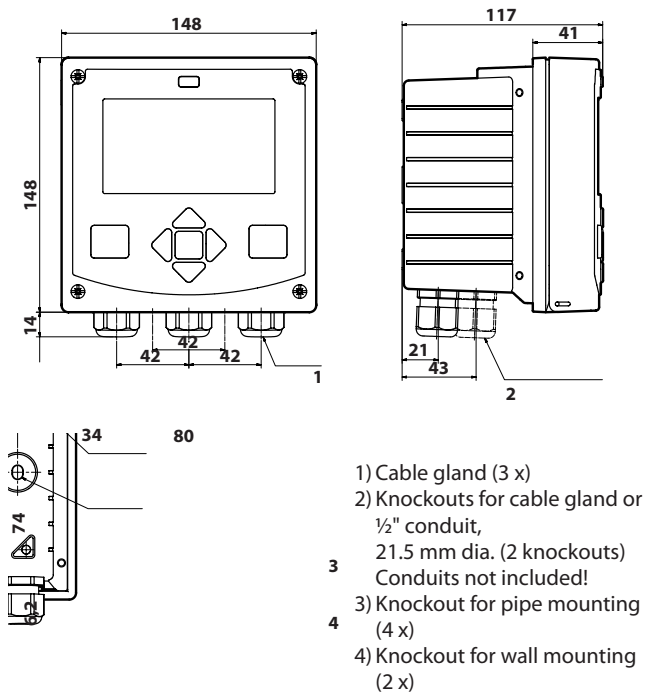
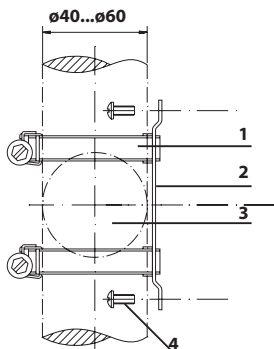

Fig.: Mounting plan (All dimensions in mm!)

Pipe Mounting, Protective Hood



- 1) Hose clamp with worm gear drive to DIN 3017 (2 x)
- 2) Pipe-mount plate (1 x)
- 3) For vertical or horizontal posts or pipes
- 4) Self-tapping screw (4 x)

Fig.: ZU 0274 pipe-mount kit (All dimensions in mm!)

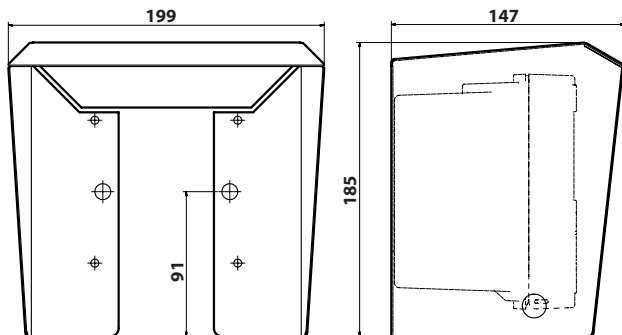

Fig.: ZU 0737 protective hood for wall and pipe mounting
(All dimensions in mm!)

Panel Mounting

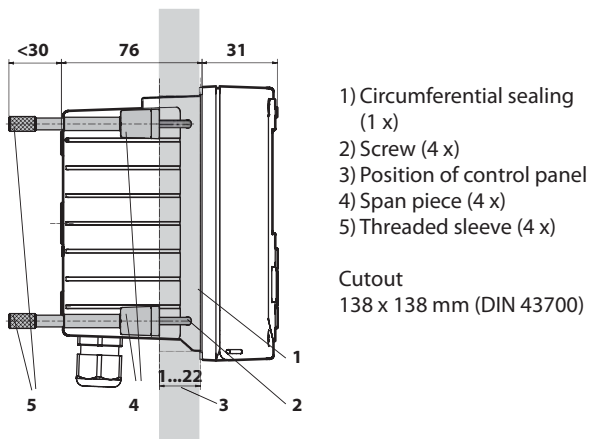

Fig.: ZU 0738 panel-mount kit (All dimensions in mm!)

Installation Instructions

- Installation of the device must be carried out by trained experts in accordance with this instruction manual and as per applicable local and national codes.
- Be sure to observe the technical specifications and input ratings during installation!
- Be sure not to notch the conductor when stripping the insulation!
- Before connecting the device to the power supply, make sure that its voltage lies within the range 24 to 230 V AC/DC!
- The supplied current must be galvanically isolated. If not, connect an isolator module.
- All parameters must be set by a system administrator prior to commissioning!

Terminals:

suitable for single wires / flexible leads up to 2.5 mm² (AWG 14)



Additional safety precautions have to be taken for operation in hazardous locations FM, CSA Cl. I Div 2 / Zone 2!
(See separate “Safety Instructions” document.)

Rating Plates / Terminal Assignments

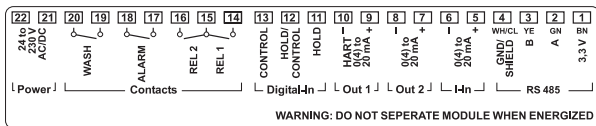

Fig.: Terminal assignments of Stratos Pro A4...

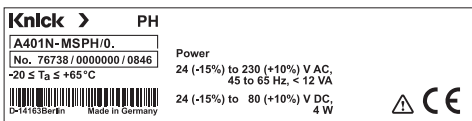

Fig.: Stratos Pro A401N-MSPH rating plate at bottom of front

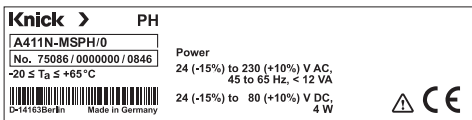
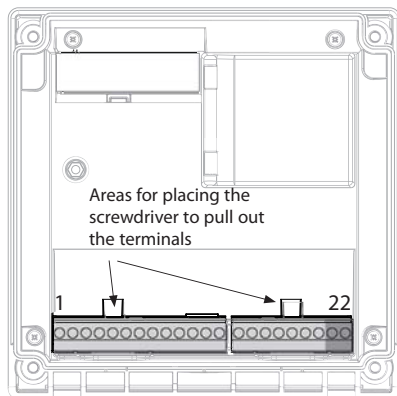

Fig.: Stratos Pro A411N-MSPH rating plate at bottom of front

Power Supply, Signal Lines

Connect the power supply for Stratos Pro A401/A411 MSPH to terminals 21 and 22.

(24 ... 230 V AC, 45 ... 65 Hz / 24 ... 80 V DC)



Assignments

1 (BN)	Power supply
2 (GN)	RS 485 A
3 (YE)	RS 485 B
4 (WH)	GND/shield
5	+ input
6	- input
7	+ out 2
8	- out 2
9	+ out 1/HART
10	- out 1/HART
11	hold
12	hold/control
13	control
14	REL 1
15	REL 1/2
16	REL 2
17	alarm
18	alarm
19	wash
20	wash
21	power
22	power

Fig.: Terminals, device opened, back of front unit

Sensor Connection

Connect the sensor lines with the sensor connection (RS-485, terminals A...K).

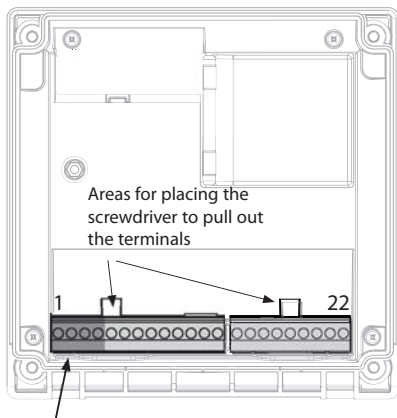

Sensor connection
RS-485

Fig.: Terminals, device opened, back of front unit

Example 1:

Measuring task: pH/ORP, temp, glass impedance, ref. impedance

Sensors (example): SE 533/1-ADIN (Knick)

Cable (example): CA/003-NAADIN11 (Knick)

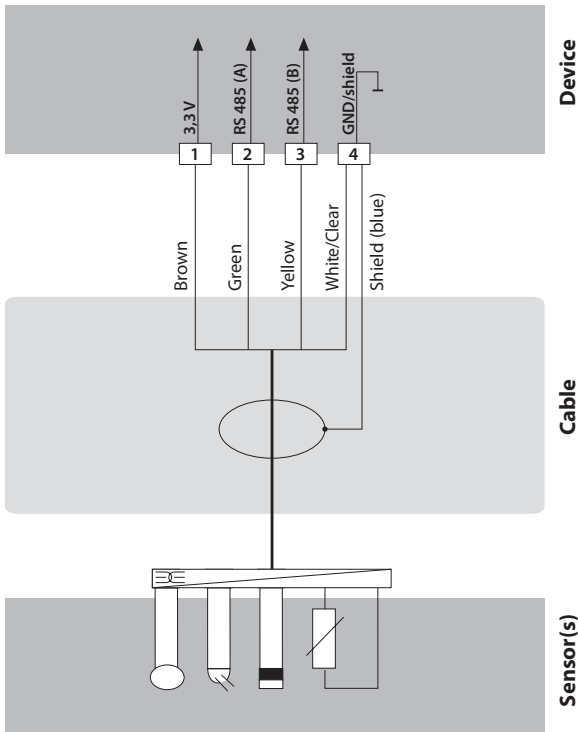

Example 2:

Measuring task: pH/ORP, temp, glass impedance

Sensors (example): SE531/1-NMSN (Knick)

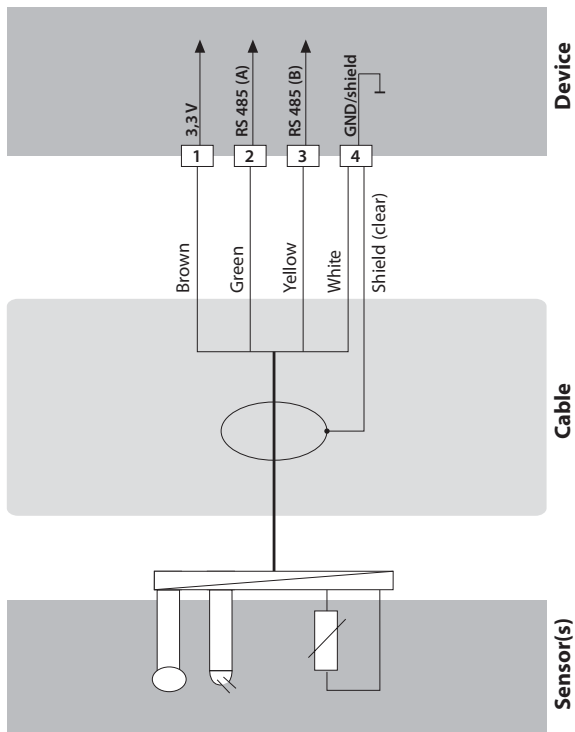

Protective Wiring of Relay Contacts

Protective Wiring of Relay Contacts

Relay contacts are subject to electrical erosion. Especially with inductive and capacitive loads, the service life of the contacts will be reduced. For suppression of sparks and arcing, components such as RC combinations, nonlinear resistors, series resistors, and diodes should be used.

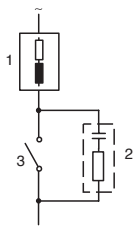
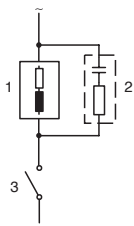

Typical AC applications with inductive load

- 1 Load
- 2 RC combination, e.g. RIFA PMR 209
Typical RC combinations for 230 V AC:
capacitor 0.1 μF / 630 V,
resistor 100 Ω / 1 W
- 3 Contact

Protective Wiring of Relay Contacts

Typical Protective Wiring Measures

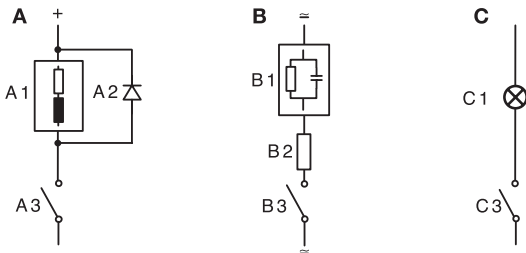

- A:** DC application with inductive load
B: AC/DC applications with capacitive load
C: Connection of incandescent lamps

- A1 Inductive load
A2 Free-wheeling diode, e.g. 1N4007 (Observe polarity)
A3 Contact
B1 Capacitive load
B2 Resistor, e.g. $8\ \Omega$ / 1 W at 24 V / 0.3 A
B3 Contact
C1 Incandescent lamp, max 60 W / 230 V, 30 W / 115 V
C3 Contact



WARNING!

Make sure that the maximum ratings of the relay contacts are not exceeded even during switching!

User Interface, Keypad

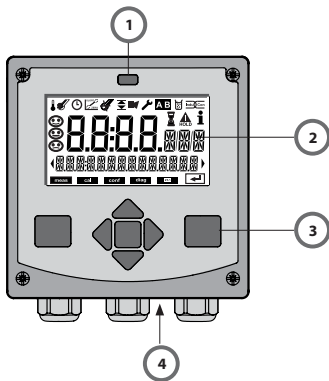

- 1 IrDA transmitter/receiver
- 2 Display
- 3 Keypad
- 4 Rating plate (bottom)

Key	Function
meas	<ul style="list-style-type: none">• Return to last menu level• Directly to measuring mode (press > 2 s)
info	<ul style="list-style-type: none">• Retrieve information• Show error messages
enter	<ul style="list-style-type: none">• Configuration: Confirm entries, next configuration step• Calibration: Continue program flow• Measuring mode: Display output current
Arrow keys up / down	<ul style="list-style-type: none">• Measuring mode: Call menu• Menu: Increase/decrease a numeral• Menu: Selection
Arrow keys left / right	<ul style="list-style-type: none">• Measuring mode: Call menu• Menu: Previous/next menu group• Number entry: Move between digits

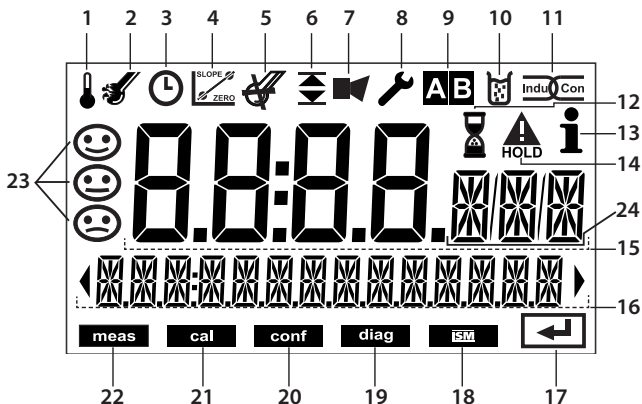

- | | |
|-----------------------------|-----------------------|
| 1 Temperature | 13 Info available |
| 2 Sensocheck | 14 HOLD mode active |
| 3 Interval/response time | 15 Main display |
| 4 Sensor data | 16 Secondary display |
| 5 Digital sensor devaluated | 17 Proceed with enter |
| 6 Limit values | 18 Digital sensor |
| 7 Alarm | 19 Diagnostics |
| 8 Service | 20 Configuration mode |
| 9 Parameter sets A/B | 21 Calibration mode |
| 10 Calibration | 22 Measuring mode |
| 11 Digital sensor | 23 Sensoface |
| 12 Waiting time running | 24 Measurement symbol |

Signal Colors (Display Backlighting)

- | | |
|-----------|---|
| Red | Alarm |
| Orange | HOLD mode (Calibration, Configuration, Service) |
| Turquoise | Diagnostics |
| Green | Info |
| Purple | Sensoface message |

Measuring Mode

After the operating voltage has been connected, the device automatically goes to "Measuring" mode. To call the measuring mode from another operating mode (e.g. Diagnostics, Service):
Hold **meas** key depressed (> 2 s).

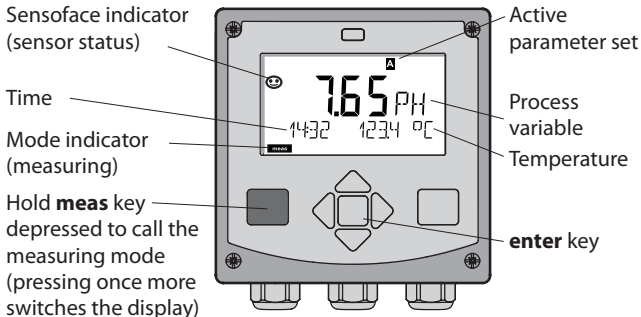

In measuring mode the display indicates:

- Measured value and time (24/12 h AM/PM) as well as temperature in °C or °F (formats selected during configuration)

By pressing the **meas** key in measuring mode you can view the following displays (for approx. 60 sec):

- Measured value and selection of parameter set A/B (if set to "Manual")
- Measured value and tag (point of measurement designation – entered during configuration)
- Time and date
- Controller (if configured), upper display: controller output Y, lower display: setpoint

Pressing the **enter** key shows the output currents. They are displayed as long as **enter** is held depressed, then the measured-value display will return after 3 sec.



The device must be configured for the respective measurement task!

Selecting the Mode / Entering Values

To select the operating mode:

- 1) Hold **meas** key depressed (> 2 s) (measuring mode)
- 2) Press any arrow key: the selection menu appears
- 3) Select operating mode using left / right arrow key
- 4) Press **enter** to confirm the selected mode

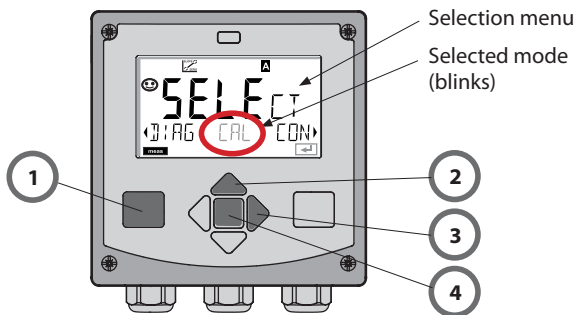

To enter a value:

- 5) Select numeral: left / right arrow key
- 6) Change numeral: up / down arrow key
- 7) Confirm entry with **enter**

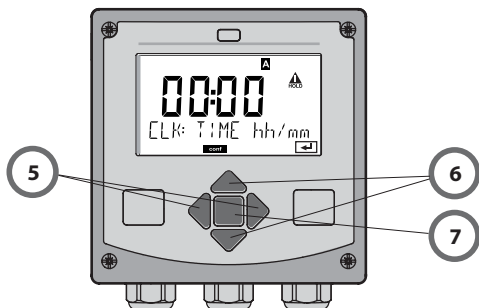

Operating Modes

Diagnostics

Display of calibration data, display of sensor data, performing a device self-test, viewing the logbook entries, display of hardware/software versions of the individual components. The logbook can store 100 events (00...99). They can be displayed directly on the device. The logbook can be extended to 200 entries using a TAN (Option).

HOLD

Manual activation of HOLD mode, e.g. for replacing a digital sensor. The signal outputs adopt a defined state.

Calibration

Every sensor has typical characteristic values, which change in the course of the operating time. Calibration is required to supply a correct measured value. The device checks which value the sensor delivers when measuring in a known solution. When there is a deviation, the device can be "adjusted". In that case, the device displays the "actual" value and internally corrects the measurement error of the sensor. Calibration must be repeated at regular intervals. The time between the calibration cycles depends on the load on the sensor. During calibration the device is in HOLD mode.

During calibration the analyzer remains in the HOLD mode until it is stopped by the operator.

Configuration

The analyzer must be configured for the respective measurement task. In the "Configuration" mode you select the connected sensor, the measuring range to be transmitted, and the conditions for warning and alarm messages. During configuration the device is in HOLD mode.

Configuration mode is automatically exited 20 minutes after the last keystroke. The device returns to measuring mode.

Service

Maintenance functions (current source, relay test, controller test), IrDA operation, passcode assignment, reset to factory settings, enabling of options (TAN).

Menu Structure of Modes and Functions



Pressing any arrow key opens the selection menu.
 Select the menu group using the left/right arrow keys.
 Press **enter** to open a menu. Press **meas** to return.

		
DIAG	<ul style="list-style-type: none"> CALDATA SENSOR SELFTEST LOGBUCH MONITOR VERSION 	<ul style="list-style-type: none"> Display of calibration data Display of sensor data Self test: RAM, ROM, EEPROM, module 100 events with date and time Display of measured values (mV_pH, mV_ORP, RTD, resistances of glass electrode, reference electrode) Display of software version, model designation, serial number
HOLD		Manual activation of HOLD mode, e.g. for sensor replacement. The signal outputs behave as configured (e.g. last measured value, 21 mA)
CAL	<ul style="list-style-type: none"> CAL_PH CAL_ORP P_CAL ISFET-ZERO CAL_RTD 	<ul style="list-style-type: none"> pH adjustment (as configured) ORP adjustment Product calibration Zero adjustment (for ISFET only) Adjustment of temperature probe
CONF	<ul style="list-style-type: none"> PARSET A PARSET B 	<ul style="list-style-type: none"> Configuring parameter set A Configuring parameter set B
SERVICE (Access via code, factory setting: 5555)	<ul style="list-style-type: none"> MONITOR OUT1 OUT2 RELAIS CONTROL IRDA CODES DEFAULT OPTION 	<ul style="list-style-type: none"> Display of measured values for validation (simulators) Current source, output 1 Current source, output 2 Relay test Controller: manual specification of controller output Activating the IrDA interface Specifying access codes for operating modes Reset to factory setting Enabling an option via TAN

HOLD Mode

The HOLD mode is a safety state during configuration and calibration. Output current is frozen (Last) or set to a fixed value (Fix). Alarm and limit contacts are disabled. The HOLD mode is indicated by orange display backlighting.

HOLD mode, display icon:



Output Signal Response

- **Last:** The output current is frozen at its last value. Recommended for short configuration procedures. The process should not change decisively during configuration. Changes are not noticed with this setting!
- **Fix:** The output current is set to a value that is noticeably different from the process value to signal the control system that the device is being worked at.

Output Signal During HOLD:

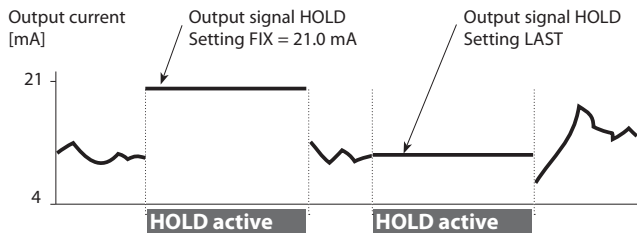

Terminating the HOLD Mode

The HOLD mode is ended by switching to measuring mode (hold **meas** key depressed). The display reads "Good Bye", after that, the HOLD mode is exited.

When the calibration mode is exited, a confirmation prompt ensures that the installation is ready for operation (e.g.: sensor reinstalled, located in process).

External Activation of HOLD

The HOLD mode can be activated from outside by sending a signal to the Hold input (e.g. from the process control system).

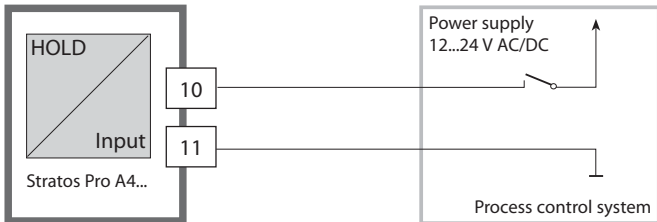

HOLD inactive	0...2 V AC/DC
HOLD active	10...30 V AC/DC

Manual Activation of HOLD

The HOLD can be activated manually from the HOLD menu. This allows checking or replacing a sensor, for example, without provoking unintended reactions of outputs or contacts. Press **meas** key to return to selection menu.

Alarm

When an error has occurred, **Err xx** is displayed immediately. Only after expiry of a user-defined delay time will the alarm be registered and entered in the logbook. During an alarm the display blinks, the display backlighting turns **red**.

Error messages can also be signaled by a 22 mA output current (see Configuration).

The alarm contact is activated by alarm and power failure, see also "Configuration / Alarm Settings".

2 sec after the failure event is corrected, the alarm status will be deleted.

Configuration

Menu Structure of Configuration

The device provides 2 parameter sets "A" and "B". By switching between the parameter sets you can adapt the device to different measurement situations, for example.

Parameter set "B" only permits setting of process-related parameters.

The configuration steps are assigned to different menu groups.

Using ◀ and ▶ you can jump between the individual menu groups.

Each menu group contains menu items for setting the parameters.

Pressing **enter** opens a menu item.

The values are edited using ▲ and ▼. Pressing **enter** confirms/stores the settings.

Return to measurement: Press **meas**.

Select menu group	Menu group	Code	Display	Select menu item
	Sensor selection	SNS:	Conf SENSOR	enter enter enter enter
		Menu item 1		
		:		
		Menu item ...		
▶	Current output 1	OT1:	Conf OUT 1	◀ ▶ ◀ ▶ ◀ ▶ ◀ ▶ ◀ ▶
▶	Current output 2	OT2:	Conf OUT 2	
▶	Compensation	COR:	Conf CORRECT:ON	
▶	Alarm mode	ALA:	Conf ALARM	
▶	Relay outputs	REL:	Conf REL 1/REL 2	
▶	Cleaning	WSH:	Conf WASH	
▶	Setting the clock	CLK:	Conf CLOCK	
▶	Tag number	TAG:	Conf TAG	

Parameter Set A/B: Configurable Menu Groups



(Some parameters are identical in A and B. They are configured in parameter set A only.)

Menu group	Parameter set A	Parameter set B
SENSOR	Sensor selection	---
OUT1	Current output 1	Current output 1
OUT2	Current output 2	Current output 2
CORRECTION	Compensation	Compensation
ALARM	Alarm mode	Alarm mode
REL 1/REL 2	Relay outputs	Relay outputs
WASH	Cleaning	---
PARSET	Parameter set selection	---
CLOCK	Setting the clock	---
TAG	Tag number	---

Parameter Set Selection

Parameter Set A/B

Manual Selection. Signaling via WASH Contact.

Display	Action	Remark
	To switch between parameter sets: Press meas	Manual selection of parameter sets must have been preset in CONFIG mode. Default setting is a fixed parameter set A. Wrong settings change the measurement properties!
	PARSET blinks in the lower line. Select parameter set using ◀ and ▶ keys	
	Select PARSET A / PARSET B	
	Confirm with enter Cancel with meas	

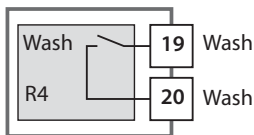

The active parameter set can be displayed using the WASH contact:

If configured correspondingly, the WASH contact signals:
"Parameter set A" (open contact)
"Parameter set B" (closed contact)

Configuration		Choices	Default
Sensor (SENSOR)			
SNS:		MEMOSENS INDUCON	MEMOSENS
	TEMP UNIT	°C / °F	°C
	TEMP MEAS	AUTO MAN EXT (only if enabled via TAN)	AUTO
	MAN	-20...200 °C (-4...392 °F)	025.0 °C (077.0 °F)
	TEMP CAL	AUTO MAN EXT (only if enabled via TAN)	AUTO
	MAN	-20...200 °C (-4...392 °F)	025.0 °C (077.0 °F)
	CAL MODE	AUTO, MAN, DAT	AUTO
	AUTO BUFFER SET	-00-...-09-, -U1- Please note: Pressing info displays nominal buffer values and manufacturers	-00-
	U1 (For specifiable buffer set, see Appendix: "Buffer Tables")	EDIT BUFFER 1 (NO, YES) Enter values for buffer 1	NO
		EDIT BUFFER 2 (NO, YES) Enter values for buffer 2	NO
	CAL TIMER	OFF, FIX, ADAPT	OFF
ON	CAL-CYCLE	0...9999 h	0168 h
DS (InduCon)	CIP COUNT		ON/OFF
	ON	CIP CYCLES	0...9999 CYC
	SIP COUNT		ON/OFF
	ON	SIP CYCLES	0...9999 CYC

Configuration

Configuration		Choices	Default	
Output 1 (OUT1)				
OT1:	RANGE	0–20 mA, 4–20 mA	4-20 mA	
	CHANNEL	PH/ORP/TMP	PH	
	PH	BEGIN 4mA (0 mA)	–2.00...16 PH	00.00 PH
		END 20 mA	–2.00...16 PH	14.00 PH
	ORP	BEGIN 4mA (0 mA)	–1999...1999 mV	
		END 20 mA	–1999...1999 mV	
	TMP °C	BEGIN 4mA (0 mA)	–20...300 °C	Select °C/°F for “Sensor”
		END 20 mA	–20...300 °C	
	TMP °F	BEGIN 4mA (0 mA)	–4...572 °F	
		END 20 mA	–4...572 °F	
	FILTERTIME	0...120 SEC	0000 SEC	
	22mA-FAIL	ON/OFF	OFF	
	HOLD MODE	LAST/FIX	LAST	
	FIX	HOLD-FIX	(0) 4...22 mA	021.0 mA
Output 2 (OUT2)				
OT2:	RANGE	0–20 mA, 4–20 mA	4-20 mA	
	CHANNEL	PH/ORP/TMP	TMP	
	PH	BEGIN 4mA (0 mA)	–2.00...16 PH	00.00 PH
		END 20 mA	–2.00...16 PH	14.00 PH
	ORP	BEGIN 4mA (0 mA)	–1999...1999 mV	
		END 20 mA	–1999...1999 mV	
	TMP °C	BEGIN 4mA (0 mA)	–20...300 °C	Select °C/°F for “Sensor”
		END 20 mA	–20...300 °C	
	TMP °F	BEGIN 4mA (0 mA)	–4...572 °F	
		END 20 mA	–4...572 °F	
	FILTERTIME	0...120 SEC	0000 SEC	
	22mA-FAIL	ON/OFF	OFF	
	HOLD MODE	LAST/FIX	LAST	
	FIX	HOLD-FIX	(0) 4...22 mA	021.0 mA

Configuration		Choices	Default		
Temperature compensation (CORRECTION)					
COR:	TC LIQUID		-19.99...19.99%/K	00.00%/K	
	TEMP EXT*		ON/OFF	OFF	
	ON	I-INPUT		0...20 mA/4...20 mA	4...20 mA
		°C	BEGIN 4 mA	-20...200 °C	000.0 °C
			END 20 mA	-20...200 °C	100.0 °C
		°F	BEGIN 4 mA	-4...392 °F	032.0 °F
			END 20 mA	-4...392 °F	212.0 °F
Alarm (ALARM)					
ALA:	DELAYTIME		0...600 SEC	0010 SEC	
	SENSOCHECK		ON/OFF	OFF	
Relay 1/2 (RL1/RL2)					
REL:	(Selected in text line)		LIMITS, CONTROLLER	LIMITS	
	RL1:	CHANNEL		PH/ORP/TMP	PH
		FUNCTION		Lo LEVEL, Hi LEVEL	Lo LEVEL
		CONTACT		N/O, N/C	N/O
		LEVEL		-2.00...16 PH (-1999...1999 mV) (-20...200 °C)	00.00 PH
		HYSTERESIS		0...10.00 PH	00.50 PH
		DELAYTIME		0...9999 SEC	0010 SEC
	RL2:	CHANNEL		PH/ORP/TMP	PH
		FUNCTION		Lo LEVEL, Hi LEVEL	Hi LEVEL
		CONTACT		N/O, N/C	N/O
		LEVEL		-2.00...16 PH (-1999...1999 mV) (-20...200 °C)	14.00 PH
		HYSTERESIS		0...10.00 PH	00.50 PH
		DELAYTIME		0...9999 SEC	0010 SEC
	*) is only displayed if enabled and SENSOR TEMP EXT has been selected.				

Configuration

Configuration		Choices		Default	
REL:	CTR	CHANNEL		PH/ORP/TMP	PH
		TYPE		PLC / PFC	PLC
		PLC	PULSE LEN	0...0600 SEC	0010 SEC
		PFC	PULSE FREQ	0...0180 P/M	0060 P/M
		SETPOINT		-2.00...16 PH -1500...1500 mV	07.00 PH
		DEAD BAND		0...10.00 PH	01.00 PH
		P-GAIN		10...9999%	0100%
		I-TIME		0...9999 SEC	0000 SEC
		D-TIME		0...9999 SEC	0000 SEC
HOLD MODE		Y LAST/Y OFF	Y LAST		
Cleaning contact (WASH)					
WSH:	(Select text line)		WASH PARSET A/B	WASH	
	WASH	WASH CYCLE	0.0...999.9 h	000.0 h	
		WASH TIME	0...9999 SEC	0060 SEC	
		CONTACT	N/O, N/C	N/O	
Parameter set (PARSET)					
PAR:	Select fixed parameter set (A) or switch between A/B via control input or manually in measuring mode		PARSET FIX / CNTR INPUT / MANUAL	PARSET FIX (fixed parameter set A)	
Real-time clock (CLOCK)					
CLK:	FORMAT		24 h / 12 h		
	24 h	TIME hh/mm	00..23:00...59	00:00	
	12 h	TIME hh/mm	00...11 AM/ PM:00...59	00.00	
	DAY/MONTH		01...31/01...12	31.12.	
	YEAR		2000...2099	2006	
Tag number (TAG)					
TAG:	(Input in text line)			—	

Configuration (Original for Copy)

Two complete parameter sets are stored in the EEPROM.
As delivered, the two sets are identical but can be edited.

Please note:

Fill in your configuration data on the following pages or use them as original for copy.

Parameter	Parameter set A	Parameter set B
SNS: Sensor type		--- *)
SNS: Temperature unit		---
SNS: Temp measurement		---
SNS: Manual meas. temp		---
SNS: Calibration temp		---
SNS: Manual cal temp		---
SNS: Calibration mode		---
SNS: Select buffer set (-U1-, see Appendix)		---
SNS: Calibration timer		---
SNS: Calibration cycle		---
SNS: CIP counter		---
SNS: CIP cycles		---
SNS: SIP counter		---
SNS: SIP cycles		---
OT1: Current range		
OT1: Process variable		
OT1: Current start		
OT1: Current end		

*) These parameters cannot be adjusted in parameter set B,
the values are the same as in parameter set A.

(Original for Copy) Configuration

Parameter	Parameter set A	Parameter set B
OT1: Filter time		
OT1: 22 mA error current		
OT1: HOLD mode		
OT1: HOLD-FIX current		
OT2: Current range		
OT2: Process variable		
OT2: Current start		
OT2: Current end		
OT2: Filter time		
OT2: 22 mA error current		
OT2: HOLD mode		
OT2: HOLD-FIX current		
COR: Temp coefficient		
COR: Ext. temp input		
COR: Current range		
COR: Current start		
COR: Current end		
ALA: Delay		
ALA: Sensocheck on/off		
REL: Usage		
RL1: Process variable		
RL1: Function		
RL1: Contact response		
RL1: Setpoint		
RL1: Hysteresis		
RL1: Delay		
RL2: Process variable		
RL2: Function		
RL2: Contact response		

Configuration (Original for Copy)

Parameter	Parameter set A	Parameter set B
RL2: Setpoint		
RL2: Hysteresis		
RL2: Delay		
CTR: Process variable		
CTR: Controller type		
CTR: Pulse length		
CTR: Pulse frequency		
CTR: Setpoint		
CTR: Neutral zone		
CTR: P gain		
CTR: I time		
CTR: D time		
CTR: HOLD mode		
WSH: Usage		--- *)
WSH: Wash cycle		---
WSH: Wash duration		---
WSH: Contact response		---
PAR: Parameter set selection		---
CLK: Time format		---
CLK: Time hh/mm		---
CLK: Day/month		---
CLK: Year		---
TAG: Tag number		---

*) These parameters cannot be adjusted in parameter set B, the values are the same as in parameter set A.

Configuration

Sensor

Select: sensor type, temperature unit,
temp detection during measurement



enter



enter

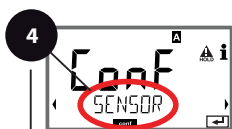

enter

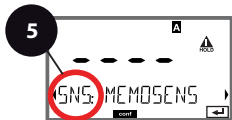

meas



- 1 Press any arrow key.
- 2 Select **CONF** using ◀ ▶ keys, press **enter**.
- 3 Select parameter set using ◀ ▶ keys, press **enter**.
- 4 Select **SENSOR** menu using ◀ ▶ keys, press **enter**.
- 5 All items of this menu group are indicated by the "SNS:" code. Press **enter** to select menu, edit with arrow keys (see next page). Confirm (and proceed) with **enter**.
- 6 End: Press **meas** key until the [meas] mode indicator is displayed.

5

Select sensor type	enter
Temperature unit	enter
Temp detection during measurement	enter
(Man. temperature)	
Temp detection during calibration	
(Man. temperature)	
Calibration mode	
(AUTO: Buffer set)	
Calibration timer	
Calibration cycle	
Cleaning cycle counter	
Cleaning cycles	
Sterilization cycle counter	
Sterilization cycles	

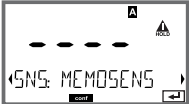
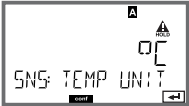
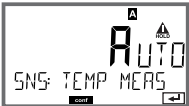
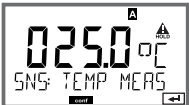
Menu item	Action	Choices
Select sensor type 	Select sensor type using ▲ ▼ keys. Confirm with enter	STANDARD ISFET INDUCON (DS) ISM-DISO (DS) MEMOSENS (DS)
Temperature unit 	Select °C or °F using ▲ ▼ keys. Confirm with enter	°C / °F
Temp detection during measurement 	Select mode using ▲ ▼ : AUTO: Measured by sensor MAN: Direct input of temperature, no measurement (see next step) EXT: Temperature specified via current input (only if TAN E enabled) Confirm with enter	AUTO MAN EXT
(Manual temperature) 	Modify digit using ▲ ▼ , select next digit using ◀ ▶ keys. Confirm with enter	-20...200 °C (-4...+392 °F)

Configuration

Sensor



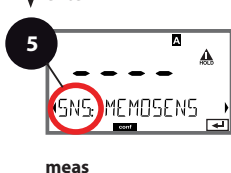
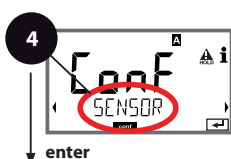

Select: temp detection during calibration, calibration mode

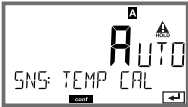

- 1 Press any arrow key.
- 2 Select **CONF** using ◀ ▶ keys, press **enter**.
- 3 Select parameter set using ◀ ▶ keys, press **enter**.
- 4 Select **SENSOR** menu using ◀ ▶ keys, press **enter**.
- 5 All items of this menu group are indicated by the "SNS:" code.
Press **enter** to select menu, edit with arrow keys (see next page). Confirm (and proceed) with **enter**.
- 6 End: Press **meas** key until the [meas] mode indicator is displayed.

5

Select sensor type	enter
Temperature unit	enter
Temp detection during measurement (Man. temperature)	enter
Temp detection during calibration (Man. temperature)	enter
Calibration mode (AUTO: Buffer set)	enter
Calibration timer	
Calibration cycle	
Cleaning cycle counter	
Cleaning cycles	
Sterilization cycle counter	
Sterilization cycles	

Menu item	Action	Choices
Temp detection during calibration 	Select mode using \blacktriangle \blacktriangledown : AUTO: Measured by sensor MAN: Direct input of temperature, no measurement (see next step) EXT: Temperature specified via current input (only if TAN E enabled) Confirm with enter	AUTO MAN EXT
(Manual temperature) 	Modify digit using \blacktriangle \blacktriangledown , select next digit using \blacktriangleleft \blacktriangleright keys. Confirm with enter	-20...200 °C (-4...+392 °F)
Calibration Mode 	Select CALMODE using \blacktriangle \blacktriangledown keys: AUTO: Calibration with Calimatic buffer set recognition MAN: Manual input of buffer solutions. DAT: Input of adjustment data of premeasured sensors Confirm with enter	AUTO MAN DAT
(AUTO: Buffer set) 	Select buffer set using \blacktriangle \blacktriangledown keys (see buffer tables for nominal values). Confirm with enter	-00-...-09-, -U1- Pressing the info key displays the manufacturer and nominal values in the lower line.

Configuration

Sensor

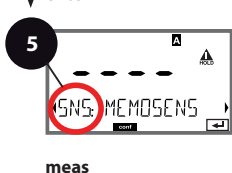
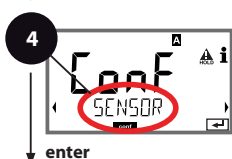

Adjust: calibration timer, calibration cycle



- 1 Press any arrow key.
- 2 Select **CONF** using ◀ ▶ keys, press **enter**.
- 3 Select parameter set using ◀ ▶ keys, press **enter**.
- 4 Select **SENSOR** menu using ◀ ▶ keys, press **enter**.
- 5 All items of this menu group are indicated by the "SNS:" code. Press **enter** to select menu, edit with arrow keys (see next page). Confirm (and proceed) with **enter**.
- 6 End: Press **meas** key until the [meas] mode indicator is displayed.



5

Select sensor type	enter
Temperature unit	
Temp detection during measurement (Man. temperature)	
Temp detection during calibration (Man. temperature)	
Calibration mode (AUTO: Buffer set)	
Calibration timer	
Calibration cycle	
Cleaning cycle counter	
Cleaning cycles	
Sterilization cycle counter	
Sterilization cycles	

Menu item	Action	Choices
Calibration timer 	Adjust CALTIMER using ▲ ▼ keys: OFF: No timer ADAPT: Maximum cal cycle (adjust in the next step) FIX: Fixed cal cycle (adjust in the next step) Confirm with enter	OFF/ADAPT/FIX With ADAPT, the calibra- tion cycle is automatically reduced depending on the sensor load (high temperatures and pH val- ues) and for digital sen- sors also depending on the sensor wear
Calibration cycle 	Only with FIX/ADAPT: Modify digit using ▲ ▼ keys, select next digit using ◀ ▶ keys. Confirm with enter	0...9999 h

Note for the calibration timer:

When Sensocheck has been activated in the Configuration > Alarm menu, the expiration of the calibration interval is indicated by Sensoface:

Display	Status
	Over 80% of the calibration interval has already past.
	The calibration interval has been exceeded.

The calibration timer settings apply to both parameter sets A and B.

The time remaining until the next due calibration can be seen in the diagnostics menu (see Diagnostics chapter).

Configuration

Sensor

Adjust: CIP cleaning cycles, SIP sterilization cycles

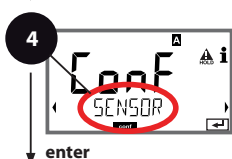

- 1 Press any arrow key.
- 2 Select **CONF** using ◀ ▶ keys, press **enter**.
- 3 Select parameter set using ◀ ▶ keys, press **enter**.
- 4 Select **SENSOR** menu using ◀ ▶ keys, press **enter**.
- 5 All items of this menu group are indicated by the "SNS:" code.
Press **enter** to select menu, edit with arrow keys (see next page). Confirm (and proceed) with **enter**.
- 6 End: Press **meas** key until the [meas] mode indicator is displayed.

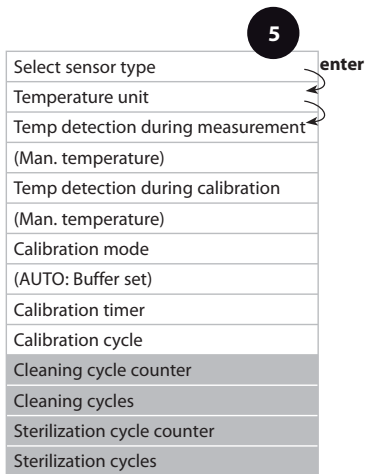

Menu item	Action	Choices
CIP / SIP		
The following adjustments are possible for INDUCON digital sensors:		
Cleaning cycle counter 	Select ON or OFF using ▲ ▼ keys. Activates/deactivates logging in extended logbook and counters (if provided) Confirm with enter	ON/OFF
Cleaning cycles 	Only with CIP COUNT ON: Enter value using ▲ ▼ ◀ ▶ keys. Confirm with enter	0...9999 CYC (0025 CYC) Not with Memosens
Sterilization cycle counter 	Select ON or OFF using ▲ ▼ keys. Activates/deactivates logging in extended logbook and counters (if provided) Confirm with enter	ON/OFF
Sterilization cycles 	Only with SIP COUNT ON: Enter value using ▲ ▼ ◀ ▶ keys. Confirm with enter	0...9999 CYC (0025 CYC) Not with Memosens

The cleaning and sterilization cycles are counted to measure the load on the sensor.

Suitable for biochemical applications (process temp approx. 0...50 °C, CIP temperature > 55 °C, SIP temperature > 115 °C).

Configuration

Current Output 1

Output current range, current start, current end



enter



enter



enter







meas



- 1 Press any arrow key.
- 2 Select **CONF** using ◀ ▶ keys, press **enter**.
- 3 Select parameter set using ◀ ▶ keys, press **enter**.
- 4 Select **OUT1** menu using ◀ ▶ keys, press **enter**.
- 5 All items of this menu group are indicated by the "OT1:" code.
Press **enter** to select menu, edit with arrow keys (see next page). Confirm (and proceed) with **enter**.
- 6 End: Press **meas** key until the [meas] mode indicator is displayed.

5

Current range	enter
Process variable	enter
Current start	enter
Current end	
Time averaging filter	
Output current during error message	
Output current during HOLD	
Output current for HOLD FIX	

Menu item	Action	Choices
Current range 	Select 4-20 mA or 0-20 mA range using \blacktriangle \blacktriangledown keys. Confirm with enter	4-20 mA / 0-20 mA
Process variable 	Select using \blacktriangle \blacktriangledown keys: PH: pH value ORP: Redox potential TMP: Temperature Confirm with enter	PH/ORP/TMP
Current start 	Modify digit using \blacktriangle \blacktriangledown , select next digit using \blacktriangleleft \blacktriangleright keys. Confirm with enter	-2...16 pH (PH) -1999...1999 mV (ORP) -20...300 °C / -4...572 °F (TMP)
Current end 	Enter value using \blacktriangle \blacktriangledown \blacktriangleleft \blacktriangleright keys. Confirm with enter	-2...16 pH (PH) -1999...1999 mV (ORP) -20...300 °C / -4...572 °F (TMP)

Assignment of measured values: Current start and current end

Example 1: Range pH 0...14

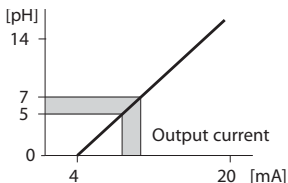

Example 2: Range pH 5...7

Advantage: Higher resolution in range of interest

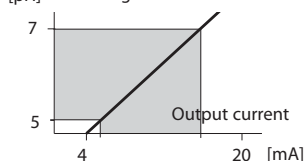

Configuration

Current Output 1

Adjust time interval of output filter

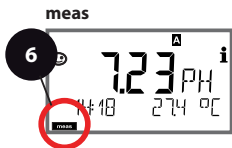
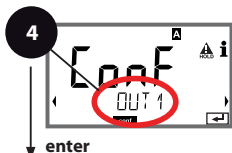

- 1 Press any arrow key.
- 2 Select **CONF** using ◀ ▶ keys, press **enter**.
- 3 Select parameter set using ◀ ▶ keys, press **enter**.
- 4 Select **OUT1** menu using ◀ ▶ keys, press **enter**.
- 5 All items of this menu group are indicated by the "OT1:" code. Press **enter** to select menu, edit with arrow keys (see next page). Confirm (and proceed) with **enter**.
- 6 End: Press **meas** key until the [meas] mode indicator is displayed.

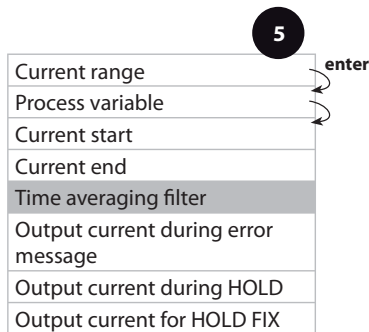

Menu item	Action	Choices
Time averaging filter	Enter value using ▲ ▼ ◀ ▶ keys.	0...120 SEC (0000 SEC)
		Confirm with enter

Time Averaging Filter

To smoothen the current output, a low-pass filter with adjustable filter time constant can be switched on. When there is a jump at the input (100 %), the output level is at 63 % after the time interval has been reached. The time interval can be set from 0 to 120 sec. If the time interval is set to 0 sec, the current output directly follows the input.

Please note:

The filter only acts on the current output, not on the display, the limit values, or the controller!

During HOLD the filter is not applied. This prevents a jump at the output.

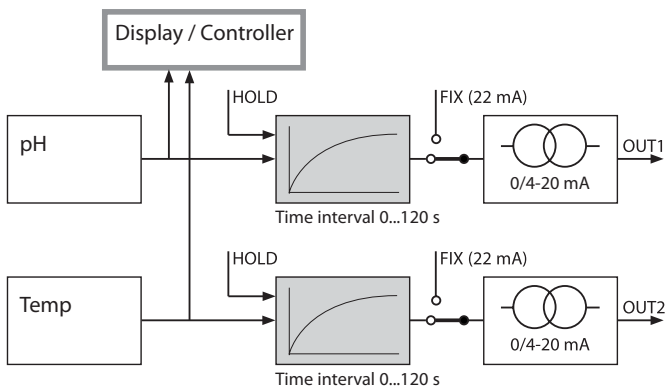

Configuration

Current Output 1

Output current during Error and HOLD



enter



enter



enter





meas

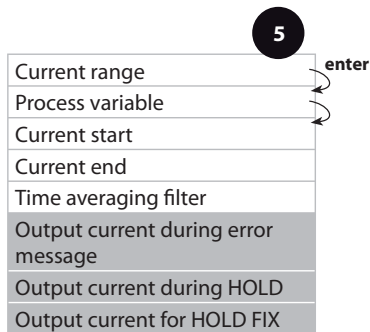

- 1 Press any arrow key.
- 2 Select **CONF** using ◀ ▶ keys, press **enter**.
- 3 Select parameter set using ◀ ▶ keys, press **enter**.
- 4 Select **OUT1** menu using ◀ ▶ keys, press **enter**.
- 5 All items of this menu group are indicated by the "OT1:" code.
Press **enter** to select menu, edit with arrow keys (see next page). Confirm (and proceed) with **enter**.
- 6 End: Press **meas** key until the [meas] mode indicator is displayed.



Menu item	Action	Choices
Output current during error message	Select ON or OFF using \blacktriangle \blacktriangledown keys. Confirm with enter	ON/OFF
		
Output current during HOLD	LAST: During HOLD the last measured value is maintained at the output. FIX: During HOLD a value (to be entered) is maintained at the output. Select using \blacktriangle \blacktriangledown Confirm with enter	LAST/FIX
		
Output current for HOLD FIX	Only with FIX selected: Enter current which is to flow at the output during HOLD Enter value using \blacktriangle \blacktriangledown \blacktriangleleft \blacktriangleright keys. Confirm with enter	00.00...22.00 mA (21.00 mA)
		

Output Signal During HOLD:

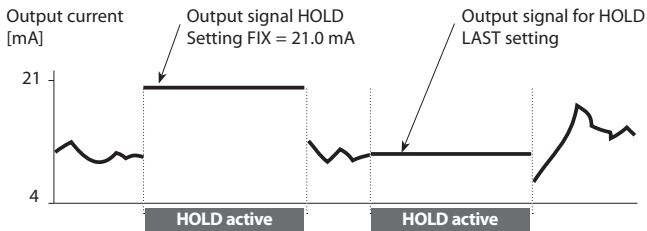

Configuration

Current Output 2



Output current range, current start, current end



- 1 Press any arrow key.
- 2 Select **CONF** using ◀ ▶ keys, press **enter**.
- 3 Select parameter set using ◀ ▶ keys, press **enter**.
- 4 Select **OUT2** menu using ◀ ▶ keys, press **enter**.
- 5 All items of this menu group are indicated by the "OT2:" code. Press **enter** to select menu, edit with arrow keys (see next page). Confirm (and proceed) with **enter**.
- 6 End: Press **meas** key until the [meas] mode indicator is displayed.

5

Current range	enter
Process variable	enter
Current start	
Current end	
Time averaging filter	
Output current during error message	
Output current during HOLD	
Output current for HOLD FIX	

Menu item	Action	Choices
Current range	Select 4-20 mA or 0-20 mA range using ▲ ▼ keys.	4-20 mA / 0-20 mA
	Confirm with enter	
Process variable	Select using ▲ ▼ keys: PH: pH value ORP: Redox potential TMP: Temperature Confirm with enter	PH/ORP/ TMP
		
.		
.		
.		

All the following adjustments are made as for current output 1 (see there)!

Configuration

Temperature Compensation



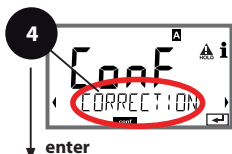

TC process medium, current input for temp measurement

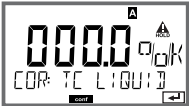
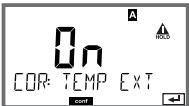

- 1 Press any arrow key.
- 2 Select **CONF** using ◀ ▶ keys, press **enter**.
- 3 Select parameter set using ◀ ▶ keys, press **enter**.
- 4 Select **CORRECTION** menu using ◀ ▶ keys, press **enter**.
- 5 All items of this menu group are indicated by the "COR:" code. Press **enter** to select menu, edit with arrow keys (see next page). Confirm (and proceed) with **enter**.
- 6 End: Press **meas** key until the [meas] mode indicator is displayed.

5

Temperature compensation, process medium	enter
Current input for ext. temperature measurement	enter
Current range	enter
Current start	
Current end	

Menu item	Action	Choices
Temp compensation, process medium 	For pH measurement only: Enter temperature compensation of the process medium. Enter value using ▲ ▼ ◀ ▶ keys. Confirm with enter	-19.99...+19.99 %/K
Current input for ext. temperature measurement 	Only if enabled via TAN and selected during configuration (SENSOR). Select ON or OFF using ▲ ▼ keys. Confirm with enter	ON/OFF
Current range 	Select desired range using ▲ ▼ keys. Confirm with enter	4-20 mA / 0-20 mA
Current start 	Modify digit using ▲ ▼, select next digit using ◀ ▶ keys. Confirm with enter	Input range: -20...200 °C / -4...392 °F
Current end 	Enter value using ▲ ▼ ◀ ▶ keys. Confirm with enter	Input range: -20...200 °C / -4...392 °F

Configuration

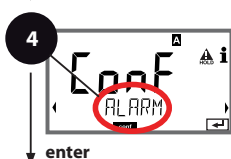

Alarm

Alarm delay, Sensocheck



- 1 Press any arrow key.
- 2 Select **CONF** using ◀ ▶ keys, press **enter**.
- 3 Select parameter set using ◀ ▶ keys, press **enter**.
- 4 Select **ALARM** menu using ◀ ▶ keys, press **enter**.
- 5 All items of this menu group are indicated by the "ALA:" code. Press **enter** to select menu, edit with arrow keys (see next page). Confirm (and proceed) with **enter**.
- 6 End: Press **meas** key until the [meas] mode indicator is displayed.



Menu item	Action	Choices
Alarm delay 	Enter value using ▲ ▼ ◀ ▶ keys. Confirm with enter	0...600 SEC (010 SEC)
Sensocheck 	Select Sensocheck (continuous monitoring of glass and reference electrode) Select ON or OFF using ▲ ▼ keys. Confirm with enter . (At the same time, Sensoface is activated. With OFF, Sensoface is also switched off.)	ON/OFF

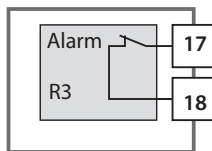

Alarm Contact

The alarm contact is closed during normal operation (N/C). It opens in the case of alarm or power outage. As a result, a failure message is provided even in the case of wire failure or line breakage (fail-safe behavior). For contact ratings, see Specifications.

Error messages can also be signaled by a 22 mA output current (see Error messages and Configuration Output 1/Output 2).

Operating behavior of the alarm contact: see Operating States table.

The alarm delay time delays the color change of the display backlighting to red, the 22 mA signal (if configured), and the alarm contact switching.

Limit Function



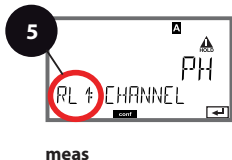
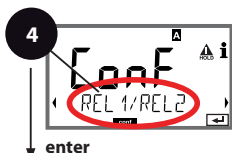

Relay 1

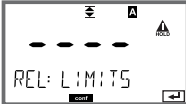

- 1 Press any arrow key.
- 2 Select **CONF** using ◀ ▶ keys, press **enter**.
- 3 Select parameter set using ◀ ▶ keys, press **enter**.
- 4 Select **REL1/REL2** menu using ◀ ▶ keys, press **enter**.
- 5 All items of this menu group are indicated by the "RL1:" code. Press **enter** to select menu, edit with arrow keys (see next page). Confirm (and proceed) with **enter**.
- 6 End: Press **meas** key until the [meas] mode indicator is displayed.

5

Use of relays	enter
Select process variable	↔
Limit 1 switching characteristics (function)	↔
Limit 1 contact type	
Limit 1 setpoint	
Limit 1 hysteresis	
Limit 1 delay	

Menu item	Action	Choices
<p>Use of relays</p> 	<p>Select in the text line using ▲ ▼ keys:</p> <ul style="list-style-type: none"> Limit function (LIMITS) Controller (CONTROLLER) <p>Confirm with enter</p>	<p>LIMITS / CONTROLLER</p> <p>Please note: Selecting CONTROLLER leads to Controller menu group CTR.</p>
<p>Select process variable</p> 	<p>Select desired process variable using ▲ ▼ keys.</p> <p>Confirm with enter</p>	<p>PH/ORP/TMP</p>
<p>Limit 1 function</p> 	<p>Select desired function using arrow keys.</p> <p>LoLevel: active if value falls below / HiLevel: active if value exceeds setpoint</p> <p>Confirm with enter</p>	<p>Lo LEVEL / Hi LEVEL</p>
<p>Limit 1 contact response</p> 	<p>N/O: normally open contact N/C: normally closed contact</p> <p>Select using ▲ ▼ keys.</p> <p>Confirm with enter</p>	<p>N/O / N/C</p>
<p>Limit 1 setpoint</p> 	<p>Enter setpoint using ▲ ▼ ◀ ▶ keys.</p> <p>Confirm with enter</p>	<p>-2.00...16.00 PH (00.00 PH) / -1999...1999 mV / -20...200 °C</p>

Limit Function

Relay 1

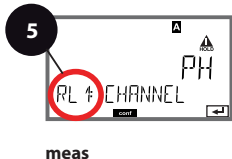

- 1 Press any arrow key.
- 2 Select **CONF** using ◀ ▶ keys, press **enter**.
- 3 Select parameter set using ◀ ▶ keys, press **enter**.
- 4 Select **REL1/REL2** menu using ◀ ▶ keys, press **enter**.
- 5 All items of this menu group are indicated by the "RL1:" code. Press **enter** to select menu, edit with arrow keys (see next page). Confirm (and proceed) with **enter**.
- 6 End: Press **meas** key until the [meas] mode indicator is displayed.

5

Use of relays	enter
Select process variable	↔
Limit 1 switching characteristics (function)	↔
Limit 1 contact type	
Limit 1 setpoint	
Limit 1 hysteresis	
Limit 1 delay	

Menu item	Action	Choices
Limit 1 hysteresis	Select hysteresis using ▲ ▼ ◀ ▶ keys. Confirm with enter	0...10.00 PH (00.50 PH)
Limit 1 delay	The contact is activated with delay (deactivated without delay) Adjust delay using ▲ ▼ ◀ ▶ keys. Confirm with enter	0...9999 SEC (0010 SEC)

Application of Hysteresis:

Limit Lo

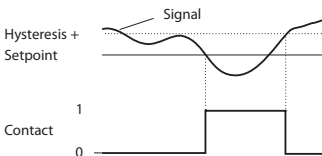

Limit Hi

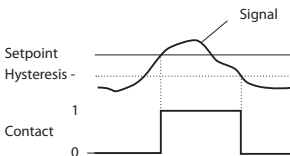

Limit Function

Relay 2



enter



enter



enter



meas



- 1 Press any arrow key.
- 2 Select **CONF** using ◀ ▶ keys, press **enter**.
- 3 Select parameter set using ◀ ▶ keys, press **enter**.
- 4 Select **REL1/REL2** menu using ◀ ▶ keys, press **enter**.
- 5 All items of this menu group are indicated by the "RL2:" code. Press **enter** to select menu, edit with arrow keys (see next page). Confirm (and proceed) with **enter**.
- 6 End: Press **meas** key until the [meas] mode indicator is displayed.

5

Use of relays

Select process variable

Limit 2 switching characteristics (function)

Limit 2 contact type

Limit 2 setpoint

Limit 2 hysteresis

Limit 2 delay

enter

Menu item	Action	Choices
Select process variable (CHANNEL)	Select desired process variable using \blacktriangle \blacktriangledown keys. Confirm with enter	PH/ORP/TMP
Limit 2 function (FUNCTION)	Select desired function using arrow keys. Confirm with enter	Lo LEVEL / Hi LEVEL
Limit 2 contact type (CONTACT)	N/O: normally open contact N/C: normally closed contact Select using \blacktriangle \blacktriangledown keys. Confirm with enter	N/O / N/C
Limit 2 setpoint (LEVEL)	Enter setpoint using \blacktriangle \blacktriangledown \blackleftarrow \blackrightarrow keys. Confirm with enter	-2.00...16.00 PH (14.00 PH) / -1999...1999 mV / -20...200 °C
Limit 2 hysteresis (HYSTERESIS)	Select hysteresis using \blacktriangle \blacktriangledown \blackleftarrow \blackrightarrow keys. Confirm with enter	0...10.00 PH (00.50 PH)
Limit 2 delay (DELAYTIME)	The contact is activated with delay (deactivated without delay) Adjust delay using \blacktriangle \blacktriangledown \blackleftarrow \blackrightarrow keys. Confirm with enter	0...9999 SEC (0010 SEC)

Application of Hysteresis:

Limit Lo

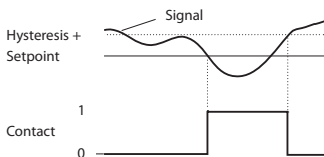

Limit Hi

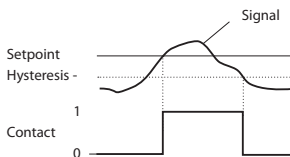

Typical Applications

P Controller

Application for integrating control systems (e.g. closed tank, batch processes).

PI Controller

Application for non-integrating control systems (e.g. drains).

PID Controller

The additional derivative action compensates for measurement peaks.

Controller Characteristic

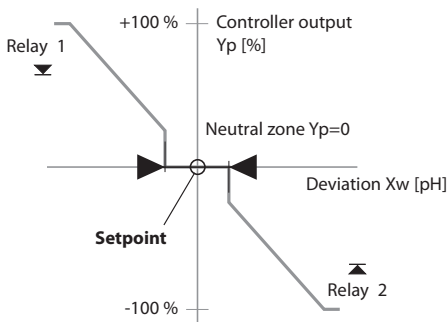

Controller Functions

Controller Equations

$$\text{Controller output } Y = Y_P + \frac{1}{T_R} \int Y_P dt + T_D \frac{dY_P}{dt}$$

P action I action D action

Proportional action Y_P

$$Y_P = \frac{\text{Setpoint} - \text{Meas. value}}{\text{Constant}} * K_C$$

with:

Y_P Proportional action
 T_R Reset time [s]
 T_D Rate time [s]
 K_C Controller gain [%]
Constant 5 (for pH)
 500 mV (for ORP)

Neutral Zone

Tolerated deviation from desired value.

With the setting "1 pH", for example, a deviation of ± 0.5 pH from the desired value is tolerated.

Proportional Action (Gradient K_C [%])

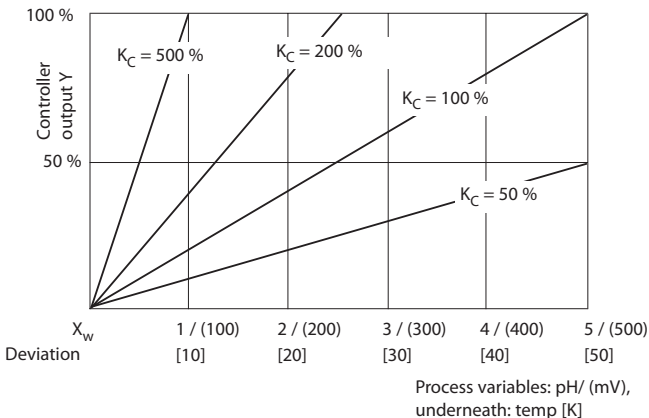

Pulse Length / Pulse Frequency Controller

Pulse Length Controller (PLC)

The pulse length controller is used to operate a valve as an actuator. It switches the contact on for a time that depends on the controller output. The period is constant. A minimum ON time of 0.5 sec is maintained even if the controller output takes corresponding values.

Output signal (relay contact) of pulse length controller:

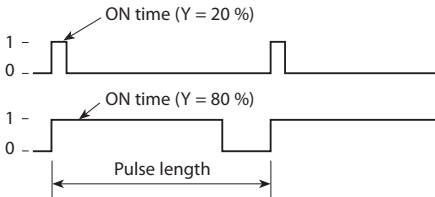

Pulse Frequency Controller (PFC)

The pulse frequency controller is used to operate a frequency-controlled actuator (metering pump). It varies the frequency with which the contacts are switched on. The maximum pulse frequency [pulses/min] can be defined. It depends on the actuator. The contact ON time is constant. It is automatically calculated from the user-defined maximum pulse frequency:

Output signal (relay contact) of pulse frequency controller:

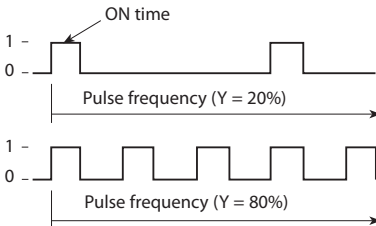

Configuration

Controller

(For description, see Controller Functions)

Process variable. Controller type. Setpoint.



enter



enter



enter







meas



- 1 Press any arrow key.
- 2 Select **CONF** using ◀ ▶ keys, press **enter**.
- 3 Select parameter set using ◀ ▶ keys, press **enter**.
- 4 Select **REL1/REL2** menu using ◀ ▶ keys, press **enter**.
- 5 All items of this menu group are indicated by the "CTR:" code. Press **enter** to select menu, edit with arrow keys (see next page). Confirm (and proceed) with **enter**.
- 6 End: Press **meas** key until the [meas] mode indicator is displayed.

5

Use of relays	enter
Select process variable	↻
Controller type	↻
Pulse length	
Pulse frequency	
Setpoint	
Neutral zone	
Controller: P action	
Controller: I action	
Controller: D action	
Behavior during HOLD	

Menu item	Action	Choices
Select process variable 	Select desired process variable using ▲ ▼ keys. Confirm with enter	PH/ORP/TMP
Controller type 	Pulse length controller (PLC) or pulse frequency controller (PFC) Select using ▲ ▼ keys. Confirm with enter	PLC / PFC
Pulse length 	Only with PLC: Pulse length Adjust using ▲ ▼ ◀ ▶ keys. Confirm with enter	0...0600 SEC (0010 SEC)
Pulse frequency 	Only with PFC: Pulse frequency Adjust using ▲ ▼ ◀ ▶ keys. Confirm with enter	0...0180 P/M (0060 P/M) (pulses per minute)
Setpoint 	Adjust setpoint using ▲ ▼ ◀ ▶ keys. Confirm with enter	-2.00...16.00 PH (07.00 PH) / -1500...1500 mV

Controller

(For description, see **Controller Functions**)

Neutral zone. P, I, D actions. Behavior during HOLD



enter



enter



enter







meas



- 1 Press any arrow key.
- 2 Select **CONF** using ◀ ▶ keys, press **enter**.
- 3 Select parameter set using ◀ ▶ keys, press **enter**.
- 4 Select **REL1/REL2** menu using ◀ ▶ keys, press **enter**.
- 5 All items of this menu group are indicated by the "CTR:" code.
Press **enter** to select menu, edit with arrow keys (see next page). Confirm (and proceed) with **enter**.
- 6 End: Press **meas** key until the [meas] mode indicator is displayed.

5

Use of relays	enter
Select process variable	↔
Controller type	↔
Pulse length	
Pulse frequency	
Setpoint	
Neutral zone	
Controller: P action	
Controller: I action	
Controller: D action	
Behavior during HOLD	

Menu item	Action	Choices
Neutral zone 	Adjust neutral zone using ▲ ▼ ◀ ▶ keys. Confirm with enter	0...10.00 PH (01.00 PH) / 0...2000 mV
Controller: P action 	Adjust P action using ▲ ▼ ◀ ▶ keys. Confirm with enter	10...9999% (0100%)
Controller: I action 	Adjust I action using ▲ ▼ ◀ ▶ keys. Confirm with enter	0...9999 SEC (0000 SEC)
Controller: D action 	Adjust D action using ▲ ▼ ◀ ▶ keys. Confirm with enter	0...9999 SEC (0000 SEC)
Behavior during HOLD 	Select response using ▲ ▼ keys. Confirm with enter	Y LAST / Y OFF

Configuration

WASH Contact

Control of rinsing probes or signaling the parameter set



enter



enter



enter



meas



- 1 Press any arrow key.
- 2 Select **CONF** using ◀ ▶ keys, press **enter**.
- 3 Select parameter set A using ◀ ▶ keys, press **enter**.
- 4 Select **WASH** menu using ◀ ▶ keys, press **enter**.
- 5 All items of this menu group are indicated by the "WSH:" code. Press **enter** to select menu, edit with arrow keys (see next page). Confirm (and proceed) with **enter**.
- 6 End: Press **meas** key until the [meas] mode indicator is displayed.

5





Function

Cleaning interval

Cleaning duration

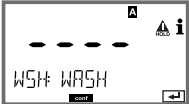
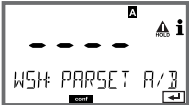
Contact type

enter

Menu item	Action	Choices
Function  	Select WASH contact function using ▲ ▼ keys. Confirm with enter	WASH / PARSET A/B WASH: Control of rinsing probes With PARSET A/B selected, the contact signals: "Parameter set A" (open contact) "Parameter set B" (closed contact)
Cleaning interval 	Only with WASH: Adjust value using ▲ ▼ ◀ ▶ keys. Confirm with enter	0.0...999.9 h (000.0 h)
Cleaning duration 	Only with WASH: Adjust value using ▲ ▼ ◀ ▶ keys. Confirm with enter	0...9999 SEC (0060 SEC)
Contact type 	Only with WASH: N/O: normally open contact N/C: normally closed contact Select using ▲ ▼ keys. Confirm with enter	N/O / N/C

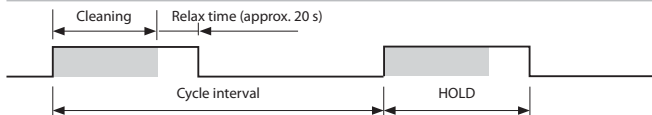

Configuration

Time and Date Tag Number

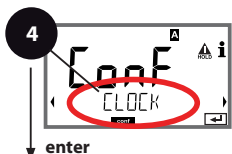

- 1 Press any arrow key.
- 2 Select **CONF** using ◀ ▶ keys, press **enter**.
- 3 Select parameter set A using ◀ ▶ keys, press **enter**.
- 4 Press **enter**
- 5 Select **CLOCK** or **TAG** using ◀ ▶ keys, press **enter**.
- 6 All items of this menu group are indicated by the "CLK:" or "TAG" code. Press **enter** to select menu, edit with arrow keys (see next page). Confirm (and proceed) with **enter**.
- 7 End: Press **meas** key until the [meas] mode indicator is displayed.

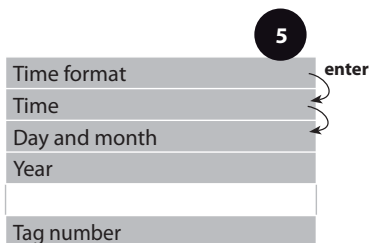

Time and Date

Control of the calibration and cleaning cycles is based on the time and date of the integrated real-time clock.

In measuring mode the time is shown in the lower display.

When using InduCon sensors, the calibration data is written in the sensor head.

In addition, the logbook entries (cf Diagnostics) are provided with a time stamp.

Please note:

- After prolonged power outage (> 5 days) the time display is replaced by dashes and cannot be used for processing.
Enter the correct time.
- There is no automatic switchover from winter to summer time!
Be sure to manually adjust the time!

Tag Number ("TAG")

You can enter a designation for the point of measurement (tag number) in the lower display line. Up to 32 digits are possible.

Pressing **meas** (repeatedly) in the measuring mode indicates the tag number.

Being part of the device configuration, the "TAG" can be read out via IrDA.

A standardized tag number helps, for example, to correctly re-install a device after repair.

5

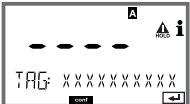
Menu item	Action	Choices
Tag number 	Select character using ▲ ▼ keys, select next digit using ◀ ▶ keys. Confirm with enter	A...Z, 0...9, - + < > ? / @ The first 10 characters are seen in the display with- out scrolling.

Digital Sensors

Operation

Stratos Pro can be operated with three different types of digital sensors (Memosens, InduCon).

The following display examples refer to a transmitter and a digital pH sensor (slight variations for other combinations).

The sensor type is selected during **configuration**.



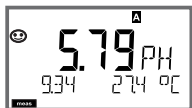

The device only switches to measuring mode when the connected sensor corresponds to the type configured (Sensoface is happy):

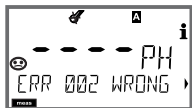

Otherwise, an error message is released. The **info** icon is displayed. You can display the error text in the bottom line using the ◀ ▶ keys. Sensoface is sad (see table of error messages and Sensoface in the Appendix):

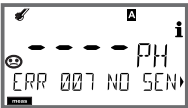

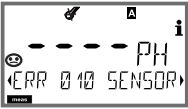

Connecting a Digital Sensor

Step	Action/Display	Remark
Connect sensor		Before a digital sensor is connected, the error message "No sensor" is displayed.
Wait until the sensor data are displayed.		The hourglass in the display blinks.
Check sensor data	 <p>View sensor information using ◀ ▶ keys, confirm with enter.</p>	<p>The display color changes to green.</p> <p>Sensoface is happy.</p>
Go to measuring mode	Press meas , info , or enter	After 60 sec the device automatically returns to measuring mode (timeout).
Possible error messages		
Sensor devaluated Replace sensor		When this error message appears, the sensor cannot be used any more. Sensoface is sad.
Sensor defective Replace sensor		When this error message appears, the sensor cannot be used. Sensoface is sad.

Sensor Replacement

A digital sensor should only be replaced during HOLD mode to prevent unintended reactions of the outputs or contacts. When you first want to calibrate the new sensor, it can also be replaced in calibration mode.

Step	Action/Display	Remark
Select HOLD mode	Press any key to call the selection menu, select HOLD using the ◀ ▶ keys, press enter to confirm.	Now the device is in HOLD mode. The HOLD mode can also be activated externally via the HOLD input. During HOLD the output current is frozen at its last value or set to a fixed value.
Disconnect and remove old sensor		
Install and connect new sensor.		Temporary messages which are activated during the replacement are indicated but not output to the alarm contact and not entered in the log-book.
Wait until the sensor data are displayed.		

Step	Action/Display	Remark
Check sensor data	 <p>View sensor information using ◀ ▶ keys, confirm with enter.</p>	You can view the sensor manufacturer and type, serial number, and last calibration date.
Check measured values		
Exit HOLD	<p>Hit meas key: Return to selection menu.</p> <p>Hold meas key depressed: Device switches to measuring mode</p>	The sensor replacement is entered in the extended logbook.

Calibration

Please note:

- All calibration procedures must be performed by trained personnel. Incorrectly set parameters may go unnoticed, but change the measuring properties.
- The response time of the sensor and temperature probe is considerably reduced when the sensor is first moved about in the buffer solution and then held still.
- The device can only operate properly when the buffer solutions used correspond to the configured set. Other buffer solutions, even those with the same nominal values, may demonstrate a different temperature response. This leads to measurement errors.

When using ISFET sensors or sensors with a zero point other than pH 7, the nominal zero point must be adjusted each time a new sensor is connected. This is important if you want to obtain reliable Sensoface messages. The Sensoface messages issued during all further calibrations are based on this basic calibration.

Selecting a Calibration Mode

Calibration is used to adapt the device to the individual sensor characteristics, namely asymmetry potential and slope.

Access to calibration can be protected with a passcode (SERVICE menu).

First, you open the calibration menu and select the calibration mode:

CAL_PH	Depending on configuration setting: AUTO Automatic buffer recognition (Calimatic) MAN Manual buffer input DAT Input of premeasured electrode data
CAL_ORP	ORP calibration
P_CAL	Product calibration (calibration with sampling)
ISFET-ZERO	Zero adjustment. Required for ISFET sensors, subsequently you can conduct either a one or a two-point calibration.
CAL_RTD	Temperature probe adjustment

To preset CAL_PH (CONF menu / configuration):

- 1) Hold **meas** key depressed (> 2 s) (measuring mode)
- 2) Press any arrow key: the selection menu appears
- 3) Select CONF mode using left / right arrow key
- 4) Select "SENSOR" – "CALMODE": AUTO, MAN, or DAT.
Press **enter** to confirm

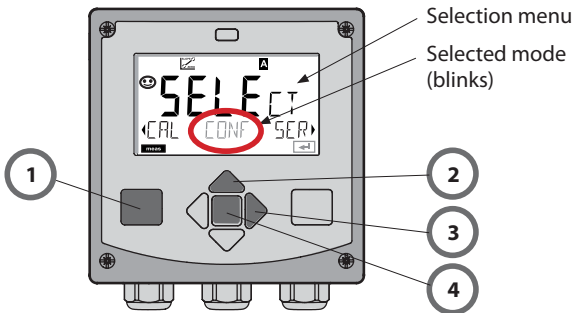





Zero Adjustment (ISFET)

This adjustment allows the use of ISFET sensors with differing nominal zero (pH only). The function is available when Sensor selection = MEMOSENS has been set during configuration. Zero adjustment is disabled for any other sensors.



The adjustment is made using a zero buffer (pH 7.00).

Permitted range for buffer value: pH 6.5 ... 7.5.

Temperature-corrected input. Maximum zero offset: ± 200 mV.

Display	Action	Remark
 The screen displays 'CAL' in large digits, with 'ISFET-ZERO' below it. There are left and right arrow keys at the bottom.	Select Calibration. Press enter to proceed.	
 The screen displays 'CAL' in large digits, with 'ISFET-ZERO' below it. An hourglass icon is visible in the top right corner. There are left and right arrow keys at the bottom.	Ready for calibration. Hourglass blinks.	Display (3 sec) Now the device is in HOLD mode.
 The screen displays '7.00' in large digits, with 'BUF' to the right. Below it, '127mV' and '27.3°C' are shown. There are left and right arrow keys at the bottom.	Immerse sensor in a pH 7.00 buffer. Enter the temperature-corrected pH value in the range 6.50 to 7.50 using the arrow keys (see buffer table). Confirm with enter .	If the zero offset of the sensor is too large ($> \pm 200$ mV), a CAL ERR error message is generated. In that case the electrode cannot be calibrated.
 The screen displays '7.00' in large digits, with 'BUF' to the right. Below it, '128mV' and '27.3°C' are shown. An hourglass icon is visible in the top right corner. There are left and right arrow keys at the bottom.	Stability check. The measured value [mV] is displayed. The "hourglass" icon is blinking.	Please note: Stability check can be stopped (by pressing enter). However, this reduces calibration accuracy.

Zero Adjustment (ISFET)





Display	Action	Remark
 The display shows a large '129' with 'mV' to its right. Below it, 'ISFET-ZERO' is displayed. There are small icons in the top corners and a 'CAL' indicator at the bottom left.	At the end of the adjustment procedure the zero offset [mV] of the sensor is displayed (based on 25 °C). Sensoface is active. Press enter to proceed.	This is not the final calibration value of the sensor! Asymmetry potential and slope must be determined with a complete 2-point calibration.
 The display shows '7.23 PH' in large digits. Below it, 'MEAS REPE' is shown. There are small icons in the top corners and a 'CAL' indicator at the bottom left.	Use the arrow keys to select: <ul style="list-style-type: none">• Repeat (repeat calibration) or• Measuring. Confirm with enter .	
 The display shows '7.23 PH' in large digits. Below it, 'GOOD BYE' is shown. There are small icons in the top corners and a 'CAL' indicator at the bottom left.	Place sensor in process. End zero calibration with enter .	After end of calibration, the outputs remain in HOLD mode for a short time.

Note for Zero Adjustment







After having adjusted the zero offset, be sure to calibrate the sensor following one of the procedures as described on the next pages.

Automatic Calibration (Calimatic)

The AUTO calibration mode and the type of temperature detection are selected during **configuration**. Make sure that the buffer solutions used correspond to the configured buffer set. Other buffer solutions, even those with the same nominal values, may demonstrate a different temperature response. This leads to measurement errors.

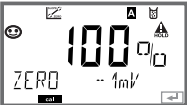



Display	Action	Remark
	Select Calibration. Press enter to proceed.	
	Ready for calibration. Hourglass blinks. Select calibration method: CAL_PH Press enter to proceed.	Display (3 sec) Now the device is in HOLD mode.
	Remove the sensor and temperature probe, clean them, and immerse them in the first buffer solution (in any order). Start with enter	When manual input of temperature has been configured, the temp value in the display blinks and can be edited using the arrow keys.
	Buffer recognition. While the "hourglass" icon is blinking, the sensor and temperature probe remain in the first buffer solution.	The response time of the sensor and temperature probe is considerably reduced when the sensor is first moved about in the buffer solution and then held still.
	Buffer recognition terminated, the nominal buffer value is displayed.	

Automatic Calibration (Calimatic)



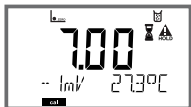

Display	Action	Remark
	<p>At the end of the stability check, the value will be saved and the asymmetry potential will be displayed.</p> <p>Calibration with the first buffer is terminated.</p> <p>Remove the sensor and temp probe from the first buffer solution and rinse them thoroughly.</p> <p>Use the arrow keys to select:</p> <ul style="list-style-type: none"> • END (1-point cal) • CAL2 (2-point cal) • REPEAT <p>Press enter to proceed.</p>	<p>Please note:</p> <p>Stability check can be stopped after 10 sec (by pressing enter). However, this reduces calibration accuracy. Display for 1-point cal:</p>
	<p>Press enter to proceed.</p>	 <p>Sensoface is active. End with enter</p>
	<p>2-point calibration: Immerse sensor and temperature probe in the second buffer solution. Start with enter</p>	<p>The calibration process runs as for the first buffer.</p>
	<p>Retract sensor and temp probe out of second buffer, rinse off, re-install.</p> <p>Press enter to proceed.</p>	<p>The slope and asymmetry potential of the sensor (based on 25 °C) are displayed.</p>
	<p>Use the arrow keys to select:</p> <ul style="list-style-type: none"> • MEAS (end) • REPEAT <p>Press enter to proceed.</p> <p>End: HOLD is deactivated with delay.</p>	<p>When 2-point cal is ended:</p> 

Manual Calibration with Buffer Entry

The MAN calibration mode and the type of temperature detection are selected during **configuration**. For calibration with manual buffer specification, you must enter the pH value of the buffer solution used in the device for the proper temperature. Any desired buffer solution can be used for calibration.

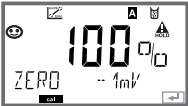
Display	Action	Remark
 The display shows 'CAL' in large digits, 'CAL_PH' below it, and a small hourglass icon in the top right corner. There are also small icons of a beaker and a triangle with a dot.	Select Calibration. Press enter to proceed.	
 The display shows 'CAL' in large digits, 'BUFFER MANUAL' below it, and a small hourglass icon in the top right corner. There are also small icons of a smiley face, a beaker, and a triangle with a dot.	Ready for calibration. Hourglass blinks.	Display (3 sec) Now the device is in HOLD mode.
 The display shows 'CAL M 1' in large digits, '14.31' and '27.40C' below it, and a small hourglass icon in the top right corner. There are also small icons of a beaker and a triangle with a dot.	Remove the sensor and temperature probe, clean them, and immerse them in the first buffer solution. Press enter to start.	When manual input of temperature has been configured, the temp value in the display blinks and can be edited using the arrow keys.
 The display shows '07.00' in large digits, 'BUF' to the right, '14.31' and '27.40C' below it, and a small hourglass icon in the top right corner. There are also small icons of a beaker and a triangle with a dot.	Enter the pH value of your buffer solution for the proper temperature. While the "hourglass" icon is blinking, the sensor and temperature probe remain in the buffer solution.	The response time of the sensor and temperature probe is considerably reduced when the sensor is first moved about in the buffer solution and then held still.
 The display shows '7.00' in large digits, 'mV' below it, and '27.30C' to the right. There is a small hourglass icon in the top right corner. There are also small icons of a beaker and a triangle with a dot.		







Manual Calibration with Buffer Entry

Display	Action	Remark
	<p>At the end of the stability check, the value will be saved and the asymmetry potential will be displayed.</p> <p>Calibration with the first buffer is terminated.</p> <p>Remove the sensor and temp probe from the first buffer solution and rinse them thoroughly.</p> <p>Use the arrow keys to select:</p> <ul style="list-style-type: none"> • END (1-point cal) • CAL2 (2-point cal) • REPEAT <p>Press enter to proceed.</p>	<p>Please note: Stability check can be stopped after 10 sec (by pressing enter). However, this reduces calibration accuracy. Display for 1-point cal:</p>  <p>Sensoface is active. End with enter</p>
	<p>2-point calibration: Immerse sensor and temperature probe in the second buffer solution.</p> <p>Enter pH value.</p> <p>Press enter to start.</p>	<p>The calibration process runs as for the first buffer.</p>
	<p>Rinse sensor and temperature probe and reinstall them.</p> <p>Press enter to proceed.</p>	<p>Display of slope and new asymmetry potential (based on 25 °C).</p>
	<p>Use the arrow keys to select:</p> <ul style="list-style-type: none"> • MEAS (end) • REPEAT <p>Press enter to proceed.</p> <p>End: HOLD is deactivated with delay.</p>	<p>When 2-point cal is ended:</p> 

Data Entry of Premeasured Sensors

The DAT calibration mode must have been preset during configuration.

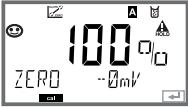
You can directly enter the values for slope and asymmetry potential of a sensor. The values must be known, e.g. determined beforehand in the laboratory.

Display	Action	Remark
	Select Calibration. Press enter to proceed.	
	“Data Input” Ready for calibration. Hourglass blinks.	Display (3 sec) Now the device is in HOLD mode.
	Enter asymmetry potential [mV]. Press enter to proceed.	
	Enter slope [%].	
	The device displays the new slope and asymmetry potential (at 25 °C). Sensoface is active.	
	Use the arrow keys to select: • MEAS (end) • REPEAT Press enter to proceed.	End: HOLD is deactivated with delay.

Converting slope [%] to slope [mV/pH] at 25 °C

%	mV/pH
78	46,2
80	47,4
82	48,5
84	49,7
86	50,9
88	52,1
90	53,3
92	54,5
94	55,6
96	56,8
98	58,0
100	59,2
102	60,4

Converting asymmetry potential to sensor zero point

$$\text{ZERO} = 7 - \frac{V_{AS} [\text{mV}]}{S [\text{mV} / \text{pH}]}$$

ZERO = Sensor zero

V_{AS} = Asymmetry potential

S = Slope

Product Calibration (pH)

Calibration by sampling (one-point calibration).

During product calibration the sensor remains in the process.



The measurement process is only interrupted briefly.

Procedure:



- 1) The sample is measured in the lab or directly on the site using a portable meter. To ensure an exact calibration, the sample temperature should correspond to the measured process temperature. During sampling the device saves the currently measured value and then returns to measuring mode. The "calibration" mode indicator blinks.
- 2) In the second step you enter the measured sample value in the device. From the difference between the stored measured value and entered sample value, the device calculates the new asymmetry potential.

If the sample is invalid, you can take over the value stored during sampling. In that case the old calibration values are stored.

Afterwards, you can start a new product calibration.

Display	Action	Remark
	Select product calibration: P_CAL. Press enter to proceed.	
	Ready for calibration. Hourglass blinks.	Display (3 sec) Now the device is in HOLD mode.
	Take sample and save value. Press enter to proceed.	Now the sample can be measured.

Product Calibration (pH)

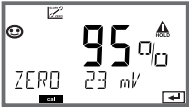
Display	Action	Remark
	The device returns to measuring mode.	From the blinking CAL mode indicator you see that product calibration has not been terminated.
	Product calibration step 2	Display (3 sec) Now the device is in HOLD mode.
	The stored value is displayed (blinking) and can be overwritten with the measured sample value. Press enter to proceed.	
	Display of new asymmetry potential (based on 25°C). Sensoface is active. To end calibration: Select MEAS, then enter	To repeat calibration: Select REPEAT, then enter
End of calibration	After end of calibration, the outputs remain in HOLD mode for a short time.	

ORP (Redox) Calibration

The potential of a redox sensor is calibrated using a redox (ORP) buffer solution. In the course of that, the difference between the measured potential and the potential of the calibration solution is determined according to the following equation. During measurement this difference is added to the measured potential.

$$mV_{\text{ORP}} = mV_{\text{meas}} + \Delta mV$$

mV_{ORP} = displayed ORP

mV_{meas} = direct sensor potential





ΔmV = delta value, determined during calibration

The sensor potential can also be related to another reference system – e.g. the standard hydrogen electrode. In that case the temperature-corrected potential (see table) of the reference electrode used must be entered during calibration. During measurement, this value is then added to the ORP measured.





Please make sure that measurement and calibration temperature are the same since the temperature behavior of the reference electrode is not automatically taken into account.





Temperature Dependence of Commonly Used Reference Systems Measured Against SHE

Temperature [°C]	Ag/AgCl/KCl 1 mol/l [ΔmV]	Ag/AgCl/KCl 3 mol/l [ΔmV]	Thalamid [ΔmV]	Mercury sulfate [ΔmV]
0	249	224	-559	672
10	244	217	-564	664
20	240	211	-569	655
25	236	207	-571	651
30	233	203	-574	647
40	227	196	-580	639
50	221	188	-585	631
60	214	180	-592	623
70	207	172	-598	613
80	200	163	-605	603

Display	Action	Remark
	Select ORP calibration, proceed with enter	
	Remove the sensor and temperature probe, clean them, and immerse them in the redox buffer.	Display (3 sec) Now the device is in HOLD mode.
	Enter setpoint value for redox buffer. Press enter to proceed.	
	The ORP delta value is displayed (based on 25°C). Sensoface is active. Press enter to proceed.	
	To repeat calibration: Select REPEAT. To end calibration: Select MEAS, then press enter	After end of calibration, the outputs remain in HOLD mode for a short time.

Temp Probe Adjustment

Display	Action	Remark
 The display shows 'CAL' in large characters at the top, with 'CAL RTD' below it. There are navigation arrows on the left and right sides.	Select temp adjustment. Press enter to proceed.	Wrong settings change the measurement properties!
 The display shows 'CAL' in large characters at the top, with 'TEMP ADJUST' below it. There is a warning triangle icon in the top right corner.	Measure the temperature of the process medium using an external thermometer.	Display (3 sec) Now the device is in HOLD mode.
 The display shows '25.0' in large characters, with 'OC' to its right. Below it, 'ADJUST' and '235' are visible. There is a warning triangle icon in the top right corner.	Enter the measured temperature value. Maximum difference: 10 K. Press enter to proceed.	Display of actual temperature (uncompensated) in the lower display.
 The display shows '25.0' in large characters, with 'OC' to its right. Below it, 'MEAS' is visible. There is a smiley face icon in the top left corner and a warning triangle icon in the top right corner.	The corrected temperature value is displayed. Sensoface is active. To end calibration: Select MEAS, then enter To repeat calibration: Select REPEAT, then enter	
 The display shows '7.23' in large characters, with 'PH' to its right. Below it, 'GOOD BYE' is visible. There is a smiley face icon in the top left corner and a warning triangle icon in the top right corner.	After calibration is ended, the device will switch to measuring mode.	After end of calibration, the outputs remain in HOLD mode for a short time.

Display	Remark
	<p>From the configuration or calibration menus, you can switch the device to measuring mode by pressing the meas key.</p>
<p>or AM/PM and °F:</p>	<p>In the measuring mode the main display shows the configured process variable (pH, ORP [mV], or temperature), the secondary display shows the time and the second configured process variable (pH, ORP [mV], or temperature). The [meas] mode indicator lights and the active parameter set (A/B) is indicated.</p>
	<p>Please note:</p> <ul style="list-style-type: none"> • After prolonged power outage (> 5 days) the time display is replaced by dashes and cannot be used for processing. Enter the correct time.
	<p>Pressing the enter key briefly shows the output currents. By pressing the meas key you can step through the following displays. When no key has been pressed for 60 sec, the device returns to the standard display.</p>
	<p>1) Selecting the parameter set (if set to "manual" in the configuration). Select the desired parameter set using the ◀ ▶ arrow keys (PARSET A or PARSET B blinks in the lower display line). Confirm with enter.</p>
	<p>Further displays (each with meas).</p> <p>2) Display of tag number ("TAG")</p> <p>3) Display of time and date</p>

Measurement

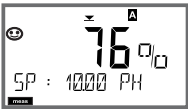
Display	Remark
<p>With activated controller you can also step through the following displays by pressing the meas key. When no key has been pressed for 60 sec, the device returns to the standard display.</p>	
	<p>Main display: Controller output Y Secondary display: Setpoint Depending on configuration setting: pH, mV, or temperature.</p>

In the Diagnostics mode you can access the following menus without interrupting the measurement:

CALDATA	Viewing the calibration data
SENSOR	Viewing the sensor data
SELFTEST	Starting a device self-test
LOGBOOK	Viewing the logbook entries
MONITOR	Displaying currently measured values
VERSION	Displaying device type, software version, serial number







Access to diagnostics can be protected with a passcode (SERVICE menu).





Please note:

HOLD is not active during Diagnostics mode!



Action	Key	Remark
Activate Diagnostics		Press any arrow key to call the selection menu. (Display color changes to turquoise.) Select DIAG using ◀ ▶ keys, confirm with enter
Select diagnostics option		Use ◀ ▶ keys to select from: CALDATA SENSOR SELFTEST LOGBOOK MONITOR VERSION See next pages for further proceeding.
End	meas	End with meas .





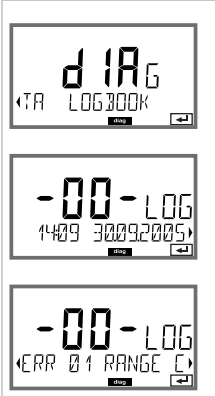

Diagnostics

Display	Menu item
	Display of calibration data Select CALDATA using ◀ ▶, confirm with enter . Use the ◀ ▶ keys to select the desired parameter from the bottom line of the display (LAST_CAL ISFET-ZERO ZERO SLOPE NEXT_CAL). The selected parameter is shown in the main display.
	
	
	
	Press meas to return to measurement.
	Display of sensor data For analog sensors, the type is displayed (STANDARD / ISFET). Not applicable for digital transmitters (-MSPH). For digital sensors, the manufacturer, type, serial number, and last calibration date is displayed. In each case Sensoface is active.
	Display data using ◀ ▶ keys, return with enter or meas .

Display	Menu item
	<p>Device self-test (To abort, you can press meas.)</p> <p>1) Display test: Display of all segments with changing background colors white/green/red. Proceed with enter</p>
	<p>2) RAM test: Hourglass blinks, then display of --PASS-- or --FAIL-- Proceed with enter</p>
	<p>3) EEPROM test: Hourglass blinks, then display of --PASS-- or --FAIL-- Proceed with enter</p>
	<p>4) FLASH test: Hourglass blinks, then display of --PASS-- or --FAIL-- Proceed with enter</p>
	<p>5) Module test: Hourglass blinks, then display of --PASS-- or --FAIL-- Press enter or meas to return to measuring mode.</p>

Diagnostics

Display	Menu item
	<p>Display of logbook entries Select LOGBOOK using ◀ ▶, confirm with enter.</p> <p>With the ▲ ▼ keys, you can scroll backwards and forwards through the logbook (entries -00-...-99-), -00- being the last entry.</p> <p>If the display is set to date/time, you can search for a particular date using the ▲ ▼ keys. Press ◀ ▶ to view the corresponding message text.</p> <p>If the display is set to the message text, you can search for a particular message using the ▲ ▼ keys. Press ◀ ▶ to display the date and time.</p> <p>Press meas to return to measurement.</p>
	<p>Extended logbook / Audit Trail (via TAN) With the ▲ ▼ keys, you can scroll backwards and forwards through the extended logbook (entries -000-...-199-), -000- being the last entry.</p> <p>Display: CFR Audit Trail also records function activations (CAL CONFIG SERVICE), some Sensoface messages (cal timer, wear), and opening of the enclosure.</p>

Display	Menu item
	<p>Display of currently measured values (sensor monitor)</p> <p>Select MONITOR using ◀ ▶, confirm with enter. Use the ◀ ▶ keys to select the desired parameter from the bottom line of the display: mV_PH mV_ORP RTD R_GLASS R_REF I-INPUT (for digital sensors also: OPERATION TIME SENSOR WEAR LIFETIME CIP SIP AUTOCLAVE). The selected parameter is shown in the main display.</p> <p>Press meas to return to measurement.</p>
Display example:	
	<p>Display mV_pH (for validation, sensor can be immersed in a calibration solution, for example, or the device is checked by using a simulator)</p>
	<p>Display of remaining dynamic lifetime (only for digital sensors, however not for MEMOSENS)</p>
	<p>Display of sensor operating time (for digital sensors only)</p>
	<p>Display of sensor wear (only for digital sensors of the InduCon type)</p>
	<p>Version</p> <p>Display of device type, software/hardware version, and serial number for all device components. Use the ▲ ▼ keys to switch between software and hardware version. Press enter to proceed to next device component.</p>



Service





In the Service mode you can access the following menus:

MONITOR	Displaying currently measured values
OUT1	Testing current output 1
OUT2	Testing current output 2
RELAY	Testing the function of the 4 relays
CONTROL	Testing the controller function
IRDA	Activating and communicating via the IrDA interface
CODES	Assigning and editing passcodes
DEFAULT	Resetting the device to factory settings
OPTION	Enabling options via TAN.

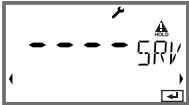

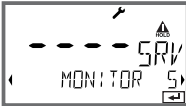

Please note:

HOLD is active during Service mode!

Action	Key/Display	Remark
Activate Service		Press any arrow key to call the selection menu. (Display color changes to green) Select SERVICE using ◀ ▶ keys, confirm with enter
Passcode		Enter passcode "5555" for service mode using the ▲ ▼ ◀ ▶ keys. Press enter to confirm.
Display		In service mode the following icons are displayed: <ul style="list-style-type: none">• HOLD triangle• Service (wrench)
End	meas	End with meas .

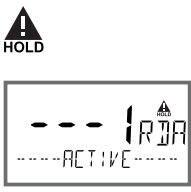
Menu item	Remark
 <p>Display example:</p>	<p>Display of currently measured values (sensor monitor) with HOLD mode activated: Select MONITOR using ◀ ▶, confirm with enter. Select variable in the bottom text line using ◀ ▶.</p> <p>The selected parameter is shown in the main display. As the device is in HOLD mode, you can perform validations using simulators without influencing the signal outputs.</p> <p>Press meas to return to the service menu. Return to measurement: Press meas once more.</p>
	<p>Specify current at outputs 1 and 2: Select OUT1 or OUT2 using the ◀ ▶ keys, confirm with enter. Enter a valid current value for the respective output using ▲ ▼ ◀ ▶ keys. Confirm with enter. For checking purposes, the actual output current is shown in the bottom right corner of the display. End with enter or meas.</p>
 	<p>Relay test (manual test of contacts): Select RELAIS using ◀ ▶, confirm with enter. Now the status of the 4 relays is "frozen". The 4 digits of the main display represent the respective states (from left to right: REL1, REL2, ALARM, WASH). The digit for the selected relay blinks. Select one of the 4 relays using the ◀ ▶ keys, close (1) or open (0) using the ▲ ▼ keys. End with enter. The relays will be re-set corresponding to the measured value.</p> <p>Press meas to return to measurement.</p>

Menu item	Remark
<div data-bbox="80 171 332 314" data-label="Image"> </div> <div data-bbox="80 355 262 419" data-label="Section-Header"> <h3>Controller characteristic</h3> </div> <div data-bbox="75 445 346 668" data-label="Figure"> <p>The diagram shows a vertical axis for 'Controller output Yp [%]' ranging from -100% to +100%. A horizontal line represents the 'Setpoint'. A 'Neutral zone Yp=0' is centered on the setpoint. 'Deviation Xw [mS/cm]' is shown as the difference between the setpoint and the measured value. 'Relay 1' is active for negative deviations (measured value < setpoint), and 'Relay 2' is active for positive deviations (measured value > setpoint).</p> </div> <div data-bbox="80 695 353 751" data-label="Text"> <p>The arrows indicate which relay (valve) is active:</p> </div> <div data-bbox="75 780 260 984" data-label="List-Group"> <ul style="list-style-type: none"> ▲ Relay 2 active (Meas. value > setpoint) ▼ Relay 2 active (Meas. value < setpoint) </div>	<div data-bbox="365 151 769 206" data-label="Section-Header"> <h3>Controller test (manual specification of controller output):</h3> </div> <div data-bbox="365 209 879 353" data-label="Text"> <p>This function is used to start up control loops or check the actuators. For bumpless changeover to automatic operation (exiting this function), configure an I-action component (reset time).</p> </div> <div data-bbox="365 384 852 439" data-label="Text"> <p>The lower display shows the currently adjusted controller output Yp.</p> </div> <div data-bbox="365 470 881 557" data-label="Text"> <p>Specify new value for controller output Yp: Enter sign and value in the main display using the ▲ ▼ ◀ ▶ keys. Press enter to confirm.</p> </div> <div data-bbox="365 588 836 615" data-label="Text"> <p>The new value is taken into the lower display.</p> </div> <div data-bbox="365 646 888 701" data-label="Text"> <p>Press enter or meas to return to the service menu. Return to measurement: Press meas once more.</p> </div> <div data-bbox="365 821 857 848" data-label="Text"> <p>Controller output -100...0% Relay 2 active</p> </div> <div data-bbox="365 908 823 936" data-label="Text"> <p>Controller output 0...+100% Relay 1 active</p> </div>

Menu item	Remark
	<p>IrDA communication: Select IRDA using ◀ ▶ , press enter to confirm.</p>
	<p>When IrDA communication is active, the device remains in the HOLD mode for reasons of safety. Further operation is performed via IrDA.</p> <p>End communication with meas.</p> <p>Exception: Firmware update (must not be interrupted!)</p>
	<p>Assigning passcodes: In the "SERVICE - CODES" menu you can assign passcodes to DIAG, HOLD, CAL, CONF, and SERVICE modes (Service preset to 5555).</p> <p>When you have lost the Service passcode, you have to request an "Ambulance TAN" from the manufacturer specifying the serial number of your device. To enter the "Ambulance TAN", call the Service function and enter passcode 7321. After correct input of the ambulance TAN the device signals "PASS" for 4 sec and resets the Service passcode to 5555.</p>
	<p>Reset to factory settings: In the "SERVICE - DEFAULT" menu you can reset the device to factory settings. CAUTION! All individual settings will be overwritten! Not affected: Calibration data</p>
	<p>Release of options: Options come with a "transaction number" (TAN). This TAN must be entered and confirmed using enter to release the option.</p>

Operating States

Operating status	OUT 1	OUT 2	REL1/2 (Limit)	REL1/2 (Control)	ALARM contact	WASH contact	Time out
Measuring							-
DIAG							60 s
CAL							No
CONF							20 min
SERVICE							20 min
SERVICE OUT 1							20 min
SERVICE OUT 2							20 min
SERVICE RELAY							20 min
SERVICE CONTROL							20 min
Cleaning fct							No
HOLD							No

Explanation: as configured (Last/Fix or Last/Off)

active

manual

Product Line and Accessories

Order Code Stratos Pro A 4...

						Channel 1	Channel 2	TAN
Example	A	4	1	1	N	- PH	/ 0	
4-wire / 20...254 V AC/DC	A	4						B,C,E
Communication								
Without (HART retrofittable via TAN)			0					A
HART			1					
Version number								
Version				1				
Approvals								
General Safety					N			
ATEX / IECEX / FM / CSA Zone 2 / Cl 1 Div 2					B			
Meas. channel 1 / Meas. channel 2								
Memosens pH (ORP)				Digital		MSPH	0	
Memosens pH (ORP) / pH (ORP)				Digital		MSPH	MSPH	
Memosens pH (ORP) / Oxy				Digital		MSPH	MSOXY	
Memosens COND				Digital		MSCOND	0	
Memosens COND / COND				Digital		MSCOND	MSCOND	
Memosens Oxy				Digital		MSOxy	0	
Dual COND (2x2-electrode, analog)				Module		CC	0	
pH / ORP value (ISM digital: TAN)				Module		PH	0	F
Cond, 2-/4-electrode				Module		COND	0	
Conductivity, electrodeless				Module		CONDI	0	
Oxygen (ISM digital/Traces: TAN)				Module		OXY	0	D, F
Carbon dioxide (ISM digital: TAN)				Module		CO2	0	F
TAN options								
HART						SW-A001		(A)
Logbook						SW-A002		(B)
Extended logbook (Audit Trail)						SW-A003		(C)
Trace oxygen measurement						SW-A004		(D)
Current input + 2 digital inputs						SW-A005		(E)
ISM digital						SW-A006		(F)
Mounting accessories								
Pipe-mount kit						ZU 0274		
Protective hood						ZU 0737		
Panel-mount kit						ZU 0738		

Specifications

pH input	Input for digital sensors (RS485)	
Display range	pH value	-2.00 ... 16.00
pH sensor standardization *	pH calibration	
Operating modes	BUF	Calibration with Calimatic automatic buffer recognition
	MAN	Manual calibration with input of individual buffer values
	DAT	Data entry of pre-measured electrodes
	Product calibration	
Calimatic buffer sets *	-00- Knick	2.00/4.01/7.00/9.21
	-01- Mettler-Toledo	2.00/4.01/7.00/9.21
	-02- Merck/Riedel	2.00/4.00/7.00/9.00/12.00
	-03- Ciba (94)	2.06/4.00/7.00/10.00
	-04- NIST technical	1.68/4.00/7.00/10.01/12.46
	-05- NIST standard	1.679/4.006/6.865/9.180
	-06- HACH	4.00/7.00/10.01
	-07- WTW techn. buffers	2.00/4.01/7.00/10.00
	-08- Hamilton	4.01/7.00/10.01
	-09- Reagecon	2.00/4.00/7.00/9.00/12.00
	-U1-	Specifiable buffer set with 2 buffer solutions
Zero adjustment	± 200 mV (for ISFET)	
Max. calibration range	Asymmetry potential	±60 mV
	Slope	80 ... 103 % (47,5 ... 61 mV/pH)
	(possibly restricting notes from Sensosface)	
ORP sensor standardization *	ORP calibration (zero adjustment)	
Max. calibration range	-700 ... +700 ΔmV	
Adaptive cal timer *	Interval 0000 ... 9999 h	
(Pat. DE 101 41 408)		
Sensocheck	Automatic monitoring of glass and reference electrode (can be disabled)	
Delay	Approx. 30 s	

Specifications

Sensoface	Provides information on the sensor condition, evaluation of zero/slope, response time, calibration interval, wear, Sensocheck, can be switched off
I input	Current input 0/4 ... 20 mA / 50 Ω for external temperature signal
Start/end of scale	Configurable within the measuring range for °C (°F)
Characteristic	Linear
Measurement error ^{1,3)}	< 1% current value + 0.1 mA
HOLD input	Galvanically separated (OPTO coupler)
Function	Switches device to HOLD mode
Switching voltage	0 ... 2 V (AC/DC) Inactive 10 ... 30 V (AC/DC) HOLD active
CONTROL input	Galvanically separated (OPTO coupler)
Function	Selecting parameter set A/B
Switching voltage	0 ... 2 V (AC/DC) Parameter set A 10 ... 30 V (AC/DC) Parameter set B
Output 1	0/4 ... 20 mA, max. 10 V, floating (galv. connected to output 2)
Process variable*	pH, ORP, or temperature
Characteristic	Linear
Overrange *	22 mA in the case of error messages
Output filter *	PT, filter, time constant 0 ... 120 s
Meas. error ^{1,2,3)}	< 0.25 % current value + 0.025 mA
Start/end of scale *	Configurable within the measuring ranges for pH, mV, °C, °F
Minimum span	pH 2.00 / 200 mV / 20 K / 36 °F

Output 2	0/4 ... 20 mA, max. 10 V, floating (galv. connected to output 1)	
Process variable*	pH, ORP, or temperature	
Characteristic	Linear	
Overrange*	22 mA in the case of error messages	
Output filter*	PT, filter, time constant 0 ... 120 s	
Meas. error ^{1,2,3)}	< 0.25 % current value + 0.025 mA	
Start/end of scale*	Configurable within the measuring ranges for pH, mV, °C, °F	
Minimum span	pH 2.00 / 200 mV / 20 K / 36 °F	
Alarm contact	Relay contact, floating	
Contact ratings	AC	< 250 V / < 3 A / < 750 VA
	DC	< 30 V / < 3 A / < 90 W
Contact response	N/C (fail-safe type)	
Response delay*	0000 ... 0600 sec	
Wash contact	Relay contact, floating	
	For controlling a cleaning system	
Contact ratings	AC	< 250 V / < 3 A / < 750 VA
	DC	< 30 V / < 3 A / < 90 W
Contact response*	N/C or N/O	
Interval*	000,0 ... 999.9 h (000.0 h = cleaning function switched off)	
Cleaning time*	0000 ... 1999 s	
or		
Parameter set A/B	For signaling parameter set A/B	
Contact ratings	AC	< 250 V / < 3 A / < 750 VA
	DC	< 30 V / < 3 A / < 90 W
Contact response	Contact open:	Parameter set A active
	Contact closed:	Parameter set B active

Specifications

Limit values REL1/REL2	REL1/REL2 contacts, floating, but inter-connected
Contact ratings	AC < 250 V / < 3 A / < 750 VA DC < 30 V / < 3 A / < 90 W
Contact response*	N/C or N/O
Response delay*	0000 ... 9999 s
Switching points*	As desired within range
Hysteresis*	User-defined
PID process controller	Output via REL1/REL2 relay contacts (see limit values)
Setpoint specification*	Within selected range
Neutral zone*	pH 0 ... 5 / 0 ... 500 mV / 0 ... 50 K
Proportional action*	Controller gain Kp: 0010 ... 9999 %
Integral action*	Reset time Tr: 0000 ... 9999 s (0000 s = no integral action)
Derivative action*	Rate time Td: 0000 ... 9999 s (0000 s = no derivative action)
Controller type*	Pulse length controller or pulse frequency controller
Pulse period*	0001 ... 0600 s, min. ON time 0.5 s (pulse length controller)
Max. pulse frequency*	0001 ... 0180 min ⁻¹ (pulse frequency controller)
Real-time clock	Different time and date formats selectable
Power reserve	> 5 days
Display	LC display, 7-segment with icons
Main display	Character height approx. 22 mm, unit symbols approx. 14 mm
Secondary display	Character height approx. 10 mm
Text line	14 characters, 14 segments
Sensoface	3 status indicators (friendly, neutral, sad face)

Mode indicators	meas, cal, conf, diag Further icons for configuration and messages
Alarm indication	Red backlighting in case of alarm
Keypad	Keys: meas, info, 4 cursor keys, enter
HART communication	HART version 6 Digital communication by FSK modulation of output current 1 Device identification, measured values, status and messages, parameter setting, calibration, records
Conditions	Output current ≥ 3.8 mA and load resistance $\geq 250 \Omega$
IrDA interface	Infrared interface for transmission of records and logbook, parameter setting, calibration, firmware update
FDA 21 CFR Part 11	Access control by editable passcodes Logbook entry and flag via HART in the case of configuration changes Message and logbook entry when enclosure is opened
Diagnostics functions	
Calibration data	Calibration date, zero, slope, response time
Device self-test	Displaytest, automatic memory test (RAM, FLASH, EEPROM), module test
Logbook	100 events with date and time
Extended logbook (TAN)	AuditTrail: 200 events with date and time
Service functions	
Sensor monitor	Display of direct sensor signals (mV/temperature/resistance ...)
Current source	Current specifiable for output 1 and 2 (00.00 ... 22,00 mA)
Relay test	Manual control of the four switching contacts
Manual controller	Controller output entered directly (start of control process)
IrDA	Activating the IrDA function

Specifications

Passcodes	Assigning passcodes for menu access
Factory setting	Resetting all parameters to factory setting Exception: Calibration data
TAN	Enabling optionally available additional functions
Data retention	Parameters, calibration data, logbook > 10 years (EEPROM)
EMC	EN 61326-1 (General Requirements)
Emitted interference	Class B (residential area)
Immunity to interference	Industry EN 61326-2-3 (Particular Requirements for Transmitters)
Explosion protection Stratos Pro A4...B MSPH (pending)	USA: FM CI I Div 2 / Zone 2 Canada: CSA CI I Div 2 / Zone 2
Power supply	24 (-15%) ... 230 (+10%) V AC/DC ⁶⁾ ; approx. 12 VA, 4 W AC: 45 ... 65 Hz Overvoltage category II, protection class II
Nominal operating conditions	
Ambient temperature	-20 ... +55 °C
Transport/Storage temp	-20 ... +70 °C
Relative humidity	10 ... 95% not condensing
Power supply	24 (-15%) ... 230 (+10%) V AC/DC (DC ≤ 80V)
Frequency for AC	45 ... 65 Hz
Enclosure	Molded enclosure made of PBT/PC, glass reinforced
Fastening	Wall, pipe/post, or panel mounting
Color	Gray, RAL 7001
Ingress protection	IP 67
Flammability	UL 94 V-0
Dimensions	148 mm x 148 mm
Control panel cutout	138 mm x 138 mm to DIN 43 700

Weight	1.2 kg (1.6 kg incl. accessories and packaging)
Cable glands	3 knockouts for M20 x 1.5 cable glands 2 knockouts for NPT ½" or rigid metallic conduit
Connections	Terminals, conductor cross section max. 2.5 mm ²

* User-defined

- 1) Acc. to EN 60746, at nominal operating conditions
- 2) ± 1 count
- 3) Plus sensor error
- 4) DC ≤ 80 V
- 5) At room temperature

Buffer Tables

- 00- Knick technical buffers (correspond to
- 01- Mettler-Toledo technical buffers)

°C	pH			
0	2.03	4.01	7.12	9.52
5	2.02	4.01	7.09	9.45
10	2.01	4.00	7.06	9.38
15	2.00	4.00	7.04	9.32
20	2.00	4.00	7.02	9.26
25	2.00	4.01	7.00	9.21
30	1.99	4.01	6.99	9.16
35	1.99	4.02	6.98	9.11
40	1.98	4.03	6.97	9.06
45	1.98	4.04	6.97	9.03
50	1.98	4.06	6.97	8.99
55	1.98	4.08	6.98	8.96
60	1.98	4.10	6.98	8.93
65	1.99	4.13	6.99	8.90
70	1.99	4.16	7.00	8.88
75	2.00	4.19	7.02	8.85
80	2.00	4.22	7.04	8.83
85	2.00	4.26	7.06	8.81
90	2.00	4.30	7.09	8.79
95	2.00	4.35	7.12	8.77

-02- Merck Titrisols, Riedel-de-Haen Fixanals

°C	pH				
0	2.01	4.05	7.13	9.24	12.58
5	2.01	4.04	7.07	9.16	12.41
10	2.01	4.02	7.05	9.11	12.26
15	2.00	4.01	7.02	9.05	12.10
20	2.00	4.00	7.00	9.00	12.00
25	2.00	4.01	6.98	8.95	11.88
30	2.00	4.01	6.98	8.91	11.72
35	2.00	4.01	6.96	8.88	11.67
40	2.00	4.01	6.95	8.85	11.54
45	2.00	4.01	6.95	8.82	11.44
50	2.00	4.00	6.95	8.79	11.33
55	2.00	4.00	6.95	8.76	11.19
60	2.00	4.00	6.96	8.73	11.04
65	2.00	4.00	6.96	8.72	10.97
70	2.01	4.00	6.96	8.70	10.90
75	2.01	4.00	6.96	8.68	10.80
80	2.01	4.00	6.97	8.66	10.70
85	2.01	4.00	6.98	8.65	10.59
90	2.01	4.00	7.00	8.64	10.48
95	2.01	4.00	7.02	8.64	10.37

Buffer Tables

-03- Ciba (94) buffers

Nominal values: 2.06 4.00 7.00 10.00

°C	pH			
0	2.04	4.00	7.10	10.30
5	2.09	4.02	7.08	10.21
10	2.07	4.00	7.05	10.14
15	2.08	4.00	7.02	10.06
20	2.09	4.01	6.98	9.99
25	2.08	4.02	6.98	9.95
30	2.06	4.00	6.96	9.89
35	2.06	4.01	6.95	9.85
40	2.07	4.02	6.94	9.81
45	2.06	4.03	6.93	9.77
50	2.06	4.04	6.93	9.73
55	2.05	4.05	6.91	9.68
60	2.08	4.10	6.93	9.66
65	2.07*	4.10*	6.92*	9.61*
70	2.07	4.11	6.92	9.57
75	2.04*	4.13*	6.92*	9.54*
80	2.02	4.15	6.93	9.52
85	2.03*	4.17*	6.95*	9.47*
90	2.04	4.20	6.97	9.43
95	2.05*	4.22*	6.99*	9.38*

* extrapolated

-04- NIST technical buffers

°C	pH				
0	1.67	4.00	7.115	10.32	13.42
5	1.67	4.00	7.085	10.25	13.21
10	1.67	4.00	7.06	10.18	13.01
15	1.67	4.00	7.04	10.12	12.80
20	1.675	4.00	7.015	10.06	12.64
25	1.68	4.005	7.00	10.01	12.46
30	1.68	4.015	6.985	9.97	12.30
35	1.69	4.025	6.98	9.93	12.13
40	1.69	4.03	6.975	9.89	11.99
45	1.70	4.045	6.975	9.86	11.84
50	1.705	4.06	6.97	9.83	11.71
55	1.715	4.075	6.97	9.83*	11.57
60	1.72	4.085	6.97	9.83*	11.45
65	1.73	4.10	6.98	9.83*	11.45*
70	1.74	4.13	6.99	9.83*	11.45*
75	1.75	4.14	7.01	9.83*	11.45*
80	1.765	4.16	7.03	9.83*	11.45*
85	1.78	4.18	7.05	9.83*	11.45*
90	1.79	4.21	7.08	9.83*	11.45*
95	1.805	4.23	7.11	9.83*	11.45*

* Values complemented

Buffer Tables

-05- NIST standard buffers
NIST Standard (DIN 19266 : 2000-01)

°C	pH			
0				
5	1.668	4.004	6.950	9.392
10	1.670	4.001	6.922	9.331
15	1.672	4.001	6.900	9.277
20	1.676	4.003	6.880	9.228
25	1.680	4.008	6.865	9.184
30	1.685	4.015	6.853	9.144
37	1.694	4.028	6.841	9.095
40	1.697	4.036	6.837	9.076
45	1.704	4.049	6.834	9.046
50	1.712	4.064	6.833	9.018
55	1.715	4.075	6.834	9.985
60	1.723	4.091	6.836	8.962
70	1.743	4.126	6.845	8.921
80	1.766	4.164	6.859	8.885
90	1.792	4.205	6.877	8.850
95	1.806	4.227	6.886	8.833

Please note:

The actual pH values of the individual batches of the reference materials are documented in a certificate of an accredited laboratory. This certificate is supplied with the respective buffers. Only these pH(S) values shall be used as standard values for the secondary reference buffer materials. Correspondingly, this standard does not include a table with standard pH values for practical use. The table above only provides examples of pH(PS) values for orientation.

-06- HACH buffers
Nominal values: 4.01 7.000 10.01 (± 0.02 at 25 °C)

°C	pH		
0	4.00	7.118	10.30
5	4.00	7.087	10.23
10	4.00	7.059	10.17
15	4.00	7.036	10.11
20	4.00	7.016	10.05
25	4.01	7.000	10.01
30	4.01	6.987	9.96
35	4.02	6.977	9.92
40	4.03	6.970	9.88
45	4.05	6.965	9.85
50	4.06	6.964	9.82
55	4.07	6.965	9.79
60	4.09	6.968	9.76
65	4.10*	6.98*	9.71*
70	4.12*	7.00*	9.66*
75	4.14*	7.02*	9.63*
80	4.16*	7.04*	9.59*
85	4.18*	7.06*	9.56*
90	4.21*	7.09*	9.52*
95	4.24*	7.12*	9.48*

* Values complemented

Buffer Tables

-07- WTW technical buffers

°C	pH			
0	2.03	4.01	7.12	10.65
5	2.02	4.01	7.09	10.52
10	2.01	4.00	7.06	10.39
15	2.00	4.00	7.04	10.26
20	2.00	4.00	7.02	10.13
25	2.00	4.01	7.00	10.00
30	1.99	4.01	6.99	9.87
35	1.99	4.02	6.98	9.74
40	1.98	4.03	6.97	9.61
45	1.98	4.04	6.97	9.48
50	1.98	4.06	6.97	9.35
55	1.98	4.08	6.98	
60	1.98	4.10	6.98	
65	1.99	4.13	6.99	
70	2.00	4.16	7.00	
75	2.00	4.19	7.02	
80	2.00	4.22	7.04	
85	2.00	4.26	7.06	
90	2.00	4.30	7.09	
95	2.00	4.35	7.12	

-08- Hamilton Duracal buffers

°C	pH		
0	4.01	7.12	10.23
5	4.01	7.09	10.19
10	4.00	7.06	10.15
15	4.00	7.04	10.11
20	4.00	7.02	10.06
25	4.01	7.00	10.01
30	4.01	6.99	9.97
35	4.02	6.98	9.92
40	4.03	6.97	9.86
45	4.04	6.97	9.83
50	4.05	6.97	9.79
55	4.06	6.98	9.75
60	4.08	6.98	9.72
65	4.10*	6.99*	9.69*
70	4.12*	7.00*	9.66*
75	4.14*	7.02*	9.59*
80	4.16*	7.04*	9.59*
85	4.18*	7.06*	9.56*
90	4.21*	7.09*	9.52*
95	4.24*	7.12*	9.48*

* Values complemented

Buffer Tables

-09- Reagecon buffers

°C	pH				
0°C	*2.01	*4.01	*7.07	*9.18	*12.54
5°C	*2.01	*4.01	*7.07	*9.18	*12.54
10°C	2.01	4.00	7.07	9.18	12.54
15°C	2.01	4.00	7.04	9.12	12.36
20°C	2.01	4.00	7.02	9.06	12.17
25°C	2.00	4.00	7.00	9.00	12.00
30°C	1.99	4.01	6.99	8.95	11.81
35°C	2.00	4.02	6.98	8.90	11.63
40°C	2.01	4.03	6.97	8.86	11.47
45°C	2.01	4.04	6.97	8.83	11.39
50°C	2.00	4.05	6.96	8.79	11.30
55°C	2.00	4.07	6.96	8.77	11.13
60°C	2.00	4.08	6.96	8.74	10.95
65°C	*2.00	*4.10	*6.99	*8.70	*10.95
70°C	*2.00	*4.12	*7.00	*8.67	*10.95
75°C	*2.00	*4.14	*7.02	*8.64	*10.95
80°C	*2.00	*4.16	*7.04	*8.62	*10.95
85°C	*2.00	*4.18	*7.06	*8.60	*10.95
90°C	*2.00	*4.21	*7.09	*8.58	*10.95
95°C	*2.00	*4.24	*7.12	*8.56	*10.95

* Values complemented

-U1- Specifiable Buffer Set

You can specify a buffer set with 2 buffer solutions in the temperature range of 0 ... 95 °C, step width: 5 °C.

To do so, select buffer set -U1- in the configuration menu.

As delivered, the Ingold technical buffer solutions pH 4.01 / 7.00 are stored as buffer set and can be edited.





Conditions for the specifiable buffer set:

- All values must lie in the range pH 0 ... 14
- Maximum difference between two adjacent pH values (5 °C step width) of the same buffer solution: pH 0.25
- The values of buffer solution 1 must be lower than those of buffer solution 2:
The difference between values for identical temperatures must be greater than 2 pH units.

Faulty entries are indicated in measuring mode by the "FAIL BUFFERSET -U1-" message.

The 25 °C value is always used for buffer display during calibration.

-U1- Specifiable Buffer Set

Step	Action/Display	Remark
Select buffer set -U1- (CONFIG / SNS menu)		
Select buffer solution 1 for editing	 <p>Select "YES" using up/down key.</p>	You are prompted for confirmation to prevent accidental changes of the settings.
Editing the values of buffer solution 1	 <p>Edit using arrow keys, press enter to confirm and proceed to next temperature value.</p> 	Enter the values for the first buffer solution in 5°C steps. The difference to the next value must not exceed 0.25 pH unit.
Select buffer solution 2 for editing		The difference between buffer solutions for identical temperatures must be greater than 2 pH units.

-U1- Specifiable Buffer Set

Buffer Set U1:

Fill in your configuration data or use the table as original for copy.

Temperature (°C)	Buffer 1	Buffer 2
5		
10		
15		
20		
25		
30		
35		
40		
45		
50		
55		
60		
65		
70		
75		
80		
85		
90		
95		

Error Handling

Alarm condition:

- The display backlighting turns **red**
- The alarm icon  is displayed
- The complete measured-value display blinks
- „**ERR xxx**“ is displayed in the lower menu line

Press the [**info**] key to view a short error text:

- The error text appears in the lower menu line
- The main display reads “**InFo**”.

Parameter errors:

Configuration data such as current range, limit values, etc are checked during the input.

If they are out of range,

- “**ERR xxx**“ is displayed for 3 sec,
- the display backlighting flashes red,
- the respective maximum or minimum value is shown,
- input must be repeated.

If a faulty parameter arrives through the interface (IrDA, HART),

- an error message will be displayed: “**ERR 100...199**“
- the faulty parameter can be localized by pressing the [**info**] key

Calibration errors:

If errors occur during calibration, e.g. by using a wrong calibration solution,

- an error message will be displayed
- calibration will be restarted

Sensoface:

If the Sensoface becomes sad,

- the display backlighting will turn purple
- the cause can be seen by pressing the **info** key
- the calibration data can be seen in the Diagnostics menu

Error Messages

Error	Info text (is displayed in case of fault when the Info key is pressed)	Problem Possible causes
ERR 99	DEVICE FAILURE	Error in factory settings EEPROM or RAM defective This error message only occurs in the case of a total defect. The device must be repaired and recalibrated at the factory.
ERR 98	CONFIGURATION ERROR	Error in configuration or calibration data Configuration or calibration data defective Reset device to factory settings (SERVICE/DEFAULT), then calibrate
ERR 97	NO MODULE INSTALLED	No module (Not for digital devices) Please have the module installed in the factory.
ERR 96	WRONG MODULE	Wrong module Please have the module replaced in the factory.
ERR 95	SYSTEM ERROR	System error Restart required. If error still persists, send in the device for repair.
ERR 01	NO SENSOR	pH sensor * Sensor defective Sensor not connected Break in sensor cable
ERR 02	WRONG SENSOR	Wrong sensor *
ERR 03	CANCELED SENSOR	Sensor devaluated *

Error Messages

Error	Info text (is displayed in case of fault when the Info key is pressed)	Problem Possible causes
ERR 04	SENSOR FAILURE	Failure in sensor *
ERR 05	CAL DATA	Error in cal data *
ERR 10	ORP RANGE	ORP display range violation < -1999 mV or > 1999 mV
ERR 11	PH RANGE	pH display range violation < -2 or > 16
ERR 12	MV RANGE	mV range
ERR 13	TEMPERATURE RANGE	Temperature range violation
ERR 15	SENSOCHECK GLASS-EL	Sensocheck glass
ERR 16	SENSOCHECK REF-EL	Sensocheck ref.
ERR 60	OUTPUT LOAD	Load error
ERR 61	OUTPUT 1 TOO LOW	Output current 1 < 3.8 mA
ERR 62	OUTPUT 1 TOO HIGH	Output current 1 > 20.5 mA
ERR 63	OUTPUT 2 TOO LOW	Output current 2 < 3.8 mA
ERR 64	OUTPUT 2 TOO HIGH	Output current 2 > 20.5 mA
ERR 69	TEMP. OUTSIDE TABLE	Temperature value outside table
ERR 100	INVALID SPAN OUT1	Configuration error Output range 1
ERR 101	INVALID SPAN OUT2	Configuration error Output range 2

Error	Info text (is displayed in case of fault when the Info key is pressed)	Problem Possible causes
ERR 102	FAILURE BUFFERSET -U1-	Configuration error Specifiable buffer set U1
ERR 104	INVALID PARAMETER CONTROLLER	Configuration error Controller
ERR 105	INVALID SPAN I-INPUT	Configuration error Current input
ERR 106 ...255	VOID PARAMETER	Invalid parameter

*) Digital sensors (ISM, InduCon, Memosens)

Sensoface

(Sensocheck must have been activated during configuration.)

The smiley in the display (Sensoface) alerts to sensor problems (defective sensor, sensor wear, defective cable, maintenance request). The permitted calibration ranges and the conditions for a friendly, neutral, or sad Sensoface are summarized in the following table. Additional icons refer to the error cause.

Sensocheck

Continuously monitors the sensor and its wiring.

Critical values make the Sensoface “sad” and the corresponding icon blinks:



The Sensocheck message is also output as error message Err 15 (glass electrode) or Err 16 (reference electrode – for digital transmitters, however only with InduCon sensors with SG). The alarm contact is active, the display backlighting turns red, output current 1 is set to 22 mA (when configured correspondingly).











Sensocheck can be switched off during configuration (then Sensoface is also disabled).

Exception:



After a calibration a smiley is always displayed for confirmation.

Please note:

The worsening of a Sensoface criterion leads to the devaluation of the Sensoface indicator (Smiley becomes “sad”). An improvement of the Sensoface indicator can only take place after calibration or removal of the sensor defect.

Display	Problem	Status
	Asymmetry potential and slope	 Asymmetry potential (zero) and slope of the sensor are still okay. The sensor should be replaced soon.
		 Asymmetry potential and slope of the sensor have reached values which no longer ensure proper calibration. Replace sensor.
	Calibration timer	 Over 80% of the calibration interval has already past.
		 The calibration interval has been exceeded.
	Sensor defect	 Check the sensor and its connections (see also Error Messages Err 15 and Err 16).
	Response time	 Sensor response time has increased. The sensor should be replaced soon. To achieve an improvement, clean the sensor and soak it in buffer.
		 Sensor response time significantly increased (> 72 s, calibration aborted after 120 s) Replace sensor.

Sensoface

Display	Problem	Status
	Sensor wear (for digital sensors only)	 High temperatures and pH values have caused a wear of over 80%. The sensor should be replaced soon.  Wear is at 100%. Replace sensor.

Conformity with FDA 21 CFR Part 11

In their directive “Title 21 Code of Federal Regulations, 21 CFR Part 11, Electronic Records; Electronic Signatures” the US American health agency FDA (Food and Drug Administration) regulates the production and processing of electronic documents for pharmaceutical development and production. This results in requirements for measuring devices used for corresponding applications. The following features ensure that the measuring devices of the M420 Series meet the demands of FDA 21 CFR Part 11:

Electronic Signature – Passcodes

Access to the device functions is regulated and limited by individually adjustable codes – “Passcodes” (see SERVICE). This prevents unauthorized modification of device settings or manipulation of the measurement results. Appropriate use of these passcodes makes them suitable as electronic signature.

Audit Trail

Every (manual) change of device settings can be automatically documented. Each change is tagged with a “Configuration Change Flag”, which can be interrogated and documented using HART communication. Altered device settings or parameters can also be retrieved and documented using HART communication.

Extended logbook

Audit Trail also records function activations (CAL, CONFIG, SERVICE), some Sensoface messages (cal timer, wear), and opening of the enclosure.

Index

A

- Access codes 139, 149
- Accessories 112
- Alarm 31
 - Alarm contact 61
 - Delay 60
- Ambulance TAN 109
- Application in hazardous locations 15
- Approvals for application in hazardous locations 9, 118
- Assembly 11
- Asymmetry potential 93
- Audit Trail 104, 139
- Automatic calibration (Calimatic) 88

B

- Backlighting 25
- Buffer tables 120

C

- Calibration 28, 84
 - Automatic calibration (Calimatic) 88
 - Calibration error 132
 - Calibration timer 47, 137
 - Configuration 44
 - Data entry of premeasured sensors 92
 - ISFET sensors 84
 - Manual calibration with buffer entry 90
 - Product calibration (pH) 94
 - Redox calibration 96
 - Temperature probe adjustment 98
 - Zero adjustment 87
- Calibration data 102
- Calibration error 132
- Calibration mode 45, 85
- Calimatic 88
- CD-ROM 3
- CIP 49
- Cleaning cycles 49

- Configuration 28
 - Alarm 60
 - Calibration mode 44
 - Calibration timer 46
 - Cleaning cycles 48
 - Controller 72
 - Current output 1 50
 - Current output 2 56
 - Individual configuration data 39, 131
 - Limit function 62
 - Menu groups 33
 - Menu structure 32
 - Output current during Error and HOLD 54
 - Overview 35
 - Sensocheck 60
 - Sensor 42
 - Sterilization cycles 48
 - Tag number 78
 - Temperature 42
 - Temperature compensation 58
 - Time and date 78
 - Time averaging filter 52
 - WASH contact 76
 - Connection examples 19
 - Controller
 - Configuration 72
 - Controller equations 70
 - Controller functions 69
 - Controller test 108
 - Manual specification of controller output 108
 - Controller characteristic 69
 - Converting Slope to mV 93
- D**
- Data entry of premeasured sensors 92
 - Date 79
 - Display 99
 - Device self-test 103

Index

- Device type, display 105
- Diagnostics 28, 101
 - Calibration data 102
 - Device self-test 103
 - Logbook 104
 - Sensor data 102
 - Sensor monitor 105
 - Version 105
- Digital sensors 80
 - Sensor type selection 43
- Dimensions 12
- Display 25
 - Display test 103
- Display backlighting 25
- Disposal 2
- Documentation 3

E

- EEPROM test 103
- Electrical installation 9
- Electronic Signature 139
- Enabling options 109
- Enclosure 12
- Enclosure components 11
- Entering values 27
- Error handling 132
- Error messages 133
- Explosion protection 118
- Extended logbook 104, 139
- External temperature measurement 59

F

- FDA 21 CFR Part 11 139
- FLASH test 103

H

- HOLD 28, 30
 - Controller behavior during HOLD 74
 - End 30
 - External activation of HOLD 31
 - Manual activation of HOLD 31
 - Output signal during HOLD 30, 55
 - Output signal response 30
- Hysteresis 65, 67

I

- Info text 133
- Installation 15
 - Safety information 9
- Intended use 7
- IrDA communication 109

K

- Keypad 24

L

- Limit 1 62
- Limit 2 66
- Logbook 104

M

- Manual calibration with buffer entry 90
- Measured values, display 105
- Measurement 99
- Measuring 26
- Memosens 80
 - Connection 81
 - Sensor replacement 82
 - Wiring example 21
- Menu structure 29
 - Configuration 32
- Module test 103
- Mounting plan 12

O

- Operating modes 28
- Operating mode, selection 27
- Operating states 110
- Options 109, 112
- Order code 112
- ORP calibration 96
- Output current, fixed value 107
- Output current range 50, 56
- Output filter 52
- Output signal during HOLD 30, 55
- Overview 10

P

- Package contents 3, 11
- Panel mounting 14
- Parameter error 132
- Parameter set A/B 33
 - Display 99
 - Display via WASH contact 34
 - Individual configuration data 39
 - Manual selection 34
- Passcodes 139, 149
 - Setting 109
- PFC 71
- Pipe mounting 13
- PLC 71
- Point of measurement (TAG) 79
- Power supply 17, 118
- Presetting pH calibration 85
- Process variable 51, 57
- Product calibration 94
- Product line 112
- Protective hood 13
- Protective wiring 22
- Pulse frequency controller (PFC) 71
 - Configuration 73
- Pulse length controller (PLC) 71
 - Configuration 73

R

- RAM test 103
- Rating plates 16
- Redox calibration 96
- Relay 1 62
- Relay 2 66
- Relay test 107
- Release of options 109
- Reset to factory settings 109
- Return of products under warranty 2

S

- Safety information 7, 8
- Safety instructions 3
- Selection menu 27
- Sensocheck 60, 136
 - Configuration 61
- Sensoface 132, 136
- Sensor connection 18, 19
- Sensor data, display 102
- Sensor defect 137
- Sensor monitor 105, 107
- Sensor type selection 42
- Sensor wear 138
- Serial number, display 105
- Service 28, 106
 - Controller test 108
 - Factory setting 109
 - IrDA communication 109
 - Passcodes 109
 - Relay test 107
 - Releasing options 109
 - Sensor monitor 107
 - Specifying current outputs 107
- Service passcode lost 109
- Signal colors 25
- Signal lines 17
- SIP 49
- Software version, display 105

Index

Specifications 113
Start-up 8
Sterilization cycles 49

T

TAG 79
TAN options 112
 Releasing 109
Temperature compensation 59
Temperature dependence of reference systems measured
 against SHE 96
Temperature detection 42
 for calibration 45
 Temp specification via current input 43, 59
Temperature probe adjustment 98
Terminal assignments 16
Terminals 9, 15, 16
Time 79
 Display 99
Time averaging filter 53
Trademarks 9

U

User interface 24

W

Warranty 2
WASH contact
 Configuration 76
 parameter set 34
Wiring 17
 Examples 19

Z

Zero adjustment (ISFET) 86

Passcodes

In the SERVICE – CODES menu you can assign passcodes to protect the access to certain functions.

Operating Mode	Passcode
Service (SERVICE)	5555
Diagnostics (DIAG)	
HOLD mode	
Calibration (CAL)	
Configuration (CONF)	

Knick Elektronische Messgeräte GmbH & Co. KG

P.O. Box 37 04 15
D-14134 Berlin

Phone: +49 (0)30 - 801 91 - 0
Fax: +49 (0)30 - 801 91 - 200
Internet: <http://www.knick.de>
knick@knick.de

