

# 1066 Liquid Analytical Transmitter



# Essential Instructions

## Read this page before proceeding

Emerson designs, manufactures, and tests its Rosemount Analytical products to meet many national and international standards. Because these instruments are sophisticated technical products, you must properly install, use, and maintain them to ensure they continue to operate within their normal specifications. The following instructions must be adhered to and integrated into your safety program when installing, using, and maintaining Rosemount Analytical products. Failure to follow the proper instructions may cause any one of the following situations to occur: Loss of life; personal injury; property damage; damage to this instrument; and warranty invalidation.

- Read all instructions prior to installing, operating, and servicing the product. If this Instruction Manual is not the correct manual, telephone 1-800-854-8257 and the requested manual will be provided. Save this Instruction Manual for future reference.
- If you do not understand any of the instructions, contact your Emerson representative for clarification.
- Follow all warnings, cautions, and instructions marked on and supplied with the product.
- Inform and educate your personnel in the proper installation, operation, and maintenance of the product.
- Install your equipment as specified in the Installation Instructions of the appropriate Instruction Manual and per applicable local and national codes. Connect all products to the proper electrical and pressure sources.
- To ensure proper performance, use qualified personnel to install, operate, update, program, and maintain the product.
- When replacement parts are required, ensure that qualified people use replacement parts specified by Rosemount. Unauthorized parts and procedures can affect the product's performance and place the safe operation of your process at risk. Look alike substitutions may result in fire, electrical hazards, or improper operation.
- Ensure that all equipment doors are closed and protective covers are in place, except when maintenance is being performed by qualified persons, to prevent electrical shock and personal injury.

### **WARNING: EXPLOSION HAZARD**

**DO NOT OPEN WHILE CIRCUIT IS LIVE. ONLY CLEAN WITH DAMP CLOTH.**

### **NOTICE**

**If a 475 Universal HART® Communicator is used with these transmitters, the software within the 475 may require modification. If a software modification is required, please contact your local Emerson Process Management Service Group or National Response Center at 1-800-654-7768.**

#### **Electrostatic ignition hazard.**

#### **Special condition for safe use (when installed in hazardous area)**

The plastic enclosure, excepting the front panel, must only be cleaned with a damp cloth.

## About this document

This manual contains instructions for installation and operation of the 1066 Smart Transmitter. The following list provides notes concerning all revisions of this document.

<b>Rev. Level</b>	<b>Date</b>	<b>Notes</b>
A	1/2012	This is the initial release of the product manual. The manual has been reformatted to reflect the Emerson documentation style and updated to reflect any changes in the product offering.
B	3/2012	This product manual version adds specifications and instrument instructions for Contacting Conductivity, Toroidal Conductivity, Chlorine, Oxygen, and Ozone measurements.

# Contents

## Section 1: Quick Start Guide

1.1	Quick start guide .....	1
-----	-------------------------	---

## Section 2: Description and Specifications

2.1	Features and Applications .....	2
2.2	General specifications.....	3
2.3	pH/ORP .....	3
2.3.1	Performance Specifications - Transmitter (pH input) .....	5
2.3.2	Performance Specifications - Transmitter (ORP input) .....	5
2.4	Contacting Conductivity (Codes – C) .....	6
2.4.1	Performance Specifications .....	6
2.4.2	Recommended Sensors for Conductivity .....	7
2.5	Toroidal Conductivity (Codes – T) .....	7
2.5.1	Performance Specifications .....	7
2.5.2	Recommended Sensors for Conductivity .....	8
2.6	Chlorine (Codes – CL) .....	8
2.6.1	Free and Total Chlorine .....	8
2.6.2	Performance Specifications .....	8
2.6.3	Recommended Sensors .....	8
2.6.4	Monochloramine .....	8
2.6.5	Performance Specifications .....	9
2.6.6	Recommended Sensors .....	9
2.7	Dissolved Oxygen (Codes – DO) .....	9
2.7.1	Free and Total Chlorine .....	9
2.7.2	Performance Specifications .....	9
2.8	Dissolved Oxygen (Codes – DO) .....	9
2.8.1	Free and Total Chlorine .....	9
2.8.2	Performance Specifications .....	9
2.9	Ordering Information .....	10

## Section 3: Installation

3.1	Unpacking and Inspection .....	11
3.2	Installation – general information .....	11
3.3	Preparing conduit openings .....	11

## Section 4: Wiring

4.1	General .....	14
4.1.1	General Information .....	14
4.1.2	Digital Communication .....	14
4.2	Power Supply/Current Loop – 1066-HT .....	14

- 4.2.1 Power Supply and Load Requirements ..... 14
- 4.2.2 Power Supply-Current Loop Wiring ..... 15
- 4.2.3 Current Output wiring..... 16
- 4.3 Power Supply Wiring For 1066-FF..... 16
  - 4.3.1 Power Supply Wiring ..... 16
- 4.4 Sensor Wiring to Main Board ..... 18

## Section 5: Intrinsically Safe Installation

- 5.1 All Intrinsically Safe Installations ..... 22

## Section 6: Display and operation

- 6.1 User Interface ..... 27
- 6.2 Instrument Keypad..... 27
- 6.3 Main Display ..... 28
- 6.4 Menu System..... 28

## Section 7: Programming – Basics

- 7.1 General..... 30
- 7.2 Changing the Startup Settings ..... 30
  - 7.2.1 Purpose ..... 30
  - 7.2.2 Procedure..... 31
- 7.3 Choosing Temperature Units & Automatic/Manual Temperature Compensation..... 31
  - 7.3.1 Purpose ..... 31
  - 7.3.2 Procedure..... 31
- 7.4 Contacting Conductivity Calibration..... 31
  - 7.4.1 Purpose ..... 31
  - 7.4.2 Definitions..... 32
  - 7.4.3 Procedure: Configure Outputs ..... 32
  - 7.4.4 Procedure: Assigning Measurements the Low and High Current Outputs .... 32
  - 7.4.4 Procedure: Ranging the Current Outputs..... 32
- 7.5 Setting a Security Code ..... 32
  - 7.5.1 Purpose ..... 32
  - 7.5.2 Procedure..... 33
- 7.6 Security Access..... 34
  - 7.6.1 How the Security Code Works..... 34
  - 7.6.2 Procedure..... 34
- 7.7 Using Hold..... 34
  - 7.7.1 Purpose ..... 34
  - 7.7.2 Using the Hold Function..... 34
- 7.8 Resetting Factory Default Settings ..... 34
  - 7.8.1 Purpose ..... 35
  - 7.8.2 Procedure..... 35

## Section 8: Programming – Measurements

8.1	Introduction .....	36
8.2	pH Measurement Programming .....	37
8.2.1	Description.....	37
8.2.2	Mearurement .....	37
8.2.3	Preamp.....	37
8.2.4	Solution Temperature Correction .....	38
8.2.5	Temperature Coefficient .....	38
8.2.6	Resolution .....	38
8.2.7	Filter .....	38
8.2.8	Reference Impedance.....	38
8.3	ORP Measurement Programming .....	38
8.3.1	Mearurement .....	39
8.3.2	Preamp.....	39
8.3.3	Filter .....	39
8.3.4	Reference Impedance.....	39
8.4	Contacting Conductivity .....	40
8.4.1	Description.....	40
8.4.2	Sensor Type .....	40
8.4.3	Measure .....	41
8.4.4	Range .....	41
8.4.5	Cell Constant .....	41
8.4.6	RTD Offset.....	41
8.4.7	RTD Slope.....	41
8.4.8	Temp Comp .....	41
8.4.9	Slope .....	42
8.4.10	Reference Temp .....	42
8.4.11	Filter .....	42
8.4.12	Custom Setup .....	42
8.4.13	Cal Factor .....	42
8.5	Toroidal Conductivity .....	43
8.5.1	Description.....	43
8.5.2	Sensor Type .....	43
8.5.3	Measure .....	44
8.5.4	Range .....	44
8.5.5	Cell Constant .....	44
8.5.6	Temp Comp .....	44
8.5.7	Slope .....	44
8.5.8	Reference Temp .....	45
8.5.9	Filter .....	45
8.5.10	Custom Setup .....	45
8.6	Chlorine Measurement.....	46
8.6.1	Free Chlorine .....	46

8.6.1.1	Measure	47
8.6.1.2	Units	47
8.6.1.3	Filter	47
8.6.1.4	Free Chlorine pH Correction	47
8.6.1.5	Manual pH Correction	47
8.6.1.6	Resolution	47
8.6.2	Total Chlorine	48
8.6.2.1	Description	48
8.6.2.2	Measure	48
8.6.2.3	Units	48
8.6.2.4	Filter	48
8.6.2.5	Resolution	49
8.6.3	Monochloramine	49
8.6.3.1	Measure: Monochloramine	49
8.6.3.2	Units	50
8.6.3.3	Filter	50
8.6.3.4	Resolution	50
8.7	Oxygen	50
8.7.1	Oxygen Measurement Application	51
8.7.2	Units	51
8.7.3	Partial Press.	51
8.7.4	Salinity	51
8.7.5	Filter	51
8.7.6	Pressure Units	51
8.8	Ozone	52
8.8.1	Units	52
8.8.2	Filter	52
8.8.3	Resolution	52

## Section 9: Calibration

9.1	Introduction	58
9.2	Calibration	58
9.2.1	Auto Calibration	59
9.2.2	Manual Calibration – pH	60
9.2.3	Entering a Known Slope Value – pH	60
9.2.4	Standardization – pH	60
9.3	ORP Calibration	61
9.3.1	Standardization – ORP	61
9.4	Contacting Conductivity Calibration	62
9.4.1	Entering the Cell Constant	63
9.4.2	Zeroing the Instrument	63
9.4.3	Calibrating the Sensor in a Conductivity Standard (in process cal)	63

9.4.4	Calibrating the Sensor To A Laboratory Instrument (meter cal) .....	64
9.4.5	Cal Factor .....	64
9.5	Toroidal Conductivity Calibration .....	65
9.5.1	Entering the Cell Constant.....	65
9.5.2	Zeroing the Instrument .....	66
9.5.3	Calibrating the Sensor in a Conductivity Standard (in process cal) .....	66
9.6	Calibration – Chlorine.....	67
9.6.1	Calibration – Free Chlorine .....	67
9.6.1.1	Zeroing the Sensor.....	68
9.6.1.2	In Process Calibration.....	68
9.6.1.3	Units .....	68
9.6.2	Calibration – Total Chlorine.....	68
9.6.2.1	Zeroing the Sensor.....	69
9.6.2.2	In Process Calibration.....	69
9.6.2.3	Units .....	69
9.6.3	Calibration – Monochloramine .....	70
9.6.4	Zeroing the Sensor .....	71
9.6.5	In Process Calibration .....	71
9.7	Calibration – Chlorine.....	71
9.7.1	Zeroing the Sensor .....	73
9.7.2	Calibrating the Sensor in Air .....	73
9.7.3	Calibrating the Sensor Against A Standard Instrument (in process cal) .....	74
9.8	Calibration – Ozone.....	74
9.8.1	Zeroing the Sensor .....	75
9.8.2	In Process Calibration .....	75
9.9	Calibrating Temperature .....	76
9.9.1	Calibration.....	76

## Section 10: Return of Material

10.1	General.....	84
10.2	Warranty Repair .....	84
10.3	Non-Warranty Repair .....	84



# Section 1: Quick Start Guide

## 1.1

1. For mechanical installation instructions, see page 8 for panel mounting and page 9 for pipe or wall mounting.
2. Wire the sensor to the main circuit board. See page 14 for wiring instructions. Refer to the sensor instruction sheet for additional details. Make loop power connections.
3. Once connections are secured and verified, apply DC power to the transmitter.
4. When the transmitter is powered up for the first time, Quick Start screens appear. Quick Start operating tips are as follows:
  - a. A highlighted field shows the position of the cursor.
  - b. To move the cursor left or right, use the keys to the left or right of the ENTER key. To scroll up or down or to increase or decrease the value of a digit use the keys above and below the ENTER key. Use the left or right keys to move the decimal point.
  - c. Press ENTER to store a setting. Press EXIT to leave without storing changes. Pressing EXIT during Quick Start returns the display to the initial start-up screen (select language).
5. Choose the desired language and press ENTER.
6. Choose measurement and press ENTER.
  - a. For pH, choose preamplifier location. Select Analyzer to use the integral preamplifier in the transmitter; select Sensor/J-Box if your sensor is SMART or has an integral preamplifier or if you are using a remote preamplifier located in a junction box.
5. If applicable, choose units of measurement.
6. For contacting and toroidal conductivity, choose the sensors type and enter the numeric cell constant using the keys.
7. Choose temperature units: °C or °F.
8. After the last step, the main display appears. The outputs are assigned to default values.
9. To change output settings, to scale the 4-20mA current outputs, to change measurement-related settings from the default values, and to enable pH diagnostics, press MENU. Select Program and follow the prompts. Refer to the appropriate menu.
10. To return the transmitter to the factory default settings, choose Program under the main menu, and then scroll to Reset.
11. Please call the Rosemount Analytical Customer Support Center at 1-800-854-8257 if you need further support.

## Section 2: Description and Specifications

### 2.1 Features and Applications

This loop-powered multi-parameter unit serves industrial, commercial and municipal applications with the widest range of liquid measurement inputs available for a two-wire liquid transmitter.

The 1066 Smart transmitter supports continuous measurement of one liquid analytical input. The design supports easy internal access and wiring connections.

**ANALYTICAL INPUTS:** Ordering options for pH/ORP, Resistivity/Conductivity, % Concentration, Total Chlorine, Free Chlorine, Monochloramine, Dissolved Oxygen, and Ozone.

**LARGE DISPLAY:** The high-contrast LCD provides live measurement readouts in large digits and shows up to four additional variables or diagnostic parameters.

**DIGITAL COMMUNICATIONS:** HART® version 7 digital communications are standard on 1066.

**MENUS:** Menu screens for calibrating and programming are simple and intuitive. Plain language prompts and help screens guide the user through the procedures. All menu screens are available in eight languages. Live process values are displayed during programming and calibration.

**QUICK START PROGRAMMING:** Popular Quick Start screens appear the first time the unit is powered. The instrument prompts the user to configure the sensor loop in a few quick steps for immediate commissioning.

**USER HELP SCREENS:** Fault and warning messages include help screens similar to PlantWeb™ alerts that provide useful troubleshooting tips to the user. These on-screen instructions are intuitive and easy to use.

**DIAGNOSTICS:** The transmitter continuously monitors itself and the sensor for problems. A display banner on the screen alerts Technicians to Fault and/or Warning conditions.

**LANGUAGES:** Rosemount Analytical extends its worldwide reach by offering eight languages – English, French, German, Italian, Spanish, Portuguese, Chinese and Russian.

**CURRENT OUTPUTS:** HART units include two 4-20 mA electrically isolated current outputs giving the ability to transmit the live measurement value and the process temperature reported from the sensor.

**INPUT DAMPENING:** is automatically enabled to suppress noisy process readings.

**SMART-ENABLED pH:** Rosemount Analytical's SMART pH capability eliminates field calibration of pH probes through automatic upload of calibration data and history.

**AUTOMATIC TEMPERATURE COMPENSATION:** Most measurements require temperature compensation. The 1066 will automatically recognize Pt100, Pt1000 or 22k NTC RTDs built into the sensor.

**SMART WIRELESS THUM ADAPTOR COMPATIBLE:** Enable wireless transmissions of process variables and diagnostics from hard-to-reach locations.

## 2.2 Specifications - General

**Case:** Polycarbonate. IP66 (CSA, FM), NEMA 4X (CSA)

**Dimensions:** Overall 155 x 155 x 131mm (6.10 x 6.10 x 5.15 in.). Cutout: 1/2 DIN 139mm x 139mm (5.45 x 5.45 in.)

**Conduit openings:** Six. Accepts PG13.5 or 1/2 in. conduit fittings

**Display:** Monochromatic graphic liquid crystal display. No backlight. 128 x 96 pixel display resolution. Active display area: 58 x 78mm (2.3 x 3.0 in.). All fields of the main instrument display can be customized to meet user requirements.

**Ambient temperature and humidity:** -20 to 65°C (-4 to 149°F), RH 5 to 95% (non-condensing).

**Storage Temperature:** -20 to 70°C (-4 to 158°F)

**HART® Communications:** PV, SV, TV, and 4V assignable to measurement, temperature and all live HART diagnostics.

**RFI/EMI:** EN-61326 

### Complies with the following Standards:

CSA: C22.2 No 0 – 10; C22.2 No 0.4 – 04; C22.2 No. 25-M1966; , C22.2 No. 94-M1991; , C22.2 No.142-M1987; , C22.2 No. 157-M1992; , C22.2 No. 213-M1987; , C22.2 No. 60529:05

ATEX: IEC 60079-0:2011, 60079-11:2011

IECEx: IEC 60079-0: 2011 Edition: 6.0, IEC 60079-11 : 2011-06 Edition: 6.0



FM: 3600: 1998, 3610: 2010, 3611: 2004, 3810: 2005, IEC 60529:2004, ANSI/IEC 60529

### Hazardous Location Approvals

Intrinsic Safety (with appropriate safety barrier):

 Class I, II, III, Div. 1  
Groups A-G  
T4 Tamb = -20°C to 65°C

 IECEx BAS 11.90098X  
EEx ia IIC  
T4 Tamb = -20°C to 65°C

 ATEX  1180 II 1 G  
Baseefa04ATEX0195X  
EEx ia IIC  
T4 Tamb = -20°C to 65°C

Non-Incendive:

 Class I, Div. 2, Groups A-D  
Dust Ignition Proof  
Class II & III, Div. 1, Groups E-G  
NEMA 4/4X Enclosure  
T4 Tamb = -20°C to 65°C

**Input:** One isolated sensor input. Measurement choices of pH/ORP, resistivity/conductivity/TDS, % concentration, total and free chlorine, monochloramine, dissolved oxygen, dissolved ozone, and temperature. For contacting conductivity measurements, temperature element can be a PT1000 RTD or a PT100 RTD. Other measurements (except ORP) and use PT100 or PT1000 RTDs or a 22k NTC (D.O. only).

**Power & Load Requirements:** Supply voltage at the transmitter terminals should be at least 12.7Vdc. Power supply voltage should cover the voltage drop on the cable plus the external load resistor required for HART communications (250 Ω minimum). Minimum power supply voltage is 12.7Vdc. Maximum power supply voltage is 42.4 Vdc (30 Vdc for intrinsically safe operation). The graph shows the supply voltage required to maintain 12 Vdc (upper line) and 30 Vdc (lower line) at the transmitter terminals when the current is 22 mA.

**FIGURE 2-1. Load/Power Supply Requirements**

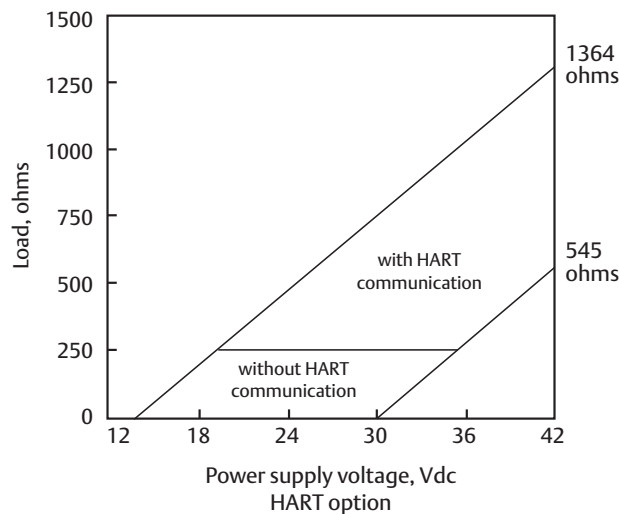

**Analog Outputs:** Two-wire loop powered (Output 1 only). Two 4-20 mA electrically isolated current outputs (Output 2 must be externally powered). Superimposed HART digital signal on Output 1. Fully scalable over the operating range of the sensor.

**Weight/Shipping Weight:** 2 lbs/3 lbs (1 kg/1.5 kg)

## 2.3 pH/ORP (Ordering Code – P)

For use with any standard pH or ORP sensor. SMART pH sensor with SMART pre-amplifiers from Rosemount Analytical. Measurement choices are pH, ORP, or Redox. The automatic buffer recognition feature uses stored buffer values and their temperature curves for the most common buffer standards available worldwide. The transmitter will recognize the value of the buffer being measured and perform a self stabilization check on the sensor before completing the calibration. Manual or automatic temperature compensation is menu selectable. Change in pH due to process temperature can be compensated using a programmable temperature coefficient.

### 2.3.1 Performance Specifications - Transmitter (pH input)

**Measurement Range [pH]:** 0 to 14 pH

**Accuracy:**  $\pm 0.01$  pH

**Buffer recognition:** NIST, DIN 19266, JIS 8802, and BSI.

**Input filter:** Time constant 1 - 999 sec, default 4 sec.

**Response time:** 5 seconds to 95% of final reading

**Recommended Sensors for pH:**

All standard pH sensors. Supports SMART pH sensors from Rosemount Analytical

### 2.3.2 Performance Specifications - Transmitter (ORP input)

**Measurement Range [ORP]:** -1400 to +1400 mV

**Accuracy:**  $\pm 1$  mV

**Input filter:** Time constant 1 - 999 sec, default 4 sec.

**Response time:** 5 seconds to 95% of final reading

**Recommended Sensors for ORP:** All standard ORP sensors

---

**FIGURE 2-2. General purpose and high performance pH sensors 3900, 396PVP and 3300HT**



## 2.4 Contacting Conductivity (Codes – C)

Measures conductivity in the range 0 to 600,000  $\mu\text{S}/\text{cm}$  (600mS/cm). Measurement choices are conductivity, resistivity, total dissolved solids, salinity, and % concentration. In addition, the “Custom Curve” feature allows users to define a three to five point curve to measure ppm, %, or a no unit variable. The % concentration selection includes the choice of five common solutions (0-12% NaOH, 0-15% HCl, 0-20% NaCl, and 0-25% or 96-99.7%  $\text{H}_2\text{SO}_4$ ). The conductivity concentration algorithms for these solutions are fully temperature compensated. Three temperature compensation options are available: manual slope ( $X\%/^{\circ}\text{C}$ ), high purity water (dilute sodium chloride), and cation conductivity (dilute hydrochloric acid). Temperature compensation can be disabled, allowing the transmitter to display raw conductivity. For more information concerning the use of the contacting conductivity sensors, refer to the product data sheets.

Note: The 410VP 4-electrode high-range conductivity sensor is compatible with the 1066.

### 2.4.1 Performance Specifications

**Measurement Range:**

Temperature range	0-200°C
Temperature Accuracy, Pt-1000, 0-50°C	$\pm 0.1^{\circ}\text{C}$
Temperature Accuracy, Pt-1000, Temp. > 50°C	$\pm 0.5^{\circ}\text{C}$

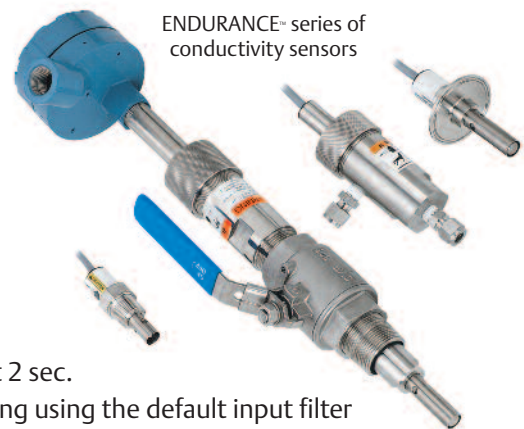

**Input filter:** Time constant 1 - 999 sec, default 2 sec.

**Response time:** 3 seconds to 95% of final reading using the default input filter

**Salinity:** Uses Practical Salinity Scale

**Total Dissolved Solids:** Calculated by multiplying conductivity at 25°C by 0.65

**TABLE 2-1. Performance Specifications: Recommended Range – Contacting Conductivity**

Cell Constant	0.01 $\mu\text{S}/\text{cm}$	0.1 $\mu\text{S}/\text{cm}$	1.0 $\mu\text{S}/\text{cm}$	10 $\mu\text{S}/\text{cm}$	100 $\mu\text{S}/\text{cm}$	1000 $\mu\text{S}/\text{cm}$	10mS/cm	100mS/cm	1000mS/cm
0.01	0.01 $\mu\text{S}/\text{cm}$ to 200 $\square\text{S}/\text{cm}$					200 $\mu\text{S}/\text{cm}$ to 6000 $\mu\text{S}/\text{cm}$			
0.1	0.1 $\mu\text{S}/\text{cm}$ to 2000 $\square\text{S}/\text{cm}$					2000 $\mu\text{S}/\text{cm}$ to 60mS/cm			
1.0	1 $\mu\text{S}/\text{cm}$ to 20mS/cm					20mS/cm to 600mS/cm			
4-electrode	2 $\mu\text{S}/\text{cm}$ to 300mS/cm								

**Cell Constant Linearity**

- $\pm 0.6\%$  of reading in recommended range
- +2 to -10% of reading outside high recommended range
- $\pm 5\%$  of reading outside low recommended range
- $\pm 4\%$  of reading in recommended range

## 2.4.2 Recommended Sensors for Conductivity

All Rosemount Analytical ENDURANCE 400 series conductivity sensors (Pt 1000 RTD) and 410VP 4-electrode sensor.

## 2.5 Toroidal Conductivity (Codes – T)

Measures conductivity in the range of 1  $\mu\text{S}/\text{cm}$  to 2,000,000  $\mu\text{S}/\text{cm}$  (2 S/cm). Measurement choices are conductivity, resistivity, total dissolved solids, salinity, and % concentration. The % concentration selection includes the choice of five common solutions (0-12% NaOH, 0-15% HCl, 0-20% NaCl, and 0-25% or 96-99.7%  $\text{H}_2\text{SO}_4$ ). The conductivity concentration algorithms for these solutions are fully temperature compensated. For other solutions, a simple-to-use menu allows the customer to enter his own data. The transmitter accepts as many as five data points and fits either a linear (two points) or a quadratic function (three to five points) to the data. Reference temperature and linear temperature slope may also be adjusted for optimum results. Two temperature compensation options are available: manual slope (X%/°C) and neutral salt (dilute sodium chloride). Temperature compensation can be disabled, allowing the transmitter to display raw conductivity. For more information concerning use of the toroidal conductivity sensors, refer to the product data sheets.

### 2.5.1 Performance Specifications

#### Measurement Range:

Temperature range	-25 to 210°C (-13 to 410°F)
Temperature Accuracy, Pt-100, -25 to 50°C	$\pm 0.5^\circ\text{C}$
Temperature Accuracy, Pt-100, 50 to 210°C	$\pm 1^\circ\text{C}$

High performance 225 Toroidal & 226 Conductivity sensors



TABLE 2-2. Performance Specifications: Recommended Range – Toroidal Conductivity

Model	1 $\mu\text{S}/\text{cm}$	10 $\mu\text{S}/\text{cm}$	100 $\mu\text{S}/\text{cm}$	1000 $\mu\text{S}/\text{cm}$	10 mS/cm	100 mS/cm	1000 mS/cm	2000 mS/cm
226	• • •		5 $\mu\text{S}/\text{cm}$ to 500 mS/cm				500 mS/cm to 2000 mS/cm	
225 & 228	• • • • • • • • • •			15 $\mu\text{S}/\text{cm}$ to 1500 mS/cm				1500 mS/cm to 2000 mS/cm
242	100 $\mu\text{S}/\text{cm}$ to 2000 mS/cm							
222 (1in & 2in)	500 $\mu\text{S}/\text{cm}$ to 2000 mS/cm							

#### Loop Performance (Following Calibration)

- Model 226:  $\pm 1\%$  of reading  $\pm 5 \mu\text{S}/\text{cm}$  in recommended range
- Models 225 & 228:  $\pm 1\%$  of reading  $\pm 10 \mu\text{S}/\text{cm}$  in recommended range
- Models 222, 242:  $\pm 4\%$  of reading in recommended range
- — — — — Model 225, 226 & 228:  $\pm 5\%$  of reading outside high recommended range
- • • • • Model 226:  $\pm 5 \mu\text{S}/\text{cm}$  outside low recommended range
- • • • • Models 225 & 228:  $\pm 15 \mu\text{S}/\text{cm}$  outside low recommended range

**Repeatability:**  $\pm 0.25\% \pm 5 \mu\text{S/cm}$  after zero cal  
**Input filter:** time constant 1 - 999 sec, default 2 sec.  
**Response time:** 3 seconds to 95% of final reading  
**Salinity:** Uses Practical Salinity Scale  
**Total Dissolved Solids:** Calculated by multiplying conductivity at 25°C by 0.65

## 2.5.2 Recommended Sensors for Conductivity

All Rosemount Analytical submersion/immersion and flow-through toroidal sensors.

## 2.6 Chlorine (Codes – CL)

### 2.6.1 Free and Total Chlorine

The 1066 is compatible with the 499ACL-01 free chlorine sensor and the 499ACL-02 total chlorine sensor. The 499ACL-02 sensor must be used with the TCL total chlorine sample conditioning system. The 1066 fully compensates free and total chlorine readings for changes in membrane permeability caused by temperature changes. For free chlorine measurements, both automatic and manual pH correction are available. For automatic pH correction select an appropriate pH sensor. For more information concerning the use and operation of the amperometric chlorine sensors and the TCL measurement system, refer to the product data sheets.

### 2.6.2 Performance Specifications

**Resolution:** 0.001 ppm or 0.01 ppm – selectable  
**Input Range:** 0nA – 100 $\mu$ A  
**Automatic pH correction for Free Chlorine:** (user selectable for code -CL): 6.0 to 10.0 pH  
**Temperature compensation:** Automatic (via RTD) or manual (0-50°C).  
**Input filter:** Time constant 1 - 999 sec, default 5 sec.  
**Response time:** 6 seconds to 95% of final reading



499ACL-01  
Chlorine sensor

### 2.6.3 Recommended Sensors

**Chlorine:** 499ACL-01 Free Chlorine or 499ACL-02 Total Residual Chlorine  
**pH:** These pH sensors are recommended for automatic pH correction of free chlorine readings: 3900-02-10, 3900-01-10, and 3900VP-02-10.

### 2.6.4 Monochloramine

The 1066 is compatible with the Model 499A CL-03 Monochloramine sensor. The 1066 fully compensates readings for changes in membrane permeability caused by temperature changes. Because monochloramine measurement is not affected by pH of the process, no pH sensor or correction is required. For more information concerning the use and operation of the amperometric chlorine sensors, refer to the product data sheets.

## 2.6.5 Performance Specifications

**Resolution:** 0.001 ppm or 0.01 ppm – selectable

**Input Range:** 0nA – 100µA

**Temperature compensation:** Automatic (via RTD) or manual (0-50°C).

**Input filter:** Time constant 1 - 999 sec, default 5 sec.

**Response time:** 6 seconds to 95% of final reading

## 2.6.6 Recommended Sensors

Rosemount Analytical 499ACL-03 Monochloramine sensor

## 2.7 Dissolved Oxygen (Codes –DO)

The 1066 is compatible with the 499ADO, 499ATrDO, Hx438, Gx438 and Bx438 dissolved oxygen sensors and the 4000 percent oxygen gas sensor. The 1066 displays dissolved oxygen in ppm, mg/L, ppb, µg/L, % saturation, % O<sub>2</sub> in gas, ppm O<sub>2</sub> in gas. The transmitter fully compensates oxygen readings for changes in membrane permeability caused by temperature changes. Automatic air calibration, including salinity correction, is standard. The only required user entry is barometric pressure. For more information on the use of amperometric oxygen sensors, refer to the product data sheets.

### 2.7.1 Performance Specifications

**Resolution:** 0.01 ppm; 0.1 ppb for 499A TrDO sensor (when O<sub>2</sub> < 1.00 ppm); 0.1%

**Input Range:** 0nA – 100µA

**Temperature Compensation:** Automatic (via RTD) or manual (0-50°C).

**Input filter:** Time constant 1 - 999 sec, default 5 sec.

**Response time:** 6 seconds to 95% of final reading



Dissolved Oxygen  
499ADO sensor with  
Variopol connection

### 2.7.2 Recommended Sensors

Rosemount Analytical amperometric membrane and steam-sterilizable sensors listed above

## 2.8 Dissolved Ozone (Codes –OZ)

The 1066 is compatible with the 499AOZ sensor. The 1066 fully compensates ozone readings for changes in membrane permeability caused by temperature changes. For more information concerning the use and operation of the amperometric ozone sensors, refer to the product data sheets.

### 2.8.1 Performance Specifications

**Resolution:** 0.001 ppm or 0.01 ppm – selectable

**Input Range:** 0nA – 100µA

**Temperature Compensation:** Automatic (via RTD) or manual (0-35°C)

**Input filter:** Time constant 1 - 999 sec, default 5 sec.

**Response time:** 6 seconds to 95% of final reading

NEED HIGH REZ  
SHOT



Dissolved Ozone  
499AOZ sensors with  
Variopol connection

### 2.8.2 Recommended Sensors

Rosemount Analytical 499A OZ ozone sensor

## 2.9 Ordering Information

The 1066 2-Wire Transmitter is intended for the continuous determination of pH, ORP (Redox), conductivity, (both contacting and toroidal), and for measurements using membrane-covered amperometric sensors (oxygen, ozone, free and total chlorine, and monochloramine). For free chlorine measurements, which often require continuous pH correction a second input for a pH sensor is available. Two 4-20mA analog outputs are standard on HART units. The 1066 is compatible with SMART pH sensors from Rosemount Analytical. HART digital communications is standard and FOUNDATION® fieldbus digital communications is offered as an option.

Communication with the 1066 is through:

- Local keypad interface
- 475 HART® and FOUNDATION fieldbus Communicator
- HART protocol version 7
- FOUNDATION fieldbus
- AMS (Asset Management Solutions) Aware
- SMART Wireless THUM™ Adapter

**TABLE 2-3. Ordering Information**

Description	
<b>1066 pH/ORP, Conductivity, Chlorine, Oxygen, and Ozone 2-Wire Transmitter</b>	
Measurement	
P	pH, ORP, Redox
C	Contacting Conductivity
T	Toroidal Conductivity
CL	Chlorine
DO	Dissolved Oxygen
OZ	Ozone
Communication	
HT	HART® Digital Communication Superimposed on 4-20mA Output
FF	FOUNDATION™ fieldbus Digital Output
FI	FOUNDATION™ fieldbus Digital Output with FISCO
Agency Approval	
60	None Required
67	FM Approved, Intrinsically Safe (appropriate sensor & safety barrier required), and Non-Incendive
69	CSA Approved , Intrinsically Safe (appropriate sensor & safety barrier required), and Non-Incendive
73	ATEX/IECEx Approved, Intrinsically Safe (safety barrier required)

**NOTE:** Ordering options shown in light gray text are pending.

## Section 3: Installation

### 3.1 Unpacking and inspection

Inspect the shipping container. If it is damaged, contact the shipper immediately for instructions. Save the box. If there is no apparent damage, unpack the container. Be sure all items shown on the packing list are present. If items are missing, notify Rosemount Analytical immediately.

### 3.2 Installation – general information

1. Although the transmitter is suitable for outdoor use, do not install in direct sunlight or in areas of extreme temperatures.
2. Install the transmitter in an area where vibration and electromagnetic and radio frequency interference are minimized or absent.
3. Keep the transmitter and sensor wiring at least one foot from high voltage conductors. Be sure there is easy access to the transmitter.
4. The transmitter is suitable for panel, pipe, or surface mounting.
5. The transmitter case has six 1/2-inch (PG13.5) conduit openings. Use separate conduit openings for the power/output cable, the sensor cable, and the other the sensor cable as needed (pH input for free chlorine with continuous pH correction).
6. Use weathertight cable glands to keep moisture out to the transmitter. If conduit is used, plug and seal the connections at the transmitter housing to prevent moisture from getting inside the instrument.

### 3.3 Preparing conduit openings

There are six conduit openings in all configurations of 1066.

Conduit openings accept 1/2-inch conduit fittings or PG13.5 cable glands. To keep the case watertight, block unused openings with NEMA 4X or IP66 conduit plugs.

To maintain ingress protection for outdoor use, seal unused conduit holes with suitable conduit plugs.

**NOTE:** Use watertight fittings and hubs that comply with your requirements. Connect the conduit hub to the conduit before attaching the fitting to the transmitter.

**Electrical installation must be in accordance with the National Electrical Code (ANSI/NFPA-70) and/or any other applicable national or local codes.**

FIGURE 3-1. Panel Mounting Dimensions

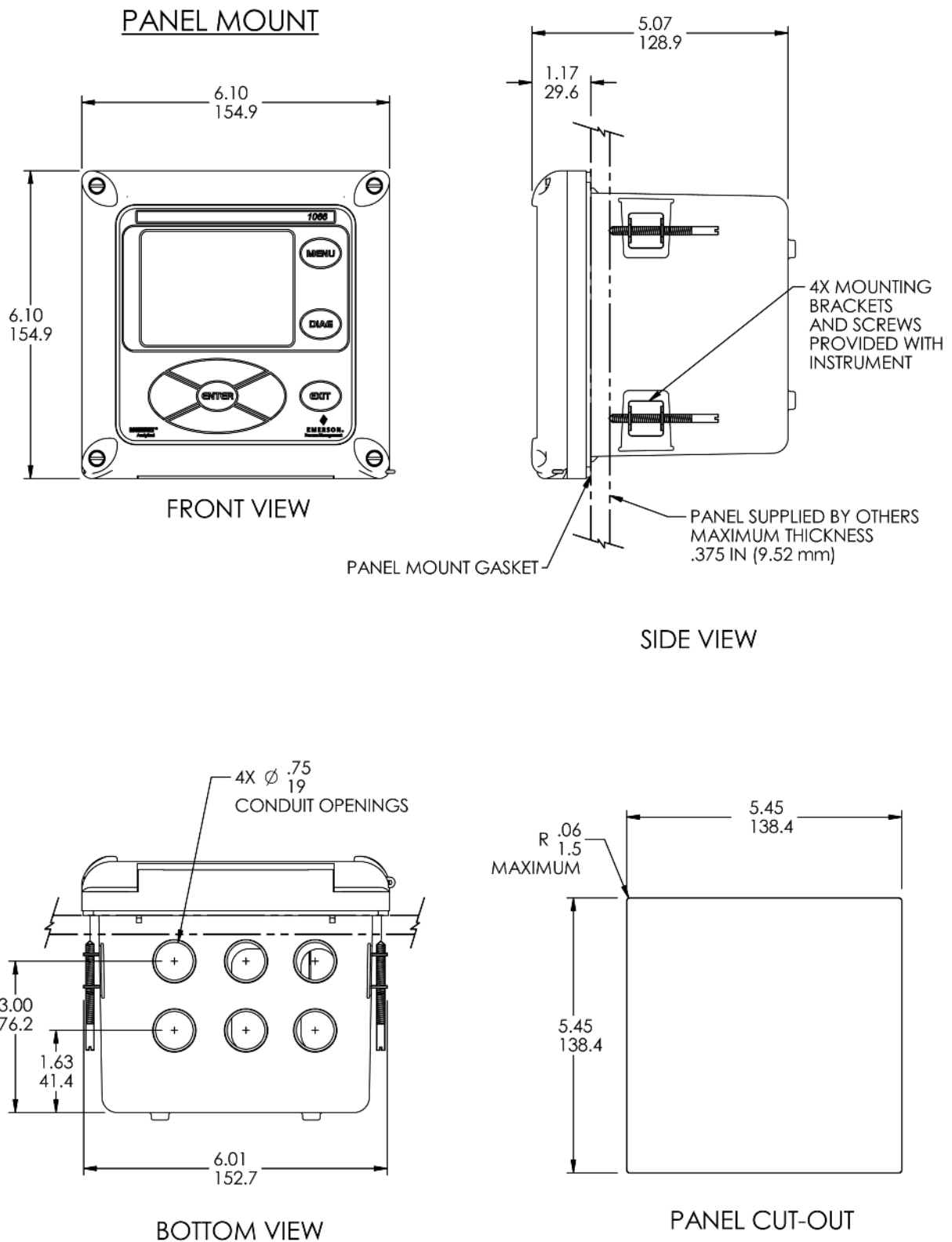
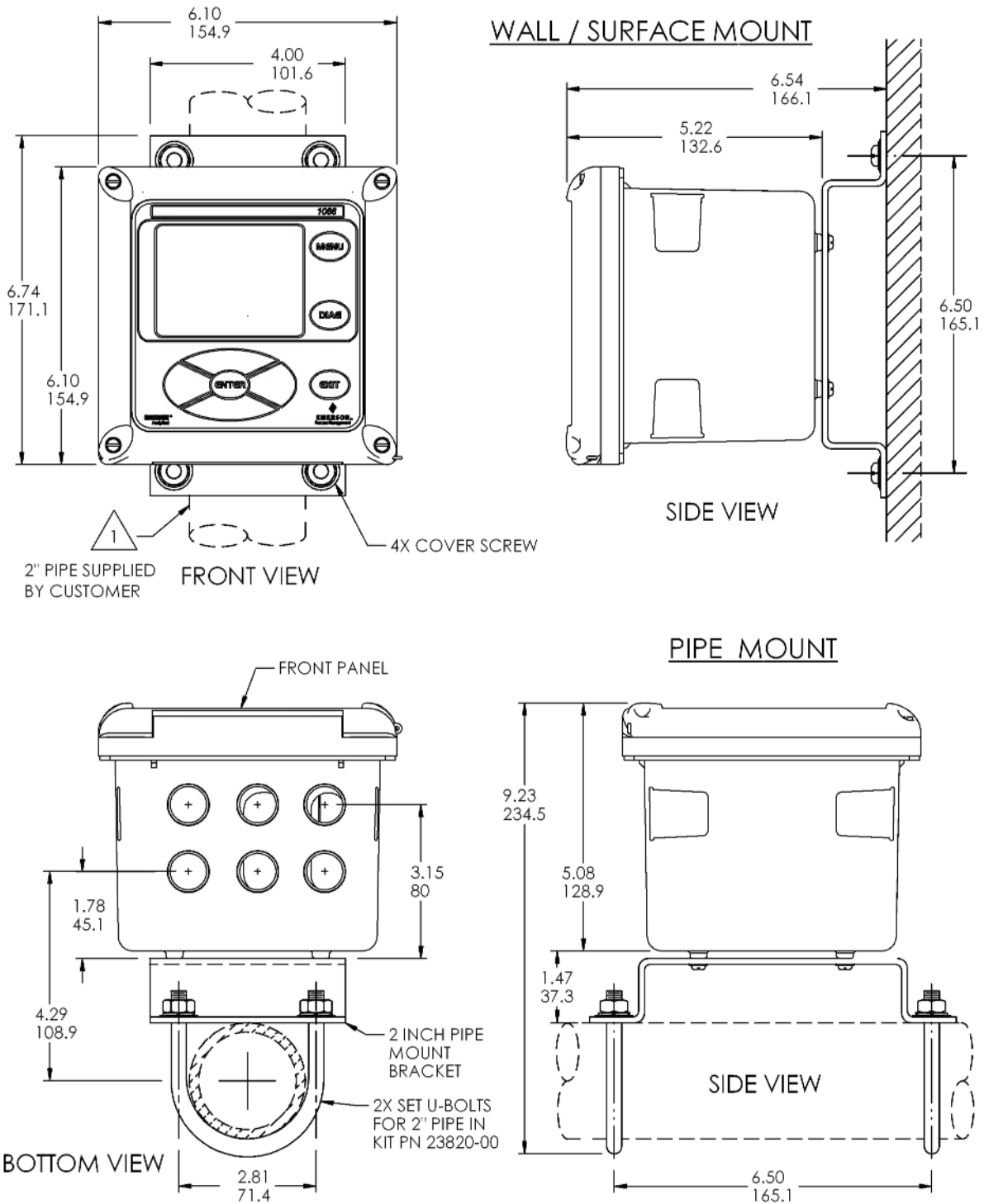

FIGURE 3-2. Pipe and wall mounting dimensions (Mounting bracket PN: 23820-00)



## Section 4: Wiring

### 4.1 General

#### 4.1.1 General Information

The 1066 is easy to wire. All wiring connections are located on the main circuit board. The front panel is hinged at the bottom. The panel swings down for easy access to the wiring locations.

#### 4.1.2 Digital Communication

HART and FOUNDATION fieldbus communications are available as ordering options for 1066. HART units support Bell 202 digital communications over analog 4-20mA current output 1.

### 4.2 Power Supply/Current Loop – 1066-HT

#### 4.2.1 Power Supply and Load Requirements

Refer to Figure 4-1. The supply voltage must be at least 12.7 Vdc at the transmitter terminals.. The power supply must be able to cover the voltage drop on the cable as well as the load resistor (250 Ω minimum) required for HART communications. The maximum power supply voltage is 42.0 Vdc. For intrinsically safe installations, the maximum power supply voltage is 30.0 Vdc. The graph shows load and power supply requirements. The upper line is the power supply voltage needed to provide 12.7 Vdc at the transmitter terminals for a 22 mA current. The lower line is the power supply voltage needed to provide 30 Vdc for a 22 mA current. The power supply must provide a surge current during the first 80 milliseconds of startup. The maximum current is about 24 mA.

For digital communications, the load must be at least 250 ohms. To supply the 12.7 Vdc lift off voltage at the transmitter, the power supply voltage must be at least 17.5 Vdc.

**FIGURE 4-1. Load/Power Supply Requirements**

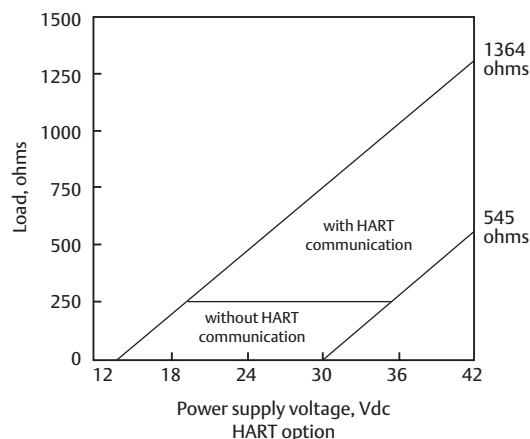

## 4.2.2 Power Supply-Current Loop Wiring

Refer to Figure 4-2.

Run the power/signal wiring through the opening nearest TB-2.

For optimum EMI/RFI protection:

1. Use shielded power/signal cable and ground the shield at the power supply.
2. Use a metal cable gland and be sure the shield makes good electrical contact with the gland.
3. Use the metal backing plate when attaching the gland to transmitter enclosure. The power/signal cable can also be enclosed in an earth-grounded metal conduit.

Do not run power supply/signal wiring in the same conduit or cable tray with loop power lines. Keep power supply/signal wiring at least 6 ft (2 m) away from heavy electrical equipment.

**FIGURE 4-2. HART Communications**

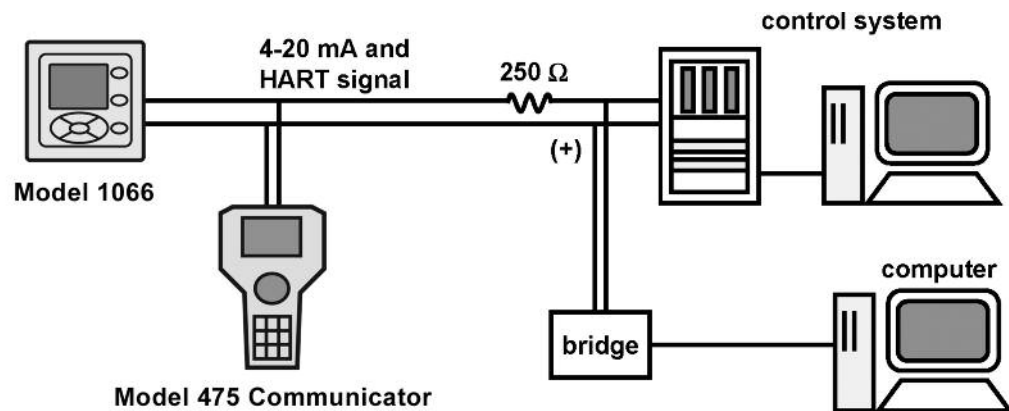

## 4.2.3 Current Output wiring

The 1066 HART units are shipped with two 4-20mA current outputs. Current Output 1 is loop power; it is the HART communications channel. Current output 2 is available to report process temperature measured by the temperature sensing element or RTD within the sensor.

Wiring locations for the outputs are on the main board which is mounted on the hinged door of the instrument. Wire the output leads to the correct position on the main board using the lead markings (+/positive, -/negative) on the board.

**FIGURE 4-3. 1066 HART Loop Power Wiring**

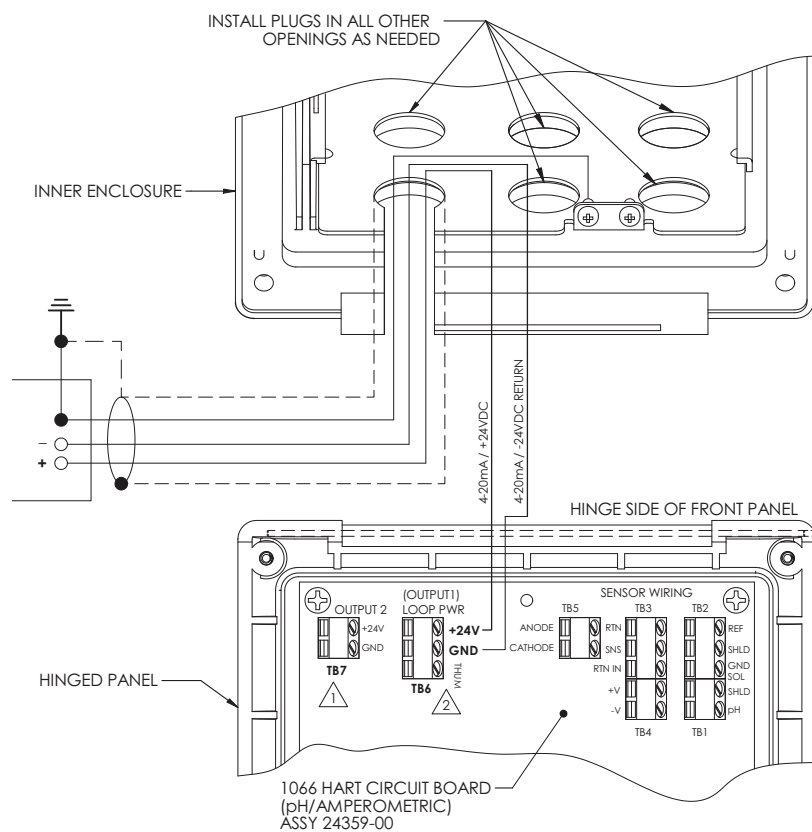

TB7/OUTPUT 2 REQUIRES EXTERNAL DC POWER.

TB6/THUM TERMINAL IS USED ONLY FOR WIRELESS THUM ADAPTOR INSTALLATIONS.

## 4.3 Power Supply Wiring For 1066-FF

### 4.3.1 Power Supply Wiring. Refer to Figure 4-3.

Run the power/signal wiring through the opening nearest TB2. Use shielded cable and ground the shield at the power supply. To ground the transmitter, attach the shield to TB2-3.

**NOTE:** For optimum EMI/RFI immunity, the power supply/output cable should be shielded and enclosed in an earth-grounded metal conduit. Do not run power supply/signal wiring in the same conduit or cable tray with loop power lines. Keep power supply/signal wiring at least 6 ft (2 m) away from heavy electrical equipment.

**FOUNDATION fieldbus**

Figure 4-4 shows a 1066-P-FF being used to measure and control pH and chlorine levels in drinking water. The figure also shows three ways in which Fieldbus communication can be used to read process variables and configure the transmitter.

**FIGURE 4-4. Configuring 1066-P Transmitter with FOUNDATION fieldbus**

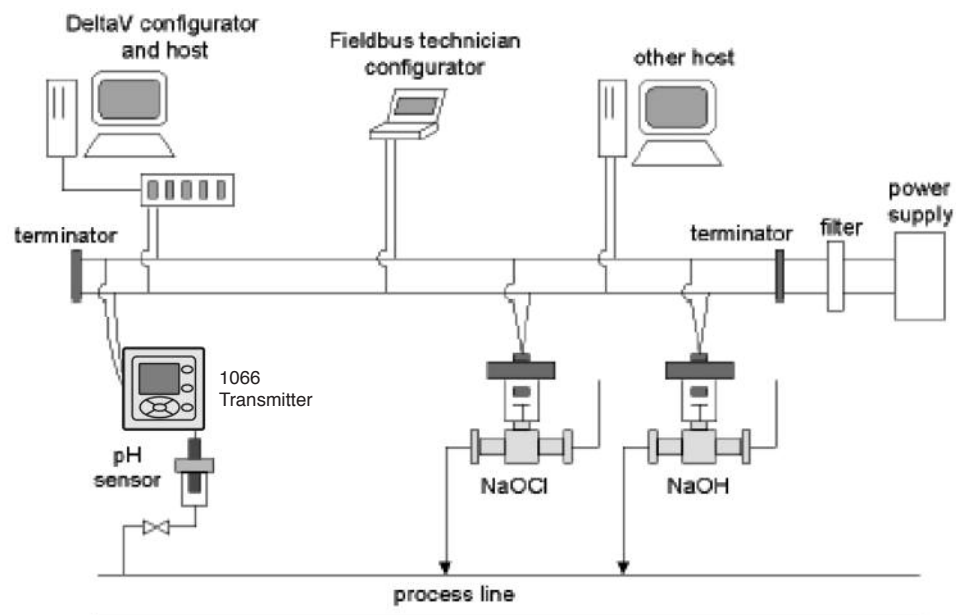

**FIGURE 4-5. Typical Fieldbus Network Electrical Wiring Configuration**

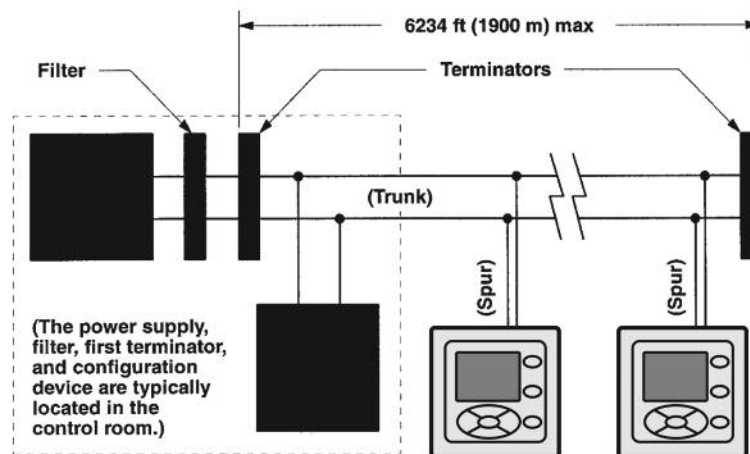

## 4.4 Sensor Wiring to Main Board

Wire the correct sensor leads to the main board using the lead locations marked directly on the board. Rosemount Analytical SMART pH sensors can be wired to the 1066 using integral cable SMART sensors or compatible VP8 pH cables. After wiring the sensor leads, carefully take up the excess sensor cable through the cable gland.

Keep sensor and output signal wiring separate from loop power wiring. Do not run sensor and power wiring in the same conduit or close together in a cable tray.

FIGURE 4-6. pH/ORP sensor wiring to the 1066 printed circuit board

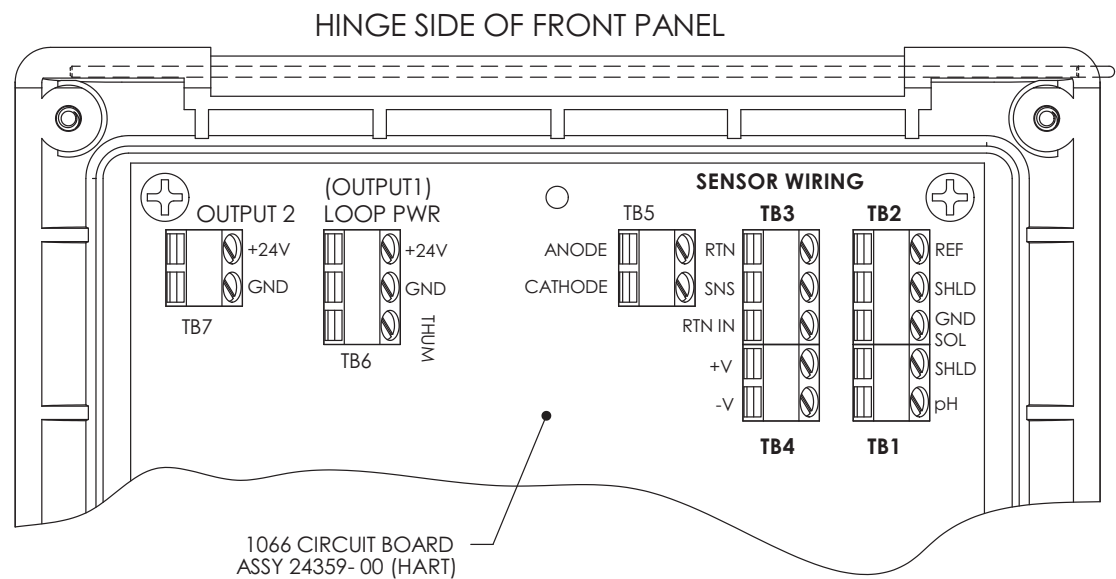

### pH/ORP SENSOR WIRING (FOLLOW RECOMMENDED ORDER)

- 1) **TB3/RTD**

RETURN
SENSE
RTD IN
  
- 2) **TB2/REFERENCE & SOLUTION GND**

REFERENCE IN
REFERENCE SHIELD
SOLUTION GROUND
  
- 3) **TB4/PREAMP (IF PRESENT)**



+VOLTS
-VOLTS
  
- 4) **TB1/pH INPUT**

pH SHIELD
pH IN

NOTE:

- A) IF GROUND LEAD IS PRESENT, TERMINATE IT TO GREEN GROUND SCREW ON INNER ENCLOSURE.
- B) TB5, TB6 AND TB7 NOT USED FOR pH/ORP SENSOR WIRING.

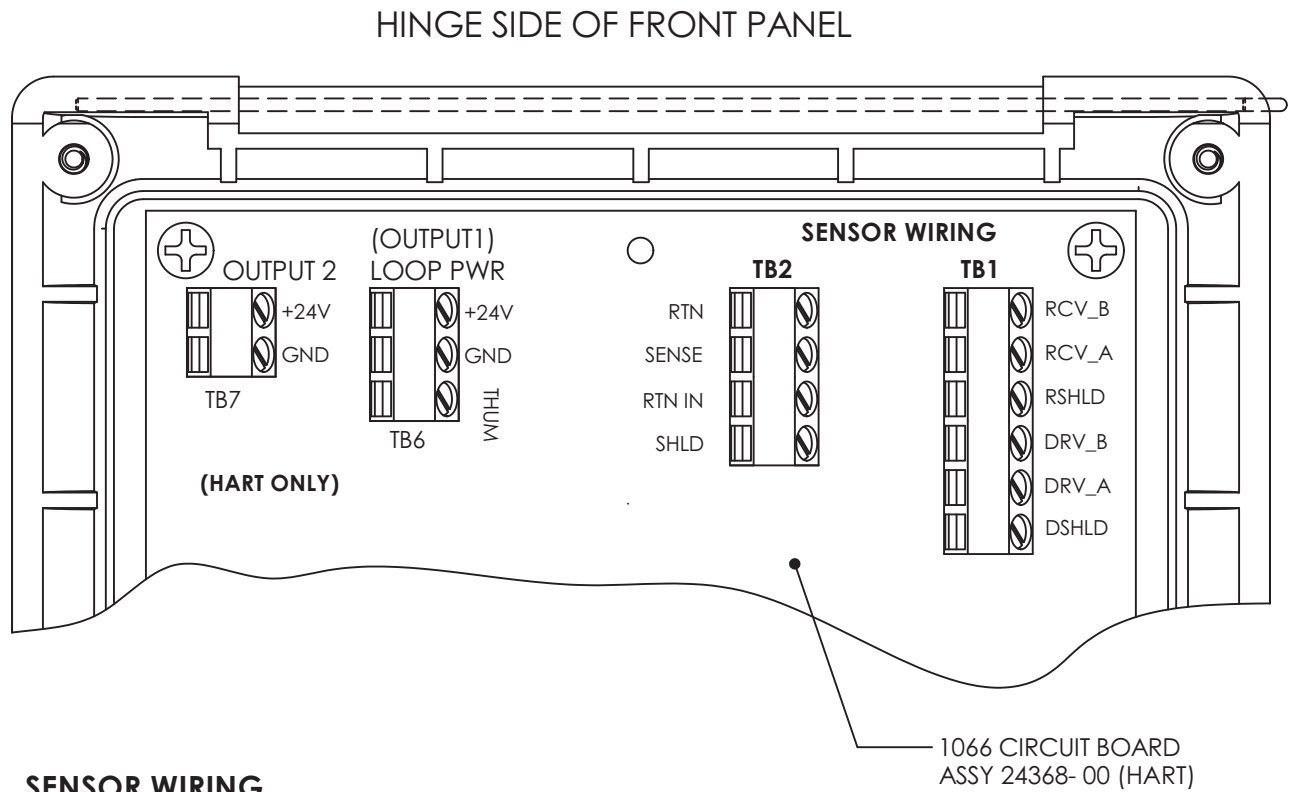
FIGURE 4-7. Contacting and Toroidal Conductivity sensor wiring to the 1066 circuit board



**SENSOR WIRING**  
(FOLLOW RECOMMENDED ORDER)

1) **TB2/RTD**

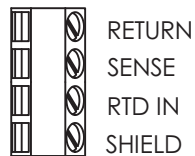

2) **TB1/CONDUCTIVITY**

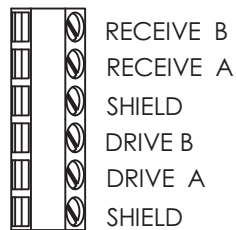
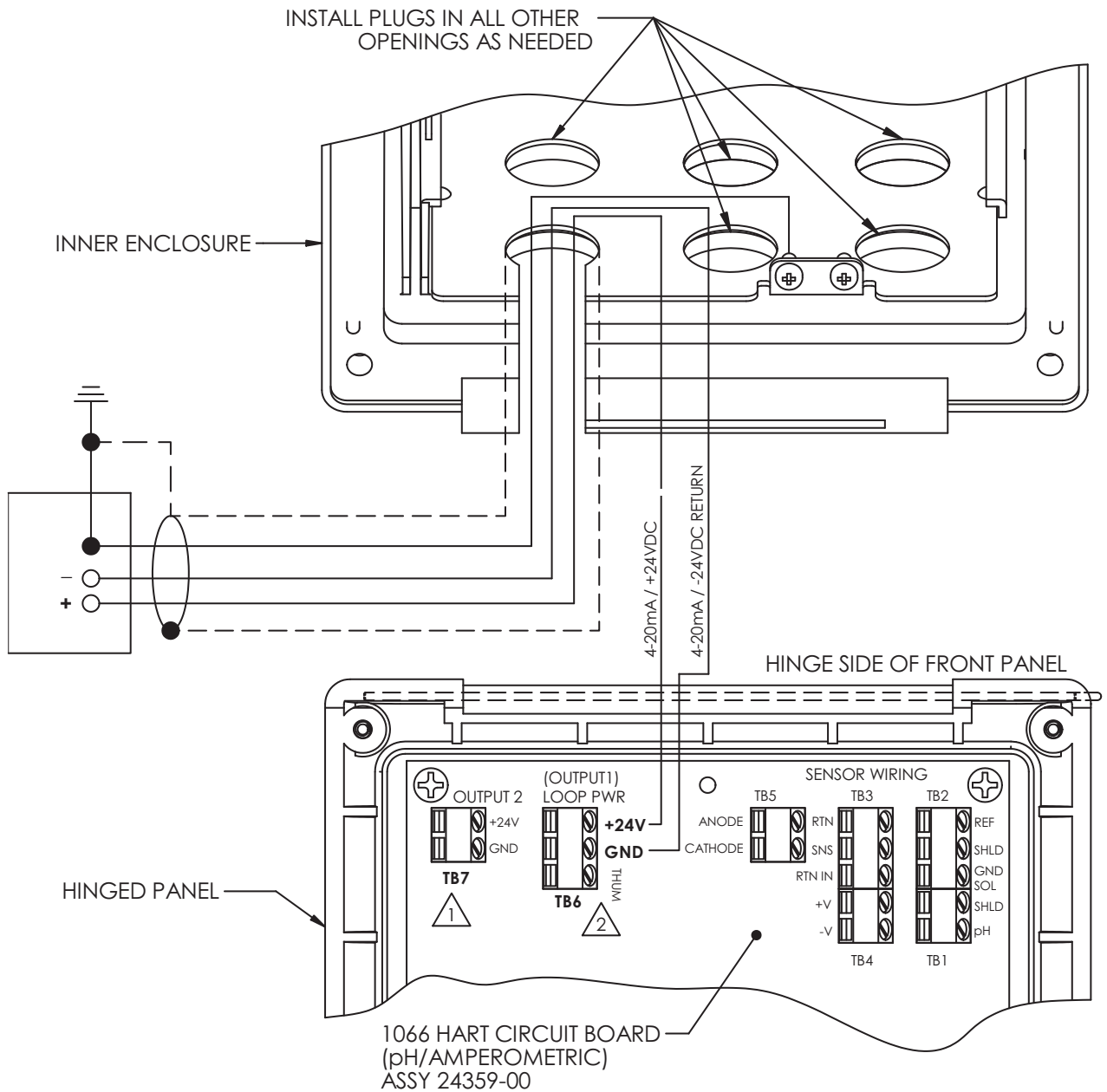



FIGURE 4-9. HART Loop Power Wiring



- 1 TB7/OUTPUT 2 REQUIRES EXTERNAL DC POWER.
- 2 TB6/THUM TERMINAL IS USED ONLY FOR WIRELESS THUM ADAPTOR INSTALLATIONS.

NOTES: UNLESS OTHERWISE SPECIFIED

# Section 5: Intrinsically Safe Installation

## 5.1 All Intrinsically Safe Installations

FIGURE 5-1. CSA Installation

The document contains information proprietary to  
Rockwell Automation and is not to be distributed  
outside your organization.

**APPROVED MODELS**  
**1066-PCLODOZ**

WHERE "AA" = MEASUREMENT TYPE EXAMPLES:

- CL = AMPEROMETRIC CHLORINE
- DO = AMPEROMETRIC DISSOLVED OXYGEN
- C = CONTACTING CONDUCTIVITY

WHERE "BB" = ANALOG/DIGITAL OUTPUT TYPE EXAMPLE:

- AN = 4-20 mA ANALOG CURRENT LOOP OUTPUT
- DI = DIGITAL OUTPUT
- FF = FOUNDATION FIELDBUS DIGITAL COMMUNICATION OPTION
- FF = FOUNDATION FIELDBUS INTRINSICALLY SAFE CONCEPT DIGITAL COMMUNICATION OPTION

WHERE "BB" SIGNIFIES THE INSTRUMENT WILL BE MARKED WITH THE CSA LOGO FOR INTRINSICALLY SAFE APPROVAL.

TABLE IA (FOR 1066-PCLODOZ)

GAS GROUPS	Ca (uF)	La (mH)
A, B	1.5	0.280
C	9.9	1.1
D	39	2.2

TABLE IA AND IIA ARE FOR CHLORINE, DO, OXYGEN AND OZONE OPTIONS

TABLE IIA (FOR 1066-PCLODOZ)

OUTPUT PARAMETERS	MODEL 1066 TBP-1 THRU 12
Uo	11.76 V
Io	358 mA
Po	420 mW

TABLE IB (FOR 1066-C)

GAS GROUPS	Ca (uF)	La (mH)
A, B	1.5	0.28
C	9.9	1.1
D	42	2.2

TABLES IB AND IIB ARE FOR CONTACTING CONDUCTIVITY

TABLE IIB (FOR 1066-C)

OUTPUT PARAMETERS	MODEL 1066 TBP-1 THRU 12
Uo	5.89 V
Io	505 mA
Po	214 mW

TABLE III

1066 SUPPLY ENTITY PARAMETERS	ENTITY PARAMETERS			
	Vmax (VDC)	Imax (mA)	Pmax (W)	Ci (uF)
MODEL NO.				
1066-AA-HT/AN-89 LOOP POWER SIGNAL TERMINALS TBP-1, -2 & -3	30	200	0.9	0
1066-AA-HT/AN-89 ANALOG OUTPUT 2 SIGNAL TERMINALS TBP-1 & -2	30	200	0.9	0
1066-AA-FF-69 LOOP POWER SIGNAL TERMINALS TBP-1 & -2	30	300	1.3	0
1066-AA-FF-69 LOOP POWER SIGNAL TERMINALS TBP-1 & -2	17.5	380	5.32	0
ENTITY PARAMETERS REMOTE TRANSMITTER INTERFACE				
MODEL NO.	Vmax (IN Vdc)	Imax (IN mA)	Pmax (IN W)	Ci (uF)
375 OR 475	30	200	1.0	0.0
Voc max OUT Vdc				
Isc max OUT I/A				
32				

(475 INSTALLATION DRAWING IS 00475-1139)

14. 1066 MODELS WITH P/CU/DO/OZ OPTIONS INCLUDE INTEGRAL PREAMPLIFIER CIRCUITRY. AN EXTERNAL PREAMPLIFIER MAY ALSO BE USED. THE OUTPUT PARAMETERS SPECIFIED IN TABLE I ARE VALID FOR EITHER PREAMPLIFIER. PREAMPLIFIERS MEETING THESE OUTPUT PARAMETERS INCLUDE ROSEMOUNT 22546-01, 22558-00, 22611-00 AND 170070Z PREAMPLIFIER ASSEMBLIES. A WEATHER RESISTANT ENCLOSURE MUST HOUSE THE TYPE 22546-01 REMOTE PREAMPLIFIER. THE WEATHER RESISTANT ENCLOSURE MUST BE APPROVED FOR USE WITH THE SENSOR. THE WEATHER RESISTANT ENCLOSURE MUST BE APPROVED FOR USE WITH THE SENSOR AS DESCRIBED IN ANSI/ISA 12.4 AND THE NEC. ANSI/NFPA 70. THEY CANNOT GENERATE HAZARDOUS STORE MORE THAN 15 V, 100 PPA, 25 mW OR A PASSIVE COMPONENT THAT DOES NOT DISSIPATE MORE THAN 1.3W.
12. THE MODEL 1066T HAS SYSTEM APPROVAL FOR USE WITH MODELS 222, 223, 226, 228, 242 AND 245 TOROIDAL SENSORS. 1066 MODELS WITH P/CU/DO/OZ OPTIONS HAVE OUTPUT ENTITY PARAMETERS WHICH ALLOW THE USE OF VARIOUS SENSORS SO LONG AS THE CAPACITANCE AND INDUCTANCE OF THE SENSOR CONNECTIONS DO NOT EXCEED THE VALUES SPECIFIED IN TABLE I WHERE:
- CO = CAPACITANCE (uF)
- LI = INDUCTANCE (mH)
- ANY SINGLE SHUNT THERMISTOR SAFETY BARRIER, APPROVED BY CSA HAVING THE FOLLOWING OUTPUT PARAMETERS:  
Voc OR Vi ≤ 30 V FOR 1066-AA-HT/AN-FF-69  
Isc OR Ii ≤ 200 mA FOR 1066-AA-HT/AN-69, ≤ 300 mA FOR 1066-AA-FF-69
10. THE INTRINSICALLY SAFE ENTITY CONCEPT ALLOWS INTERCONNECTION OF INTRINSICALLY SAFE DEVICES WITH ASSOCIATED APPARATUS WHEN THE FOLLOWING IS TRUE:  
FIELD DEVICE INPUT:  
Vmax OR Ui ≤ 11 V OR Uo  
Ii FOR Ii  
Pmax OR Pi ≤ 0.5 W  
Ci + Cooble ≤ 10 uF  
Li + Ltooble ≤ 10 mH  
ASSOCIATED APPARATUS OUTPUT:  
Voc, Vi OR Uo ≤ 11 V OR Uo  
Ii FOR Ii  
Pmax OR Pi ≤ 0.5 W  
Ci + Cooble ≤ 10 uF  
Li + Ltooble ≤ 10 mH
9. INTRINSICALLY SAFE APPARATUS (MODEL 1066, SMART THIN WIRELESS ADAPTER, MODEL 375, 475) AND ASSOCIATED APPARATUS (SAFETY BARRIER) SHALL MEET THE FOLLOWING REQUIREMENTS: THE VOLTAGE (Vmax) AND CURRENT (Imax) OF THE INTRINSICALLY SAFE APPARATUS MUST BE EQUAL TO OR LESS THAN THE VOLTAGE (Voc) AND CURRENT (Isc) OF THE SAFETY BARRIER. THE CAPACITANCE (Ci) AND INDUCTANCE (Li) OF THE INTRINSICALLY SAFE APPARATUS INCLUDING INTERCONNECTING WIRING, MUST BE EQUAL OR LESS THAN THE CAPACITANCE (Co) AND INDUCTANCE (Lo) WHICH CAN BE SAFELY CONNECTED TO THE APPARATUS. (REF. TABLES I, II AND III).
8. ASSOCIATED APPARATUS MANUFACTURERS' INSTALLATION DRAWINGS MUST BE FOLLOWED WHEN INSTALLING THIS EQUIPMENT.
7. CONTROL EQUIPMENT CONNECTED TO THIS EQUIPMENT MUST USE CABLES WHICH ARE MORE THAN 250 Vrms OR 60 Hz.
6. INSTALLATION SHALL BE IN ACCORDANCE WITH THE CANADIAN ELECTRICAL CODE (CEC), THE NATIONAL ELECTRICAL SAFETY SYSTEMS FOR HAZARDOUS (CLASSIFIED) LOCATIONS, AND THE CANADIAN ELECTRICAL CODE, CSA (C22.1), PART I, APPENDIX F.
5. DUST-TIGHT CONDUIT SEAL, MUST BE USED WHEN INSTALLED IN CLASS II AND CLASS III ENVIRONMENTS.
4. METAL CONDUITS REQUIRED IN NON-INCENDIVE INSTALLATIONS BUT IS NOT REQUIRED IN INTRINSICALLY SAFE INSTALLATIONS. HOWEVER, IF CONDUIT IS USED IN INTRINSICALLY SAFE INSTALLATIONS, THE RESISTANCE BETWEEN INTRINSICALLY SAFE GROUND AND EARTH GROUNDING MUST BE LESS THAN 1.0 Ohm.
3. THE ASSOCIATED APPARATUS MUST BE CSA APPROVED.
2. NO REVISION TO DRAWING WITHOUT PRIOR CSA APPROVAL.

NOTES: UNLESS OTHERWISE SPECIFIED



FIGURE 5-3. CSA Installation

This document contains information proprietary to Rosemount Analytical. All rights reserved. No part of this document may be reproduced, stored in a retrieval system, or transmitted, in any form or by any means, electronic, mechanical, photocopying, recording, or by any information storage and retrieval system, without prior written permission from Rosemount Analytical.

**APPROVED MODELS**  
**1066-AA-BB-69-XMTB**

WHERE 'AA' = MEASUREMENT TYPE, EXAMPLES:  
 P = pH/ORP  
 C = CAPACITANCE  
 DO = DISSOLVED OXYGEN  
 OZ = OZONE  
 C = CONTACTING CONDUCTIVITY  
 T = TOROIDAL CONDUCTIVITY

WHERE 'BB' = ANALOG/DIGITAL OUTPUT TYPE, EXAMPLES:  
 AN = 4-20 mA ANALOG CURRENT LOOP OUTPUT  
 DI = DIGITAL INPUT

WHERE '69' = COMMUNICATION OPTION AND HART COMMUNICATION  
 FF = FOUNDATION FIELDBUS DIGITAL COMMUNICATION OPTION  
 FI = FISCO (FIELDBUS INTRINSICALLY SAFE CONCEPT) DIGITAL COMMUNICATION OPTION  
 WHERE '69' SIGNIFIES THAT THE INSTRUMENT WILL BE MARKED WITH THE CSA LOGO FOR INTRINSIC SAFETY APPROVAL.

WARNING- SUBSTITUTION OF COMPONENTS MAY IMPAIR INTRINSIC SAFETY OR SUITABILITY FOR DIVISION 2.  
 WARNING- TO PREVENT IGNITION OF FLAMMABLE OR COMBUSTIBLE ATMOSPHERES, DISCONNECT POWER BEFORE SERVICING.

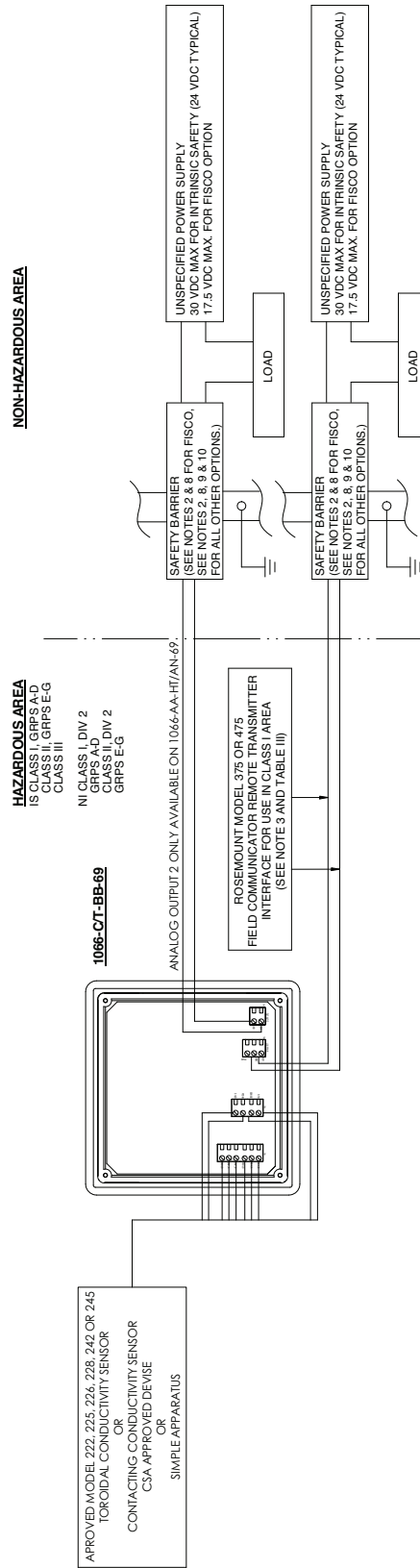
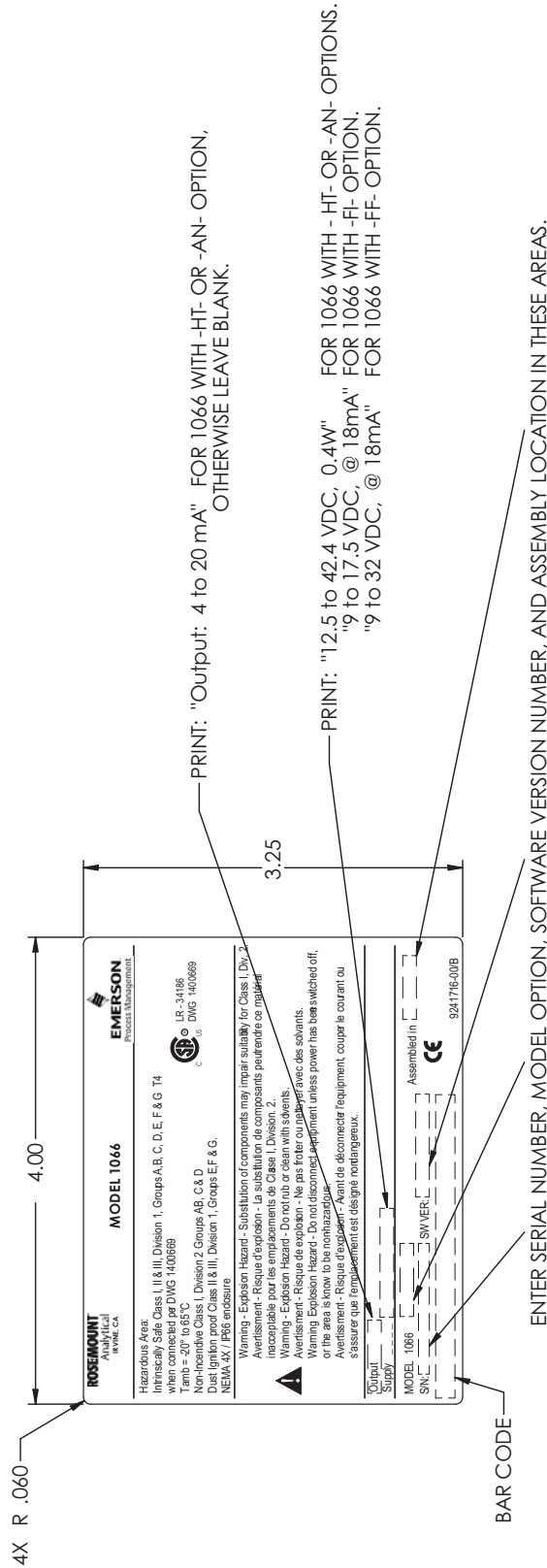

FIGURE 5-4. CSA Label Information

This document contains information proprietary to Rosemount Analytical, and is not to be made available to those who may compete with Rosemount Analytical.



2. NO CHANGE WITHOUT CSA APPROVAL.

1. MATERIAL: INTERMEC PN L7211210, 2 MIL GLOSS WHITE POLYESTER WITH PRESSURE SENSITIVE ACRYLIC ADHESIVE. NOMENCLATURE TO BE PRINTED USING INTERMEC SUPER PREMIUM BLACK THERMAL TRANSFER RIBBON. SEE BLANK LABEL PN 9241406-01.

NOTES: UNLESS OTHERWISE SPECIFIED

FIGURE 5-5. ATEX, IECEx Label Information

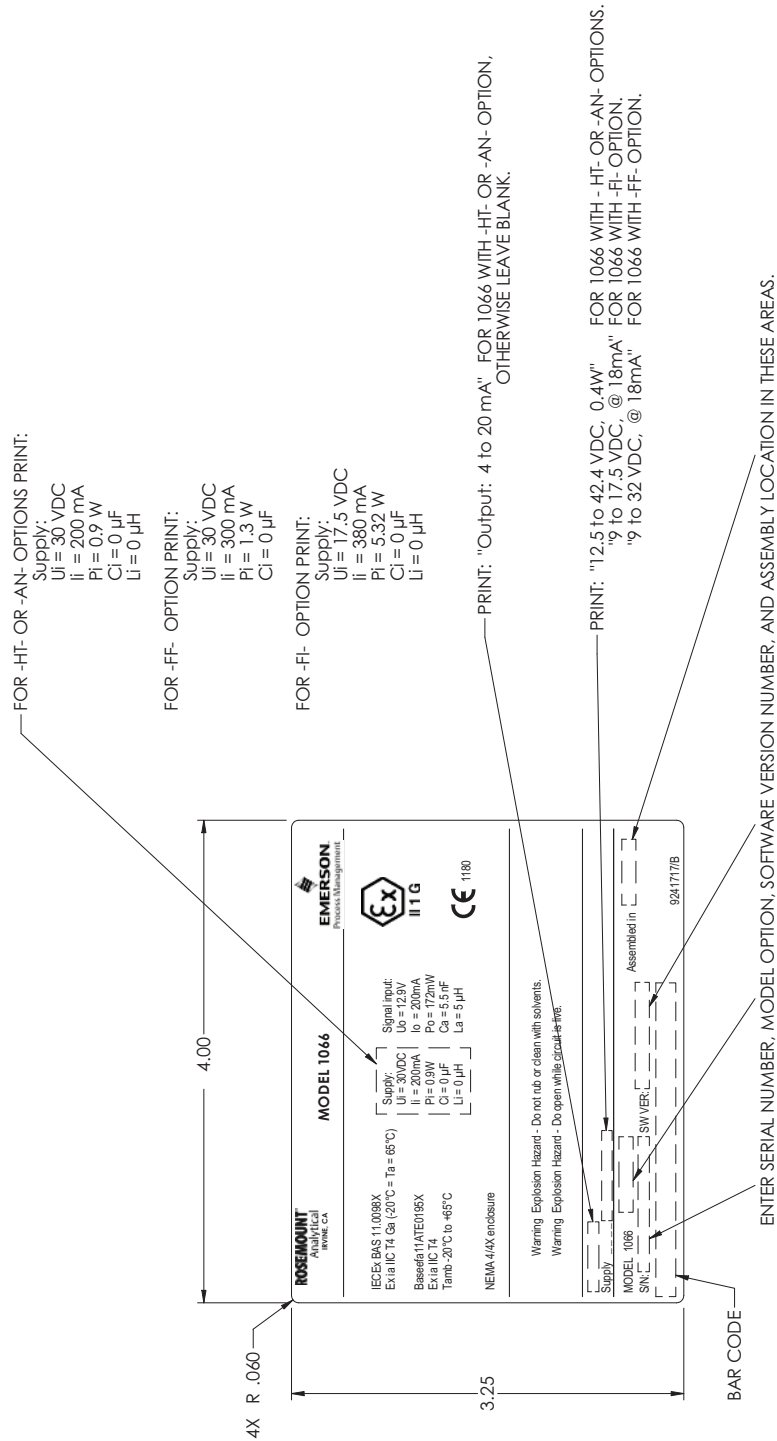

This document contains information proprietary to Rosemount Analytical, and is not to be made available to those who may compete with Rosemount Analytical.

- NO CHANGE WITHOUT BASEEFA APPROVAL.
- ⚠ MATERIAL: INTERMEC PN L7211210, 2 MIL GLOSS WHITE POLYESTER WITH PRESSURE SENSITIVE ACRYLIC ADHESIVE. NOMENCLATURE TO BE PRINTED USING INTERMEC SUPER PREMIUM BLACK THERMAL TRANSFER RIBBON. SEE BLANK LABEL PN 9241406-01.
- NOTES: UNLESS OTHERWISE SPECIFIED

## Section 6: Display and Operation

### 6.1 User Interface

The 1066 has a large display which shows the measurement readout and temperature in large digits and up to four additional process variables or diagnostic parameters concurrently. The displayed variables can be customized to meet user requirements. This is called display Format. The intuitive menu system allows access to Calibration, Hold (of current outputs), Programming, and Display functions. In addition, a dedicated DIAG button is available to provide access to useful operational information on installed sensor(s) and any problematic conditions that might occur. The display flashes Fault and/or Warning when these conditions occur. Help screens are displayed for most fault and warning conditions to guide the user in troubleshooting. During calibration and programming, key presses cause different displays to appear. The displays are self-explanatory and guide the user step-by-step through the procedure.



### 6.2 Instrument Keyboard

There are four Function keys and four Selection keys on the instrument keypad.

#### Function Keys:

The **MENU key** is used to access menus for programming and calibrating the instrument. Four top-level menu items appear when pressing the MENU key:

- Calibrate: calibrate the attached sensor and analog output(s).
- Hold: Suspend current output(s).
- Program: Program outputs, measurement, temperature, security and reset.
- Display: Program display format, language, warnings, and contrast

Pressing **MENU** from the main (live values) screen always causes the main menu screen to appear. Pressing MENU followed by EXIT causes the main screen to appear.

Pressing the **DIAG key** displays active Faults and Warnings, and provides detailed instrument information and sensor diagnostics including: Faults, Warnings, Sensor information, Out 1 and Out 2 live current values, model configuration string e.g. 1066-P-HT-60 and Instrument Software version. Pressing DIAG provides useful diagnostics and information (as applicable): Measurement, Sensor Type, Raw signal value, Cell constant, Zero Offset, Temperature, Temperature Offset, selected measurement range, Cable Resistance, Temperature Sensor Resistance, software version.

**The ENTER key.** Pressing ENTER stores numbers and settings and moves the display to the next screen.

**The EXIT key.** Pressing EXIT returns to the previous screen without storing changes.

### Selection Keys:

Surrounding the ENTER key, four Selection keys – up, down, right and left, move the cursor to all areas of the screen while using the menus.

Selection keys are used to:

1. Select items on the menu screens
2. Scroll up and down the menu lists
3. Enter or edit numeric values
4. Move the cursor to the right or left
5. Select measurement units during operations

## 6.3 Main Display

The 1066 displays the primary measurement value and temperature, and up to four secondary measurement values, a fault and warning banner, and a digital communications icon.

### Process Measurements:

One process variable and process temperature is displayed by default. For all configurations, the Upper display area shows the live process variable and the Center display area shows the Temperature (default screen settings).

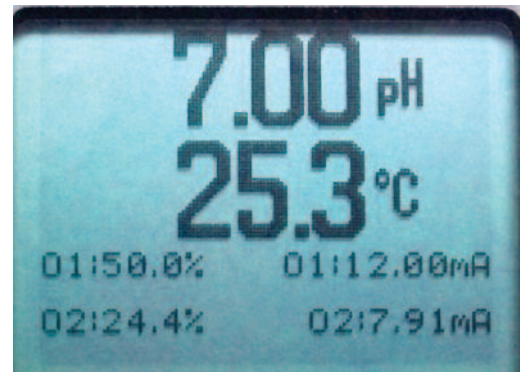

### Secondary Values:

Up to four secondary values are shown in display quadrants at the bottom half of the screen. All four secondary value positions can be programmed by the user to any displayable parameter available.

### Fault and Warning Banner:

If the transmitter detects a problem with itself or the sensor the word Fault or Warning will appear at the bottom of the display. A fault requires immediate attention. A warning indicates a problematic condition or an impending failure. For troubleshooting assistance, press Diag.

### Formatting the Main Display

The main display screen can be programmed to show primary process variables, secondary process variables and diagnostics.

1. Press MENU
2. Scroll down to **Display**. Press **ENTER**.
3. **Main Format** will be highlighted. Press **ENTER**.
4. The sensor 1 process value will be highlighted in reverse video. Press the selection keys to navigate down to the screen sections that you wish to program. Press **ENTER**.
5. Choose the desired display parameter or diagnostic for each of the four display sections in the lower screen.
6. Continue to navigate and program all desired screen sections. Press **MENU** and **EXIT**. The screen will return to the main display.

The default display shows the live process measurement in the upper display area and temperature in the center display area. The user can elect to disable the display of temperature in the center display area using the Main Format function. See Fig. 4-1 to guide you through programming the main display to select process parameters and diagnostics of your choice.

## 6.4 Menu System

The 1066 uses a scroll and select menu system. Pressing the MENU key at any time opens the top-level menu including Calibrate, Hold, Program and Display functions.

To find a menu item, scroll with the up and down keys until the item is highlighted. Continue to scroll and select menu items until the desired function is chosen.

To select the item, press ENTER. To return to a previous menu level or to enable the main live display, press the EXIT key repeatedly. To return immediately to the main display from any menu level, simply press MENU then EXIT.

The selection keys have the following functions:

- The Up key (above ENTER) increments numerical values, moves the decimal place one place to the right, or selects units of measurement.
- The Down key (below ENTER) decrements numerical values, moves the decimal place one place to the left, or selects units of measurement
- The Left key (left of ENTER) moves the cursor to the left.
- The Right key (right of ENTER) moves the cursor to the right.

To access desired menu functions, use the Quick Reference. During all menu displays (except main display format and Quick Start), the live process measurement and temperature value are displayed in the top two lines of the Upper display area. This conveniently allows display of the live values during important calibration and programming operations. Menu screens will time out after two minutes and return to the main live display.

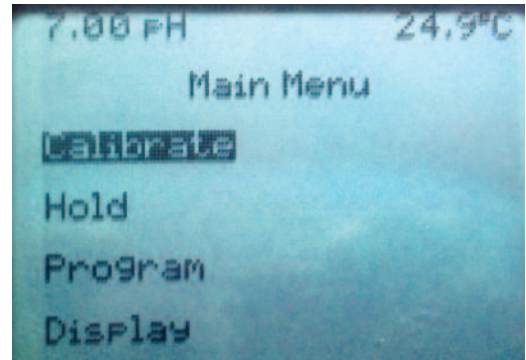

# Section 7: Programming the Transmitter – Basics

## 7.1 General

Typical programming steps include the following listed procedures. Each of these programming functions are easily and quickly accomplished using the intuitive menu system.

- Changing the measurement type, measurement units and temperature units.
- Choose temperature units and manual or automatic temperature compensation mode
- Configure and assign values to the current outputs
- Set a security code for two levels of security access
- Accessing menu functions using a security code
- Enabling and disabling Hold mode for current outputs
- Resetting all factory defaults, calibration data only, or current output settings only

## 7.2 Changing Startup Settings

### 7.2.1 Purpose

To change the measurement type, measurement units, or temperature units that were initially entered in Quick Start, choose the Reset analyzer function or access the Program menus for the sensor. The following choices for specific measurement type, measurement units are available for each sensor measurement board.

**TABLE 7-1. Measurements and Measurement Units**

Signal board	Available measurements	Measurements units:
pH/ORP – P	pH, ORP, Redox	pH, mV (ORP, Redox)
Contacting conductivity – C	Conductivity, Resistivity, TDS, Salinity, NaOH (0-12%), HCl (0-15%), Low H <sub>2</sub> SO <sub>4</sub> , High H <sub>2</sub> SO <sub>4</sub> , NaCl (0-20%), Custom Curve	μS/cm, mS/cm, S/cm % (concentration)
Toroidal conductivity –T	Conductivity, Resistivity, TDS, Salinity, NaOH (0-12%), HCl (0-15%), Low H <sub>2</sub> SO <sub>4</sub> , High H <sub>2</sub> SO <sub>4</sub> , NaCl (0-20%), Custom Curve	μS/cm, mS/cm, S/cm % (concentration)
Chlorine – CL	Free Chlorine, Total Chlorine, Monochloramine	ppm, mg/L
Oxygen – DO	Oxygen (ppm), Trace Oxygen (ppb), Percent Oxygen in gas	ppm, mg/L, ppb, μg/L % Sat, Partial Pressure, % Oxygen In Gas, ppm Oxygen In Gas
Ozone – OZ	Ozone	ppm, mg/L, ppb, μg/L

## 7.2.2 Procedure

Follow the Reset Analyzer procedure (Sec 7.8) to reconfigure the transmitter to display new measurements or measurement units. To change the specific measurement or measurement units for each measurement type, refer to the Program menu for the appropriate measurement (Sec. 6.0).

## 7.3 Choosing Temperature Units and Automatic/Manual Temperature Compensation

### 7.3.1 Purpose

Most liquid analytical measurements (except ORP and Redox) require temperature compensation. The 1066 performs temperature compensation automatically by applying internal temperature correction algorithms. Temperature correction can also be turned off. If temperature correction is off, the 1066 uses the temperature entered by the user in all temperature correction calculations.

### 7.3.2 Procedure

Most liquid analytical measurements (except ORP) require temperature compensation. The 1066 performs temperature compensation automatically by applying internal temperature correction algorithms. Temperature correction can also be turned off. If temperature correction is off, the 1066 uses the temperature entered by the user in all temperature correction calculations.

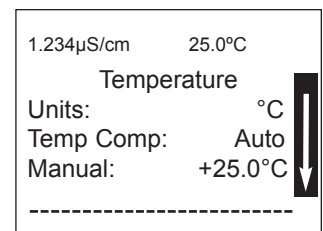

## 7.4 Configuring and Ranging Current Outputs

### 7.4.1 Purpose

The 1066 has two analog current outputs. Ranging the outputs means assigning values to the low (4 mA) and high (20 mA) outputs. This section provides a guide for configuring and ranging the outputs. ALWAYS CONFIGURE THE OUTPUTS FIRST.

## 7.4.2 Definitions

1. CURRENT OUTPUTS. The transmitter provides a continuous output current (4-20 mA) directly proportional to the process variable or temperature. The low and high current outputs can be set to any value.
2. ASSIGNING OUTPUTS. Assign a measurement or temperature to Output 1 or Output 2.
3. DAMPEN. Output dampening smooths out noisy readings. It also increases the response time of the output. Output dampening does not affect the response time of the display.
4. MODE. The current output can be made directly proportional to the displayed value (linear mode) or directly proportional to the common logarithm of the displayed value (log mode).

## 7.4.3 Procedure: Configure Outputs

Under the Program/Outputs menu, the adjacent screen will appear to allow configuration of the outputs. Follow the menu screens in Fig. 5-2 to configure the outputs.

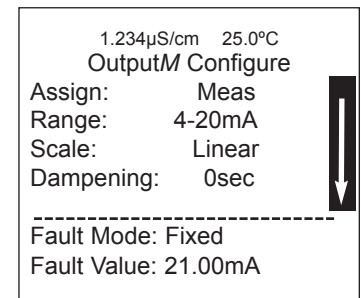

## 7.4.4 Procedure: Assigning Measurements the Low and High Current Outputs

The adjacent screen will appear when entering the Assign function under Program/Output/ Configure. These screens allow you to assign a measurement, process value, or temperature input to each output. Follow the menu screens in Fig. 7-1 to assign measurements to the outputs.

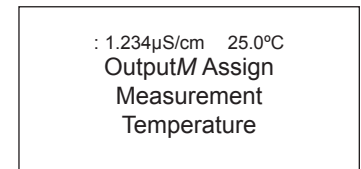

## 7.4.5 Procedure: Ranging the Current Outputs

The adjacent screen will appear under Program/Output/Range. Enter a value for 4mA and 20mA for each output. Follow the menu screens in Fig. 7-1 to assign values to the outputs.

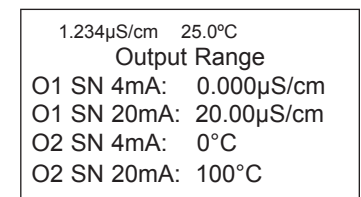

## 7.5 Setting a Security Code

### 7.5.1 Purpose

The security codes prevent accidental or unwanted changes to program settings, displays, and calibration. The 1066 has two levels of security code to control and use of the instrument to different types of users. The two levels of security are:

- **All:** This is the Supervisory security level. It allows access to all menu functions, including Programming, Calibration, Hold and Display.
- **Calibration/Hold:** This is the operator or technician level menu. It allows access to only calibration and Hold of the current outputs.

FIGURE 7-1. Configuring and Ranging the Current Outputs

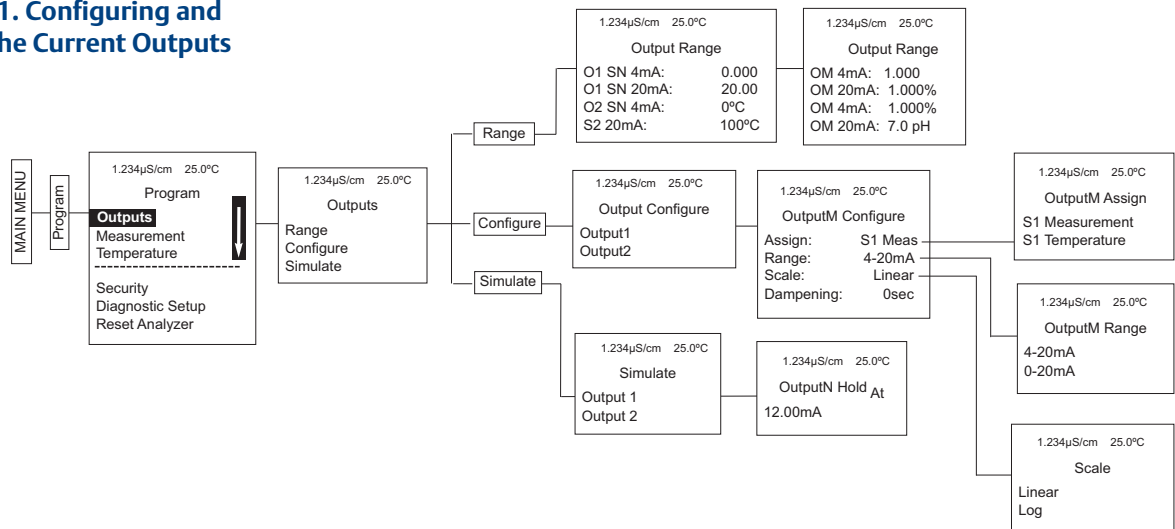

## 7.5.2 Procedure

1. Press MENU. The main menu screen appears. Choose **Program**.
2. Scroll down to Security. Select Security.
3. The security entry screen appears. Enter a three digit security code for each of the desired security levels. The security code takes effect two minutes after the last key stroke. Record the security code(s) for future access and communication to operators or technicians as needed.
4. The display returns to the security menu screen. Press EXIT to return to the previous screen. To return to the main display, press MENU followed by EXIT.

Fig. 7-2 displays the security code screens.

FIGURE 7-2. Setting a Security Code

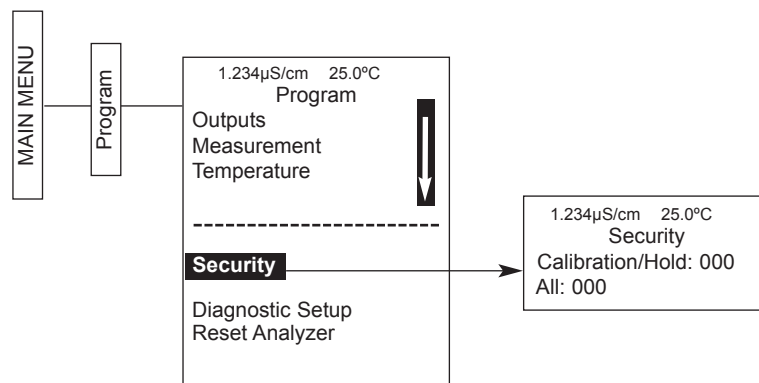

## 7.6 Security Access

### 7.6.1 How the Security Code Works

When entering the correct access code for the Calibration/Hold security level, the Calibration and Hold menus are accessible. This allows operators or technicians to perform routine maintenance. This security level does not allow access to the Program or Display menus. When entering the correct access code for All security level, the user has access to all menu functions, including Programming, Calibration, Hold and Display.

### 7.6.2 Procedure

1. If a security code has been programmed, selecting the Calibrate, Hold, Program or Display top menu items causes the security access screen to appear
2. Enter the three-digit security code for the appropriate security level.
3. If the entry is correct, the appropriate menu screen appears. If the entry is incorrect, the Invalid Code screen appears. The Enter Security Code screen reappears after 2 seconds.

1.234 $\mu$ S/cm 25.0°C
Security Code
000

## 7.7 Using Hold

### 7.7.1 Purpose

The transmitter output is always proportional to measured value. To prevent improper operation of systems or pumps that are controlled directly by the current output, place the analyzer in hold before removing the sensor for calibration and maintenance. Be sure to remove the transmitter from hold once calibration is complete. During hold, both outputs remain at the last value. Once in hold, all current outputs remain on Hold indefinitely.

### 7.7.2 Using the Hold Function

To hold the outputs,

1. Press MENU. The main menu screen appears. Choose **Hold**.
2. The **Hold Outputs?** screen appears. Choose Yes to place the analyzer in hold. Choose **No** to take the analyzer out of hold.
3. The Hold screen will then appear and **Hold will remain on indefinitely until Hold is disabled**. See figure 7-3.

FIGURE 7-3. Using Hold

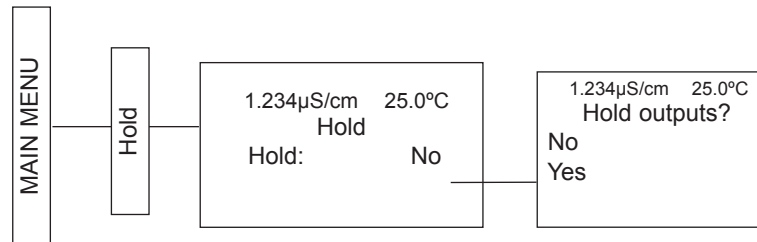

## 7.8 Resetting Factory Default Settings

### 7.8.1 Purpose

This section describes how to restore factory calibration and default values. The process also clears all fault messages and returns the display to the first Quick Start screen. The 1066 offers three options for resetting factory defaults.

- Reset all settings to factory defaults
- Reset sensor calibration data only
- Reset analog output settings only

### 7.8.2 Procedure

To reset to factory defaults, reset calibration data only or reset analog outputs only, follow the Reset Analyzer flow diagram.

FIGURE 7-4. Using Hold

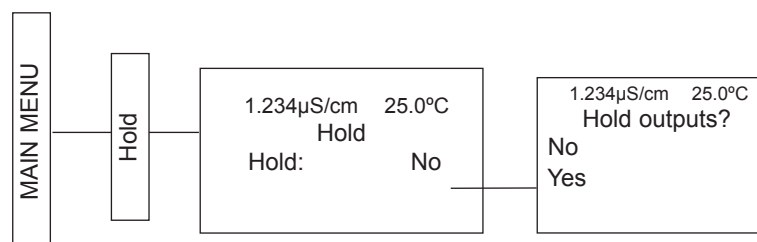

# Section 8: Programming Measurements

## 8.1 Introduction

The 1066 automatically recognizes the measurement input upon first power-up and each time the transmitter is powered. Completion of Quick Start screens upon first power up enable measurements, but additional steps may be required to program the transmitter for the desired measurement application. This section covers the following programming and configuration functions:

1. Selecting measurement type or sensor type (all sections)
2. Identifying the preamp location (pH-see Sec. 8.2)
3. Enabling manual temperature correction and entering a reference temperature (all sections)
4. Enabling sample temperature correction and entering temperature correction slope (selected sections)
5. Defining measurement display resolution (pH and amperometric)
6. Defining measurement display units (all sections)
7. Adjusting the input filter to control display and output reading variability or noise (all sections)
8. Selecting a measurement range (conductivity – see Sec's ??????)
9. Entering a cell constant for a contacting or toroidal sensor (see Sec's ??????)
10. Entering a temperature element/RTD offset or temperature slope (conductivity-see Sec's ???)
11. Creating an application-specific concentration curve (conductivity-see Sec's ??????)
12. Enabling automatic pH correction for free chlorine measurement (Sec. ??????)

To fully configure the transmitter, you may use the following:

1. Reset Transmitter function to reset factory defaults and configure to the desired measurement. Follow the Reset Transmitter menu to reconfigure the transmitter to display new measurements or measurement units.
2. Program menus to adjust any of the programmable configuration items. Use the following configuration and programming guidelines for the applicable measurement.

## 8.2 pH Measurement Programming

### 8.2.1 Description

The section describes how to configure the 1066 transmitter for pH measurements. The following programming and configuration functions are covered.

1. Measurement type: pH Select pH, ORP, Redox.
2. Preamp location: Transmitter Identify preamp location (automatic detection for SMART pH sensors)
3. Filter: 4 sec Override the default input filter, enter 0-999 seconds
4. Reference Z: Low Select low or high reference impedance
5. Resolution: 0.01pH Select 0.01pH or 0.1pH for pH display resolution

To configure pH:

1. Press **MENU**
2. Scroll down to **Program**. Press ENTER.
3. Scroll down to Measurement. Press ENTER.

The adjacent screen format will appear (factory defaults are shown).

To program any function, scroll to the desired item and press ENTER.

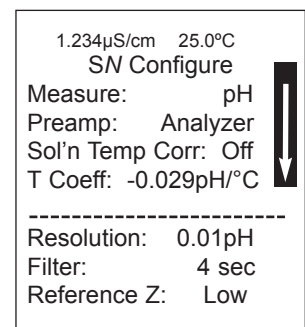

The following sub-sections provide you with the initial display screen that appears for each configuration function. Use the flow diagram for pH programming and the 1066 live screen prompts for each function to complete configuration and programming.

### 8.2.2 Measurement

The display screen for selecting the measurement is shown. The default value is displayed in bold type. Refer to the pH/ORP Programming flow diagram to complete this function.

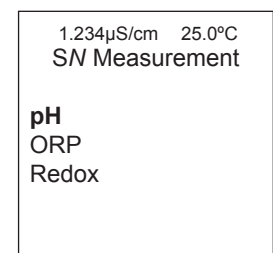

### 8.2.3 Preamp

The display screen for identifying the Preamp location is shown. The default value is displayed in bold type. Refer to the pH/ORP Programming flow diagram to complete this function.

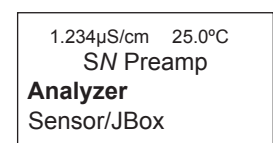

**Note:** Sensor/JBox must be selected to support SMART pH sensors from Rosemount Analytical.

## 8.2.4 Solution Temperature Correction

The display screen for selecting the Solution temperature correction algorithm is shown. The default value is displayed in **bold type**. Refer to the pH/ORP Programming flow diagram to complete this function.

1.234 $\mu$ S/cm 25.0°C  
SN Sol'n Temp Corr.  
**Off**  
Ultra Pure Water  
High pH  
Custom

## 8.2.5 Temperature Coefficient

The display screen for entering the custom solution temperature coefficient is shown. The default value is displayed in **bold type**. Refer to the pH/ORP Programming flow diagram to complete this function.

1.234 $\mu$ S/cm 25.0°C  
SN Sol'n Temp Coeff.  
- **0.032pH/°C**

## 8.2.6 Resolution

The display screen for selecting 0.01pH or 0.1pH for pH display resolution is shown. The default value is displayed in **bold type**. Refer to the pH/ORP Programming flow diagram to complete this function.

1.234 $\mu$ S/cm 25.0°C  
SN Resolution  
**0.01pH**  
0.1pH

## 8.2.7 Filter

The display screen for entering the input filter value in seconds is shown. The default value is displayed in **bold type**. Refer to the pH/ORP Programming flow diagram to complete this function.

1.234 $\mu$ S/cm 25.0°C  
SN Input filter  
**04 sec**

## 8.2.8 Reference Impedance

The display screen for selecting Low or High Reference impedance is shown. The default value is displayed in **bold type**. Refer to the pH/ORP Programming flow diagram to complete this function.

1.234 $\mu$ S/cm 25.0°C  
SN Reference Z  
**Low**  
High

## 8.3 ORP Measurement Programming

The section describes how to configure the 1066 transmitter for ORP measurements. The following programming and configuration functions are covered:

1. Measurement type: pH Select pH, ORP, Redox.
2. Preamp location: Transmitter Identify preamp location
3. Filter: 4 sec Override the default input filter, enter 0-999 seconds
4. Reference Z: Low Select low or high reference impedance
5. Sensor wiring scheme: Normal or Reference to Ground

To configure ORP:

1. Press **MENU**
2. Scroll down to **Program**. Press ENTER.
3. Scroll down to **Measurement**. Press ENTER.

1.234μS/cm	25.0°C
SN Configure	
Measure:	pH
Preamp:	Analyzer
Filter:	4 sec
Reference Z:	Low

The adjacent screen format will appear (factory defaults are shown).

To program any displayed function, scroll to the desired item and press ENTER.

The following sub-sections provide you with the initial display screen that appears for each configuration function. Use the **flow diagram for ORP programming** at the end of Sec. 6 and the 1066 live screen prompts for each function to complete configuration and programming.

### 8.3.1 Measurement

The display screen for selecting the measurement is shown. The default value is displayed in **bold type**. Refer to the pH/ORP Programming flow diagram to complete this function.

1.234μS/cm	25.0°C
SN Measurement	
pH	
<b>ORP</b>	
Redox	

### 8.3.2 Preamp

The display screen for identifying the Preamp location is shown. The default value is displayed in **bold type**. Refer to the pH/ORP Programming flow diagram to complete this function.

1.234μS/cm	25.0°C
SN Preamp	
<b>Analyzer</b>	
Sensor/JBox	

### 8.3.3 Filter

The display screen for entering the input filter value in seconds is shown. The default value is displayed in **bold type**. Refer to the pH/ORP Programming flow diagram to complete this function.

1.234μS/cm	25.0°C
SN Input filter	
<b>04 sec</b>	

### 8.3.4 Reference Impedance

The display screen for Selecting Low or high Reference impedance is shown. The default value is displayed in **bold type**. Refer to the pH/ORP Programming flow diagram to complete this function.

1.234μS/cm	25.0°C
SN Reference Z	
<b>Low</b>	
High	

## 8.4 Contacting Conductivity Measurement Programming

### 8.4.1 Description

The section describes how to configure the Model 1066 transmitter for conductivity measurements using contacting conductivity sensors. The following programming and configuration functions are covered.

1. Measure: Conductivity Select Conductivity, Resistivity, TDS, Salinity or % conc
2. Type: 2-Electrode Select 2-Electrode or 4-Electrode type sensors
3. Cell K: 1.00000/cm Enter the cell Constant for the sensor
4. Measurement units
5. Filter: 2 sec Override the default input filter, enter 0-999 seconds
6. Range: Auto Select measurement Auto-range or specific range
7. Temp Comp: Slope Select Temp Comp: Slope, Neutral Salt, Cation or Raw
8. Slope: 2.00%/°C Enter the linear temperature coefficient
9. Ref Temp: 25.0°C Enter the Reference temp
10. Cal Factor: default=0.95000/cm Enter the Cal Factor for 4-Electrode sensors from the sensor tag

To configure the contacting conductivity:

1. Press MENU
2. Scroll down to Program. Press ENTER.
3. Scroll down to Measurement. Press ENTER.

The adjacent screen format will appear (factory defaults are shown). To program any displayed function, scroll to the desired item and press ENTER.

1.234µS/cm	25.0°C
SN Configure	
Type:	2-Electrode
Measure:	Cond
Range:	Auto
Cell K:	1.00000/cm
RTD Offset:	0.00°C
RTD Slope:	0
Temp Comp:	Slope
Slope:	2.00%/°C
Ref Temp:	25.0°C
Filter:	2 sec
Custom Setup	

The following sub-sections provide you with the initial display screen that appears for each configuration function. Use the flow diagram for contacting conductivity programming at the end of Sec. 8 and the Model 1066 live screen prompts for each function to complete configuration and programming.

### 8.4.2 Sensor Type

The display screen for selecting 2-Electrode or 4-Electrode type sensors is shown. The default value is displayed in bold type. Refer to the contacting conductivity Programming flow diagram to complete this function.

1.234µS/cm	25.0°C
SN Type	
<b>2-Electrode</b>	
4-Electrode	

### 8.4.3 Measure

The display screen for selecting the measurement is shown. The default value is displayed in bold type. Refer to the contacting conductivity Programming flow diagram to complete this function.

1.234 $\mu$ S/cm 25.0°C  
SN Measurement  
**Conductivity**  
Resistivity  
TDS  
Salinity  
NaOH (0-12%)  
HCl (0-15%)  
Low H2SO4  
High H2SO4  
NaCl (0-20%)  
Custom Curve

### 8.4.4 Range

The display screen for Selecting Auto-ranging or a specific range is shown. The default value is displayed in bold type. Note: Ranges are shown as conductance, not conductivity. Refer to the contacting conductivity Programming flow diagram to complete this function.

1.234 $\mu$ S/cm 25.0°C  
SN Range  
**Auto**  
50  $\mu$ S  
500  $\mu$ S  
2000  $\mu$ S  
20 mS  
200 mS  
600 mS

### 8.4.5 Cell Constant

The display screen for entering a cell Constant for the sensor is shown. The default value is displayed in bold type. Refer to the contacting conductivity Programming flow diagram to complete this function.

1.234 $\mu$ S/cm 25.0°C  
SN Cell Constant  
**1.00000** /cm

### 8.4.6 RTD Offset

The display screen for Entering the RTD Offset for the sensor is shown. The default value is displayed in bold type. Refer to the contacting conductivity Programming flow diagram to complete this function.

1.234 $\mu$ S/cm 25.0°C  
SN RTD Offset  
**0.00**°C

### 8.4.7 RTD Slope

The display screen for entering the RTD slope for the sensor is shown. The default value is displayed in bold type. Refer to the contacting conductivity Programming flow diagram to complete this function.

1.234 $\mu$ S/cm 25.0°C  
SN RTD Slope  
**2.00**%/°C

### 8.4.8 Temp Comp

The display screen for Selecting Temperature Compensation as Slope, Neutral Salt, Cation or Raw is shown. The default value is displayed in bold type. Refer to the contacting conductivity Programming flow diagram to complete this function.

1.234 $\mu$ S/cm 25.0°C  
SN Temp Comp  
**Slope**  
Neutral Salt  
Cation  
Raw

### 8.4.9

#### Slope

The display screen for Entering the conductivity/temp Slope is shown. The default value is displayed in bold type. Refer to the contacting conductivity Programming flow diagram to complete this function.

```
1.234µS/cm  25.0°C
      SN Slope
2.00 %/°C
```

### 8.4.10

#### Reference Temp

The display screen for manually entering the Reference temperature is shown. The default value is displayed in bold type. Refer to the contacting conductivity Programming flow diagram to complete this function.

```
1.234µS/cm  25.0°C
      SN Ref Temp
      (25.0°C normal)
+25.0°C
```

### 8.4.11

#### Filter

The display screen for entering the input filter value in seconds is shown. The default value is displayed in bold type. Refer to the contacting conductivity Programming flow diagram to complete this function.

```
1.234µS/cm  25.0°C
      SN Input filter
02 sec
```

### 8.4.12

#### Custom Setup

The display screens for creating a custom curve for converting conductivity to concentration is shown. Refer to the contacting conductivity Programming flow diagram to complete this function.

```
1.234µS/cm  25.0°C
      SN Custom Curve
      Configure
      Enter Data Points
      Calculate Curve
```

When the custom curve data entry is complete, press ENTER. The display will confirm the determination of a custom curve fit to the entered data by displaying this screen:

```
1.234µS/cm  25.0°C
      SN Calculate Curve
      Custom curve
      fit completed.
      In Process Cal
      recommended.
```

If the custom curve fit is not completed or is unsuccessful, the display will read as follows and the screen will return to the beginning custom curve screen.

```
1.234µS/cm  25.0°C
      SN Calculate Curve
      Failure
```

### 8.4.13

#### Cal Factor

Upon initial installation and power up, if 4-electrode was selected for the sensor type in the Quick Start menus, the user enters a Cell Constant and a “Cal Factor” using the instrument keypad. The cell constant is needed to convert measured conductance to conductivity as displayed on the transmitter screen. The “Cal Factor” entry is needed increase the accuracy of the live conductivity readings, especially at low conductivity readings below 20uS/cm. Both the Cell Constant and the “Cal Factor” are printed on the tag attached to the 4-electrode sensor/cable.

```
1.234µS/cm  25.0°C
      SN Cal Factor
0.95000/cm
```

## 8.5 Toroidal Conductivity Measurement Programming

### 8.5.1 Description

The section describes how to configure the Model 1066 transmitter for conductivity measurements using inductive/toroidal sensors. The following programming and configuration functions are covered:

1. Measure: Conductivity Select Conductivity, Resistivity, TDS, Salinity or % conc
2. Sensor Model: 228 Select sensor type
3. Measurement units
4. Cell K: 3.00000/cm Enter the cell Constant for the sensors
5. Temp Comp: Slope Select Temp Comp: Slope, Neutral Salt, Cation or Raw
6. Slope: 2.00%/°C Enter the linear temperature coefficient
7. Ref Temp: 25.0°C Enter the Reference temp
8. Filter: 2 sec Override the default input filter, enter 0-999 seconds
9. Range: Auto Select measurement Auto-range or specific range

To configure toroidal conductivity:

1. Press MENU
2. Scroll down to Program. Press ENTER.
3. Scroll down to Measurement. Press ENTER.

The adjacent screen format will appear (factory defaults are shown). To program any displayed function, scroll to the desired item and press ENTER.

1.234μS/cm	25.0°C
SN Configure	
Model:	228
Measure:	Cond
Range:	Auto
Cell K: 3.00000/cm	
RTD Offset: 0.00°C	
RTD Slope: 0	
Temp Comp: Slope	
Slope: 2.00%/°C	
Ref Temp: 25.0°C	
Filter: 2 sec	
Custom Setup	

The following sub-sections provide you with the initial display screen that appears for each configuration function. Use the flow diagram for toroidal conductivity programming at the end of Sec. 8 and the 1066 live screen prompts for each function to complete configuration and programming.

### 8.5.2 Sensor Type

The display screen for selecting the sensor model is shown. The default value is displayed in bold type. Refer to the toroidal conductivity Programming flow diagram to complete this function.

1.234μS/cm	25.0°C
SN Model	
<b>228</b>	
225	
226	
247	
Other	

### 8.5.3 Measure

The display screen for selecting the measurement is shown. The default value is displayed in bold type. Refer to the toroidal conductivity Programming flow diagram to complete this function.

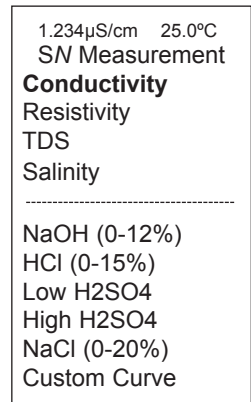

### 8.5.4 Range

The display screen for Selecting Auto-ranging or a specific range is shown. The default value is displayed in bold type. Note: Ranges are shown as conductance, not conductivity. Refer to the toroidal conductivity Programming flow diagram to complete this function.

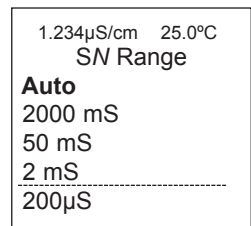

### 8.5.5 Cell Constant

The display screen for entering a cell Constant for the sensor is shown. The default value is displayed in bold type. Refer to the toroidal conductivity Programming flow diagram to complete this function.

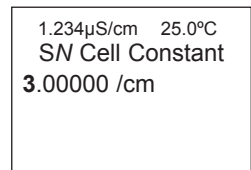

### 8.5.6 Temp Comp

The display screen for Selecting Temperature Compensation as Slope, Neutral Salt, or Raw is shown. The default value is displayed in bold type. Refer to the toroidal conductivity Programming flow diagram to complete this function.



### 8.5.7 Slope

The display screen for Entering the conductivity/temp Slope is shown. The default value is displayed in bold type. Refer to the toroidal conductivity Programming flow diagram to complete this function.

1.234 $\mu$ S/cm 25.0 $^{\circ}$ C  
SN Slope  
**2.00%/ $^{\circ}$ C**

### 8.5.8 Ref Temp

The display screen for manually Entering the Reference temperature is shown. The default value is displayed in bold type. Refer to the toroidal conductivity Programming flow diagram to complete this function.

1.234 $\mu$ S/cm 25.0 $^{\circ}$ C  
SN Ref Temp  
(25.0 $^{\circ}$ C normal)  
**+25.0 $^{\circ}$ C**

### 8.5.9 Filter

The display screen for entering the input filter value in seconds is shown. The default value is displayed in bold type. Refer to the toroidal conductivity Programming flow diagram to complete this function.

1.234 $\mu$ S/cm 25.0 $^{\circ}$ C  
SN Input filter  
**02 sec**

### 8.5.10 Custom Setup

The display screens for creating custom curves for converting conductivity to concentration is shown. Refer to the toroidal conductivity Programming flow diagram to complete this function.

1.234 $\mu$ S/cm 25.0 $^{\circ}$ C  
SN Custom Curve  
Configure  
Enter Data Points  
Calculate Curve

When the custom curve data entry is complete, press ENTER. The display will confirm the determination of a custom curve fit to the entered data by displaying this screen:

1.234 $\mu$ S/cm 25.0 $^{\circ}$ C  
SN Calculate Curve  
Custom curve  
fit completed.  
In Process Cal  
recommended.

If the custom curve fit is not completed or is unsuccessful, the display will read as follows and the screen will return to the beginning custom curve screen.

1.234 $\mu$ S/cm 25.0 $^{\circ}$ C  
SN Calculate Curve  
Failure

## 8.6 Chlorine Measurement Programming

The 1066 can measure any of three variants of Chlorine:

- Free Chlorine
- Total Chlorine
- Monochloramine

The section describes how to configure the Model 1066 transmitter for Chlorine measurements.

### 8.6.1 Free Chlorine Measurement Programming

This Chlorine sub-section describes how to configure the Model 1066 transmitter for Free Chlorine measurement using amperometric chlorine sensors. Automatic temperature compensation is available using Auto or Manual pH correction. For maximum accuracy, use automatic temperature compensation.

The following programming and configuration functions are covered:

1. Measure: Free Chlorine Select Free Chlorine, Total Cl, Monochloramine
2. Units: ppm Select units ppm or mg/L
3. Resolution: 0.001 Select display resolution 0.01 or 0.001
4. Free Cl Correct: Live Select Live/Continuous pH correction or Manual
5. Manual pH: 7.00 pH For Manual pH correction, enter the pH value
6. Filter: 5sec Override the default input filter, enter 0-999 seconds

To configure chlorine for free chlorine:

1. Press MENU
2. Scroll down to Program. Press ENTER.
3. Scroll down to Measurement. Press ENTER.

The adjacent screen format will appear (factory defaults are shown). To program any displayed function, scroll to the desired item and press ENTER.

1.234 $\mu$ S/cm	25.0°C
SN Configure	
Measure:	Free Chlorine
Units:	ppm
-----	
Filter:	5sec
Free Cl Correct:	Live
Manual pH:	7.00 pH
Resolution:	0.001

The following sub-sections provide you with the initial display screen that appears for each configuration function. Use the **flow diagram for chlorine programming** at the end of Sec. 8 and the Model 1066 live screen prompts for each function to complete configuration and programming.

### 8.6.1.1 Measure

The display screen for selecting the measurement is shown. The default value is displayed in bold type. Refer to the Chlorine Programming flow diagram to complete this function.

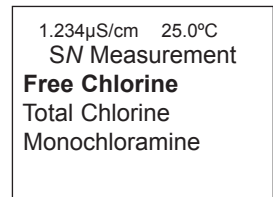

### 8.6.1.2 Units

The display screen for selecting units as ppm or mg/L is shown. The default value is displayed in bold type. Refer to the Chlorine Programming flow diagram to complete this function.

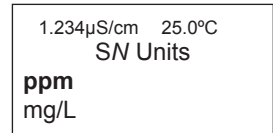

### 8.6.1.3 Filter

The display screen for entering the input filter value in seconds is shown. The default value is displayed in bold type. Refer to the Chlorine Programming flow diagram to complete this function.

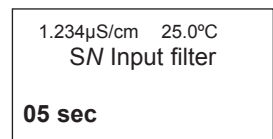

### 8.6.1.4 Free Chlorine pH Correction

The display screen for Selecting Live/Continuous pH correction or Manual pH correction is shown. The default value is displayed in bold type. Refer to the Chlorine Programming flow diagram to complete this function.

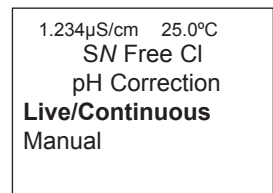

### 8.6.1.5 Manual pH Correction

The display screen for manually entering the pH value of the measured process liquid is shown. The default value is displayed in bold type. Refer to the Chlorine Programming flow diagram to complete this function.

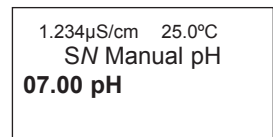

### 8.6.1.6 Resolution

The display screen for selecting display resolution as 0.001 or 0.01 is shown. The default value is displayed in bold type. Refer to the Chlorine Programming flow diagram to complete this function.

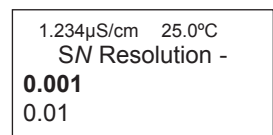

## 8.6.2 Total Chlorine Measurement Programming

### 8.6.2 Description

This Chlorine sub-section describes how to configure the 1066 transmitter for Total Chlorine measurement using amperometric chlorine sensors. The following programming and configuration functions are covered:

1. Measure: Free Chlorine Select Free Chlorine, pH Ind. Free Cl. Total Cl, Monochloramine
2. Units: ppm Select units ppm or mg/L
3. Resolution: 0.001 Select display resolution 0.01 or 0.001
4. Filter: 5sec Override the default input filter, enter 0-999 seconds

To configure chlorine measurement for total chlorine:

1. Press MENU
2. Scroll down to Program. Press ENTER.
3. Scroll down to Measurement. Press ENTER.

1.234 $\mu$ S/cm	25.0°C
SN Configure	
Measure: Free Chlorine	
Units:	ppm
Filter:	5sec
Resolution:	0.001

The adjacent screen format will appear (factory defaults are shown). To program any displayed function, scroll to the desired item and press ENTER.

The following sub-sections provide you with the initial display screen that appears for each configuration function. Use the flow diagram for chlorine programming at the end of Sec. 6 and the Model 1066 live screen prompts for each function to complete configuration and programming.

#### 8.6.2.2 Measure

The display screen for selecting the measurement is shown. The default value is displayed in bold type. Refer to the chlorine Programming flow diagram to complete this function.

1.234 $\mu$ S/cm	25.0°C
SN Measurement	
<b>Free Chlorine</b>	
Total Chlorine	
Monochloramine	

#### 8.6.2.3 Units

The display screen for selecting units as ppm or mg/L is shown. The default value is displayed in bold type. Refer to the Chlorine Programming flow diagram to complete this function

1.234 $\mu$ S/cm	25.0°C
SN Units	
<b>ppm</b>	
mg/L	

#### 8.6.2.4 Filter

The display screen for entering the input filter value in seconds is shown. The default value is displayed in bold type. Refer to the Chlorine Programming flow diagram to complete this function.

1.234 $\mu$ S/cm	25.0°C
SN Input filter	
<b>05 sec</b>	

### 8.6.2.5 Resolution

The display screen for selecting display resolution as 0.001 or 0.01 is shown. The default value is displayed in bold type. Refer to the Chlorine Programming flow diagram to complete this function.

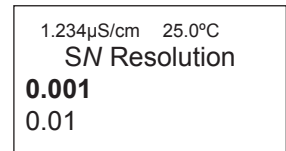

## 8.6.3 Monochloramine Measurement Programming

This Chlorine sub-section describes how to configure the 1066 transmitter for Monochloramine measurement using amperometric chlorine sensors. The following programming and configuration functions are covered:

1. Measure: Free Chlorine Select Free Chlorine, pH Ind. Free Cl. Total Cl, Monochloramine
2. Units: ppm Select units ppm or mg/L
3. Resolution: 0.001 Select display resolution 0.01 or 0.001
4. Filter: 5sec Override the default input filter, enter 0-999 seconds

To configure chlorine for monochloramine:

1. Press MENU
2. Scroll down to Program. Press ENTER.
3. Scroll down to Measurement. Press ENTER.

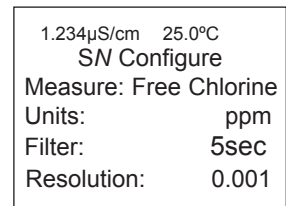

The following screen format will appear (factory defaults are shown). To program any displayed function, scroll to the desired item and press ENTER.

The following sub-sections provide you with the initial display screen that appears for each configuration function. Use the flow diagram for chlorine programming at the end of Sec. 8 and the 1066 live screen prompts for each function to complete configuration and programming.

### 8.6.3.1 Measure: Monochloramine

The display screen for selecting the measurement is shown. The default value is displayed in bold type. Refer to the Chlorine Programming flow diagram to complete this function.

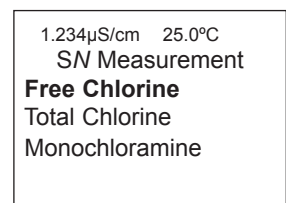

### 8.6.3.2 Units

The display screen for selecting units as ppm or mg/L is shown. The default value is displayed in bold type. Refer to the Chlorine Programming flow diagram to complete this function.

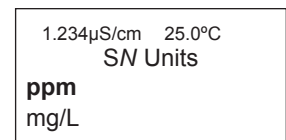

### 8.6.3.3 Filter

The display screen for entering the input filter value in seconds is shown. The default value is displayed in bold type. Refer to the Chlorine Programming flow diagram to complete this function.

1.234µS/cm	25.0°C
SN Input filter	
<b>05 sec</b>	

### 8.6.3.4 Resolution

The display screen for selecting display resolution as 0.001 or 0.01 is shown. The default value is displayed in bold type. Refer to the Chlorine Programming flow diagram to complete this function.

1.234µS/cm	25.0°C
SN Resolution	
<b>0.001</b>	
0.01	

## 8.7 Oxygen Measurement Programming

This section describes how to configure the Model 1066 transmitter for dissolved and gaseous oxygen measurement using amperometric oxygen sensors. The following programming and configuration functions are covered:

1. Sensor type: Select Water/Waste, Trace, BioRx, BioRx-Other, Brew, %O<sub>2</sub> In Gas
2. Measure type: Select Concentration, % Saturation, Partial Pressure, Oxygen in Gas
3. Units: ppm Select ppm, mg/L, ppb, g/L, % Sat, %O<sub>2</sub>-Gas, ppm Oxygen-Gas
4. Pressure Units: bar Select pressure units: mm Hg, in Hg, Atm, kPa, mbar, bar
5. Salinity: 00.0‰ Enter Salinity as ‰
6. Filter: 5sec Override the default input filter, enter 0-999 seconds
7. Partial Press: mmHg Select mm Hg, in Hg, atm, kPa, mbar or bar for Partial pressure

To configure Oxygen:

1. Press MENU
2. Scroll down to Program. Press ENTER.
3. Scroll down to Measurement. Press ENTER.

The adjacent screen format will appear (factory defaults are shown). To program any displayed function, scroll to the desired item and press ENTER.

1.234µS/cm	25.0°C
SN Configure	
Type:	Water/Waste
Units:	ppm
Partial Press:	mmHg
-----	
Salinity:	00.0‰
Filter:	5sec
Pressure Units:	bar
Use Press:	At Air Cal
	Custom Setup

The following sub-sections show the initial display screen that appears for each configuration function. Use the flow diagram for oxygen programming at the end of Sec. 6 and the Model 1066 live screen prompts for each function to complete configuration and programming.

### 8.7.1 Oxygen Measurement application

The display screen for programming the measurement is shown. The default value is displayed in bold type. Refer to the Oxygen Programming flow diagram to complete this function.

```

1.234µS/cm 25.0°C
SN Type
Water/Waste
Trace Oxygen
BioRx-Rosemount
BioRx-Other
-----
Brewing
Oxygen In Gas
    
```

### 8.7.2 Units

The display screen for selecting units as ppm , mg/L, ppb, g/L, % Saturation, %Oxygen in Gas, or ppm Oxygen in Gas is shown. The default value is displayed in bold type. Refer to the Oxygen Programming flow diagram to complete this function.

```

1.234µS/cm 25.0°C
SN Units
ppm
mg/L
ppb
µg/L
-----
% Saturation
Partial Pressure
% Oxygen In Gas
ppm Oxygen In Gas
    
```

### 8.7.3 Partial Press

The display screen for selecting pressure units for Partial pressure is shown. This selection is needed if the specified measurement is Partial pressure. The default value is displayed in bold type. Refer to the Oxygen Programming flow diagram to complete this function.

```

1.234µS/cm 25.0°C
SN Partial Press
mm Hg
in Hg
atm
kPa
-----
mbar
bar
    
```

### 8.7.4 Salinity

The display screen for Entering the Salinity (as parts per thousand) of the process liquid to be measured is shown. The default value is displayed in bold type. Refer to the Oxygen Programming flow diagram to complete this function.

Enter Salinity as %

```

1.234µS/cm 25.0°C
SN Salinity
00.0 %
    
```

### 8.7.5 Filter

The display screen for entering the input filter value in seconds is shown. The default value is displayed in bold type. Refer to the Oxygen Programming flow diagram to complete this function.

```

1.234µS/cm 25.0°C
SN Input filter
05 sec
    
```

### 8.7.6 Pressure Units

The display screen for selecting pressure units for atmospheric pressure is shown. This selection is needed for the display of atmospheric pressure. The default value is displayed in bold type. The user must enter a known value for local atmospheric pressure. Refer to the Oxygen Programming flow diagram to complete this function.

```

1.234µS/cm 25.0°C
Pressure Units
mm Hg
in Hg
atm
kPa
-----
mbar
bar
    
```

## 8.8 OZONE Measurement Programming

This section describes how to configure the Model 1066 transmitter for ozone measurement using amperometric ozone sensors. The following programming and configuration functions are covered:

1. Units: ppm Select ppm, mg/L, ppb,  $\mu$ g/L
2. Resolution: 0.001 Select display resolution 0.01 or 0.001
3. Filter: 5sec Override the default input filter, enter 0-999 seconds

To configure Ozone:

1. Press MENU
2. Scroll down to Program. Press ENTER.
3. Scroll down to Measurement. Press ENTER.

1.234 $\mu$ S/cm	25.0°C
SN Configure	
Units:	ppm
Filter:	5 sec
Resolution:	0.001

The adjacent screen format will appear (factory defaults are shown). To program any displayed function, scroll to the desired item and press ENTER.

The following sub-sections show the initial display screen that appears for each configuration function. Use the flow diagram for ozone programming at the end of Sec. 6 and the Model 1066 live screen prompts for each function to complete configuration and programming.

Note: Ozone measurement boards are detected automatically by the analyzer. No measurement selection is necessary.

### 8.8.1 Units

The display screen for selecting measurement units is shown. The default value is displayed in bold type. Refer to the Ozone Programming flow diagram to complete this function.

1.234 $\mu$ S/cm	25.0°C
SN Units	
<b>ppm</b>	
mg/L	
ppb	
$\mu$ g/L	

### 8.8.2 Filter

The display screen for entering the input filter value in seconds is shown. The default value is displayed in bold type. Refer to the Ozone Programming flow diagram to complete this function.

1.234 $\mu$ S/cm	25.0°C
SN Input filter	
<b>05 sec</b>	

### 8.8.3 Resolution

The display screen for selecting display resolution as 0.001 or 0.01 is shown. The default value is displayed in bold type. Refer to the Ozone Programming flow diagram to complete this function.

1.234 $\mu$ S/cm	25.0°C
SN Resolution	
<b>0.001</b>	
0.01	

FIGURE 8-1. Configuring pH/ORP Measurements

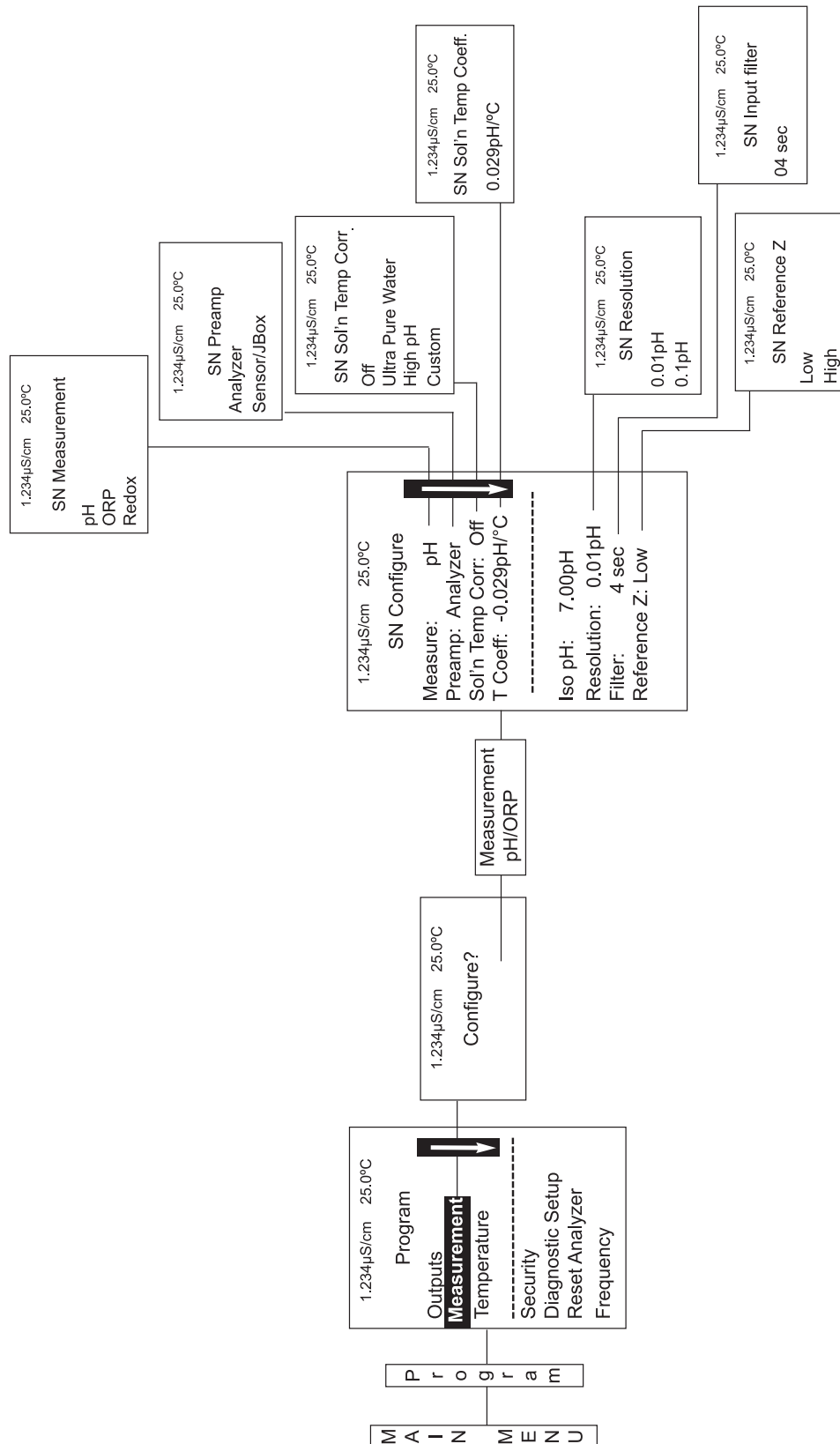

Figure 8-2. Configure Contacting Measurements

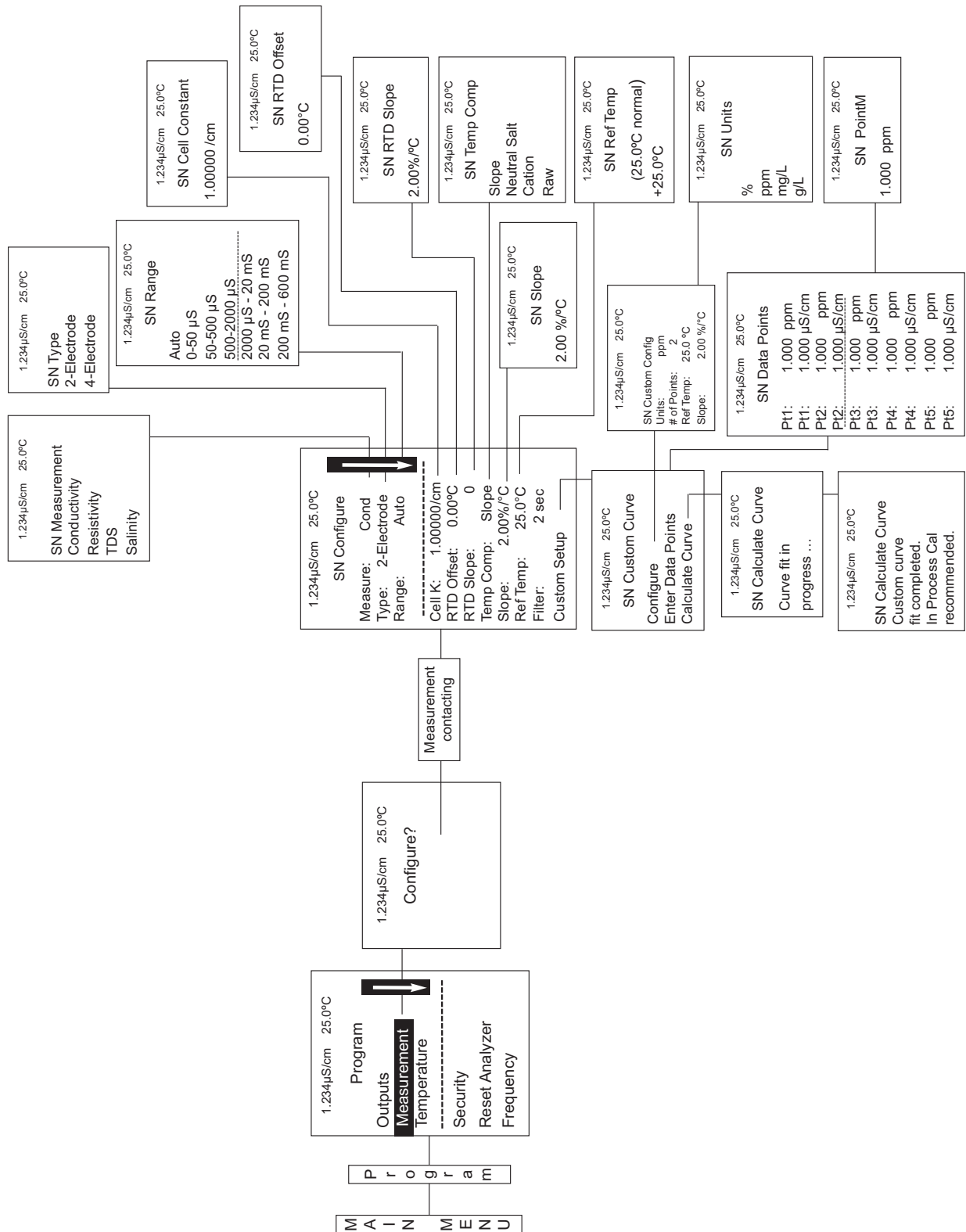

Figure 8-3. Configure Toroidal Measurements

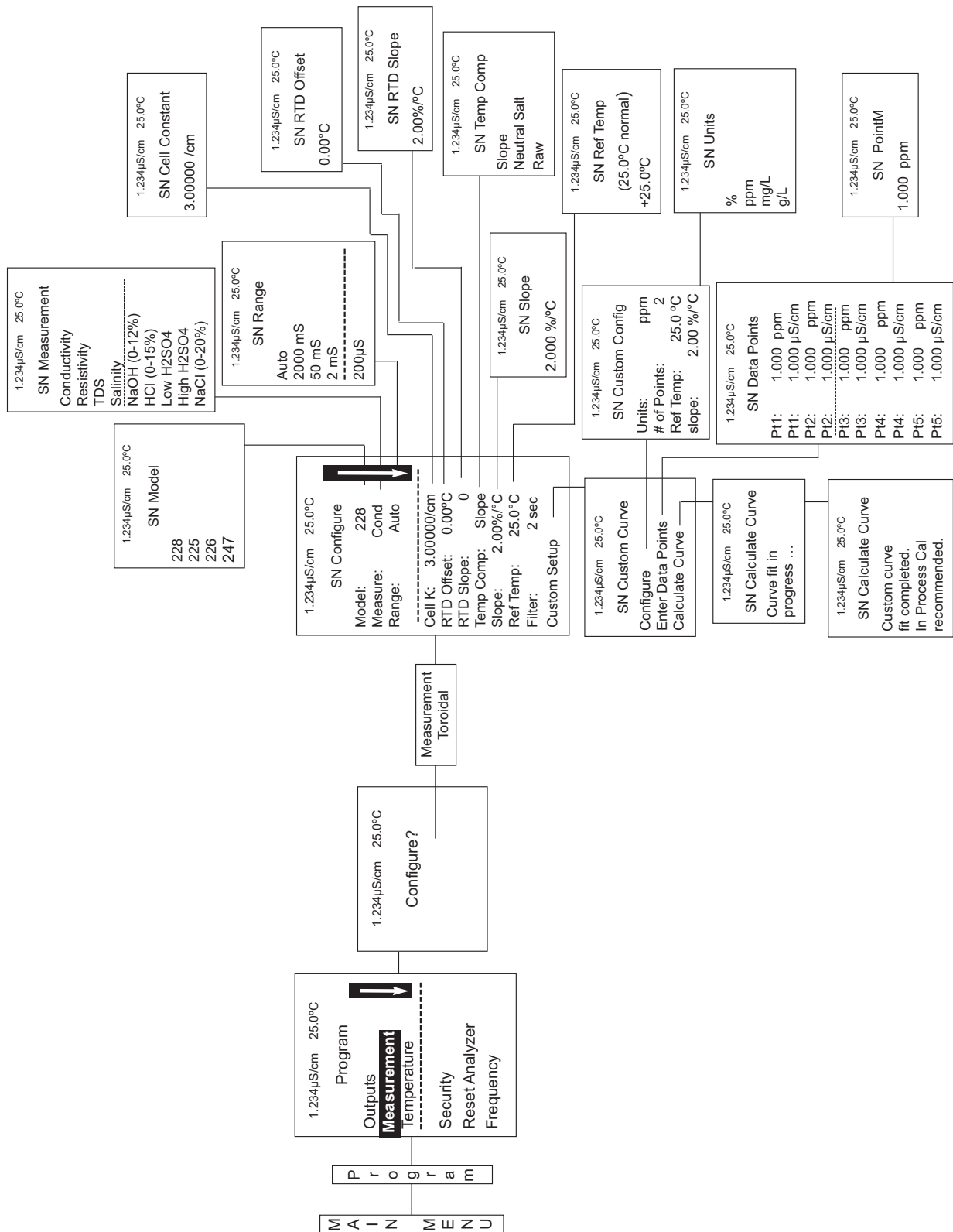

Figure 8-4. Configure Oxygen Measurements

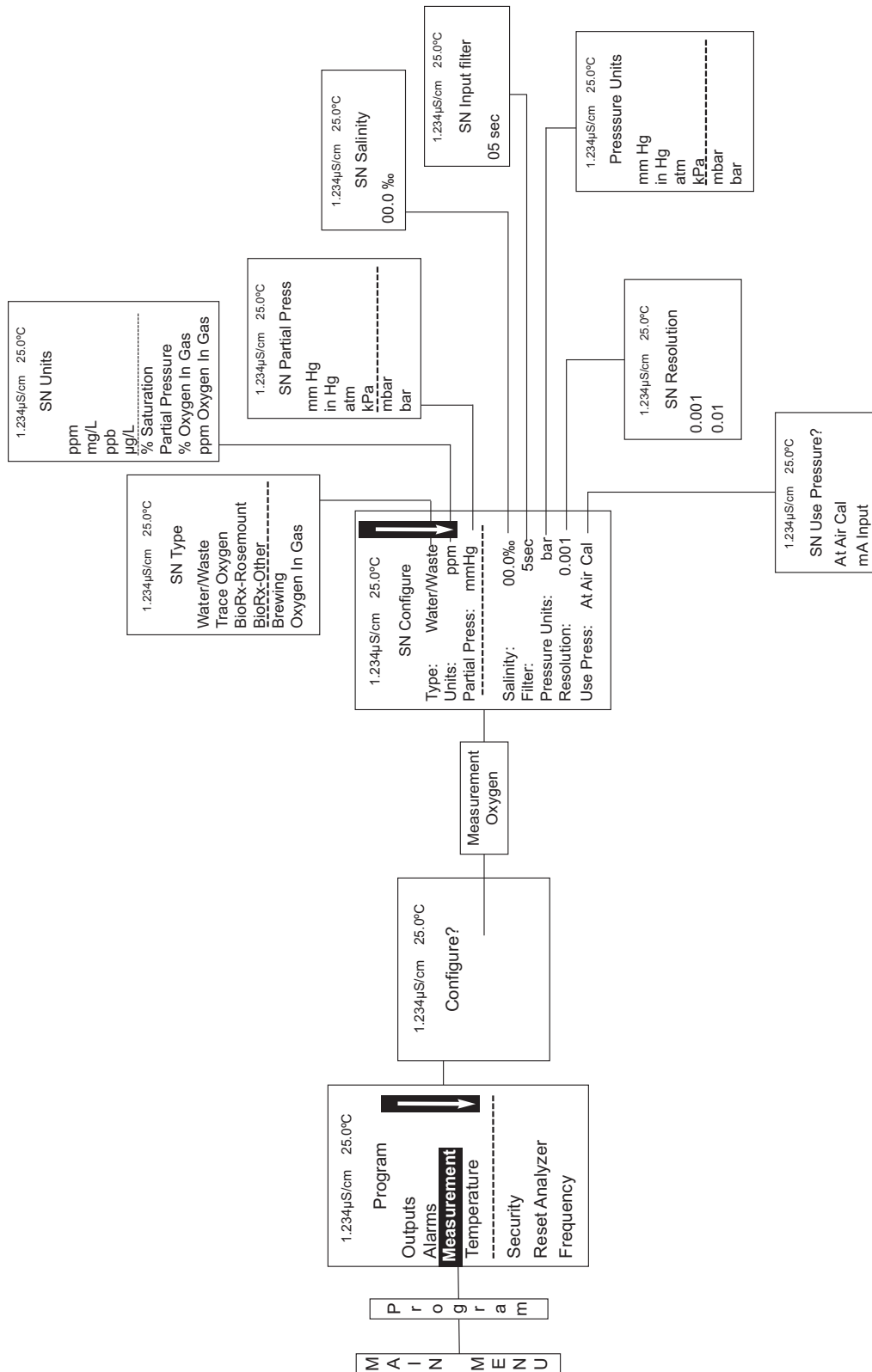

FIGURE 8-5. Configuring Chlorine Measurements

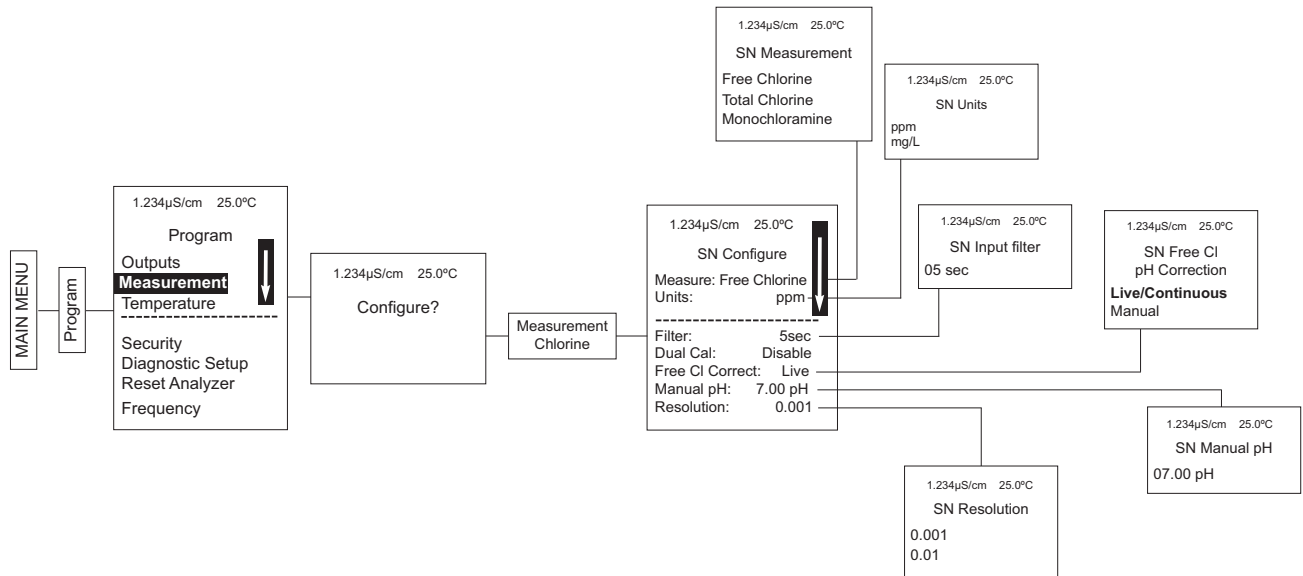
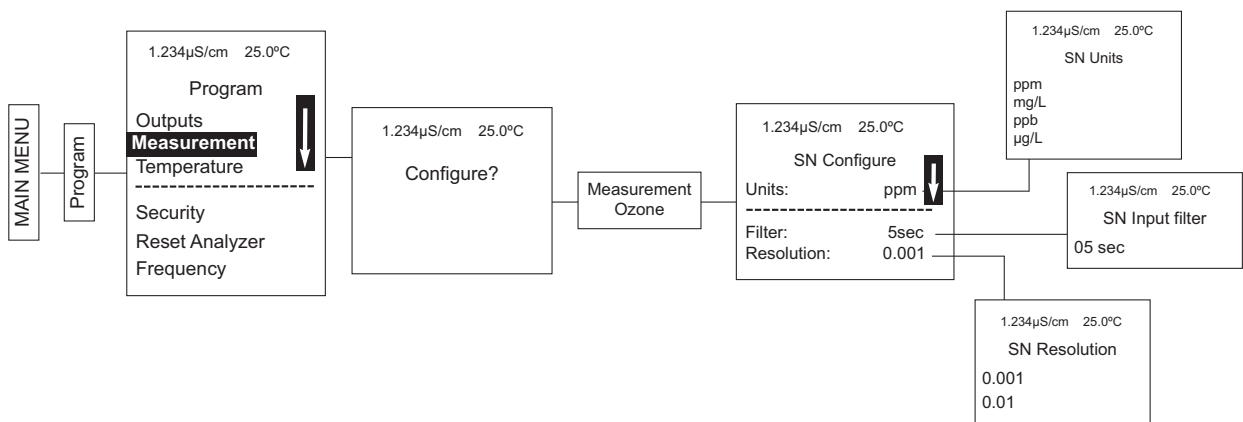

FIGURE 8-5. Configuring Ozone Measurements



# Section 9: Calibration

## 9.1 Introduction

Calibration is the process of adjusting or standardizing the transmitter to a lab test or a calibrated laboratory instrument, or standardizing to some known reference (such as a commercial buffer). The auto-recognition feature of the transmitter will enable the appropriate calibration screens to allow calibration for any configuration of the transmitter. Completion of Quick Start upon first power up enables live measurements but does not ensure accurate readings in the lab or in process. Calibration should be performed with each attached sensor to ensure accurate, repeatable readings.

This section covers the following calibration functions:

1. Auto buffer cal for pH (pH Cal - Sec. 9.2)
2. Manual buffer cal for pH (pH Cal - Sec. 9.2)
3. Set calibration stabilization criteria for pH (pH Cal - Sec. 9.2)
4. Standardization calibration (1-point) for pH, ORP and Redox (pH Cal - Sec. 9.2 and 9.3)
5. SMART sensor auto calibration upload

## 9.2 Calibration

New sensors must be calibrated before use. Regular recalibration is also necessary. Use auto calibration instead of manual calibration. Auto calibration avoids common pitfalls and reduces errors. The transmitter recognizes the buffers and uses temperature-corrected pH values in the calibration. Once the 1066 successfully completes the calibration, it calculates and displays the calibration slope and offset. The slope is reported as the slope at 25°C.

To calibrate the pH loop with a connected pH sensor, access the Calibration screen by pressing ENTER from the main screen and press ENTER.

The following calibration routines are covered:

1. Auto Calibration - pH 2 point buffer calibration with auto buffer recognition
2. Manual Calibration - pH 2 point buffer calibration with manual buffer value entry
3. Standardization - pH 1 point buffer calibration with manual buffer value entry
4. Entering A Known Slope Value - pH Slope calibration with manual entry of known slope value
5. SMART sensor auto calibration – auto detection and upload of cal data

To calibrate pH:

1. Press the **MENU** button
2. Select Calibrate. Press **ENTER**.
3. Select **pH**. Press ENTER.

The following sub-sections show the initial display screen that appears for each calibration routine. Use the **flow diagram for pH calibration** at the end of Sec. 7 and the live screen prompts to complete calibration.

1.234µS/cm 25.0°C
SN Calibrate?
pH
Temperature

## 9.2.1 Auto Calibration

This screen appears after selecting **pH calibration**.

```

1.234µS/cm  25.0°C
      SN pH Cal
Buffer Cal
Standardize
Slope:   59.16mV/pH
Offset:   600 mV
    
```

Note that pH auto calibration criteria can be changed. The following criteria can be adjusted:

- Stabilization time (default 10 sec.)
- Stabilization pH value (default 0.02 pH)
- Type of Buffer used for AUTO CALIBRATION (default is Standard, non-commercial buffers).

The following commercial buffer tables are recognized by the analyzer:

- Standard (NIST plus pH7)
- DIN 19267
- Ingold
- Merck

```

1.234µS/cm  25.0°C
      SN Setup
Stable Time:  10 sec
Stable Delta: 0.02 pH
Buffer:       Standard
    
```

This screen will appear if the auto cal is successful. The screen will return to the pH Buffer Cal Menu.

```

1.234µS/cm  25.0°C
      SN pH Auto Cal
Slope: 59.16 mV/pH
Offset: 60 mV
    
```

The following screens may appear if the auto cal is unsuccessful.

1. A High Slope Error will generate this screen display:

```

1.234µS/cm  25.0°C
      SN pH Auto Cal
High Slope Error
Calculated: 62.11 mV/pH
Max: 62.00 mV/pH
Press EXIT
    
```

2. A Low Slope Error will generate this screen display:

```

1.234µS/cm  25.0°C
      SN pH Auto Cal
Low Slope Error
Calculated: 39.11mV/pH
Min: 40.00 mV/pH
Press EXIT
    
```

3. An Offset Error will generate this screen display:

```

1.234µS/cm  25.0°C
      SN pH Auto Cal
Offset Error
Calculated: 61.22mV
Max: 60.00mV
Press EXIT
    
```

## 9.2.2 Manual Calibration – pH

New sensors must be calibrated before use. Regular recalibration is also necessary. Use manual calibration if non-standard buffers are being used; otherwise, use auto calibration. Auto calibration avoids common pitfalls and reduces errors. The adjacent appears after selecting Manual pH calibration.

```
1.234µS/cm 25.0°C  
SN pH Manual Cal  
Buffer 1  
Buffer 2
```

## 9.2.3 Entering a Known Slope Value – pH

If the electrode slope is known from other measurements, it can be entered directly in the 1066 transmitter. The slope must be entered as the slope at 25°C.

```
1.234µS/cm 25.0°C  
SN pH Slope@25°C  
59.16 mV/pH
```

## 9.2.4 Standardization – pH

The pH measured by the 1066 transmitter can be changed to match the reading from a second or referee instrument. The process of making the two readings agree is called standardization. During standardization, the difference between the two pH values is converted to the equivalent voltage. The voltage, called the reference offset, is added to all subsequent measured cell voltages before they are converted to pH. If a standardized sensor is placed in a buffer solution, the measured pH will differ from the buffer pH by an amount equivalent to the standardization offset.

```
1.234µS/cm 25.0°C  
SN Enter Value  
07.00pH
```

This screen may appear if pH Cal is unsuccessful. An Offset Error will generate this screen display:

```
1.234µS/cm 25.0°C  
SN Standardize  
Offset Error  
Calculated: 96mV  
Max: 60mV  
Press EXIT
```

If the pH Cal is successful, the screen will return to the Cal sub-menu.

## 9.2.5 SMART sensor auto calibration upload – pH

All calibration data including slope (mV/pH unit), offset (mV), glass impedance (MegOhms), and reference impedance (kOhms) is automatically downloaded to the SMART sensor upon successful calibration. This data transfer to the sensor is transparent and does not require any user action. Calibrated SMART sensors will be loop-calibrated when wired or attached (via VP8 cable connection) to any SMART-enabled Rosemount Analytical instrument.

To calibrate any SMART sensor, choose any available calibration method. Note that new SMART sensors upon first shipment from Emerson are pre-calibrated and do not require buffer calibration or standardization to be used in process immediately.

## 9.3 ORP and Redox Calibration

For process control, it is often important to make the measured ORP or Redox agree with the ORP or Redox of a standard solution. During calibration, the measured ORP or Redox is made equal to the ORP or Redox of a standard solution at a single point.

To calibrate the ORP loop with a connected ORP sensor, access the Calibration screen by pressing ENTER from the main screen and press ENTER.

The following calibration routine is covered:

1. Standardization ORP 1 point buffer calibration with manual buffer value entry.

To calibrate ORP:

1. Press the MENU button.
2. Select Calibrate. Press ENTER.
3. Select ORP and Redox. Press ENTER.

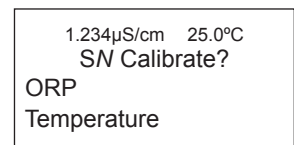

1.234 $\mu$ S/cm 25.0°C  
SN Calibrate?  
ORP  
Temperature

The following sub-sections show the initial display screen that appears for each calibration routine. Use the **flow diagram for ORP calibration** at the end of Sec. 8 and the live screen prompts to complete calibration.

### 9.3.1 Standardization – ORP and Redox

For process control, it is often important to make the measured ORP and Redox agree with the ORP and Redox of a standard solution. During calibration, the measured ORP and Redox is made equal to the ORP and Redox of a standard solution at a single point. This screen appears after selecting ORP and Redox calibration:

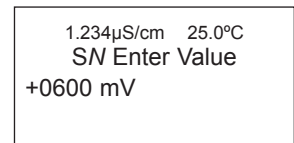

1.234 $\mu$ S/cm 25.0°C  
SN Enter Value  
+0600 mV

If the ORP and Redox Cal is successful, the screen will return to the Cal sub-menu.

The following screen may appear if ORP and Redox Cal is unsuccessful.

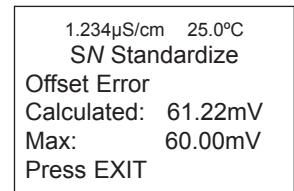

1.234 $\mu$ S/cm 25.0°C  
SN Standardize  
Offset Error  
Calculated: 61.22mV  
Max: 60.00mV  
Press EXIT

## 9.4 Contacting Conductivity Calibration

New conductivity sensors rarely need calibration. The cell constant printed on the label is sufficiently accurate for most applications.

### CALIBRATING AN IN-SERVICE CONDUCTIVITY SENSOR

After a conductivity sensor has been in service for a period of time, recalibration may be necessary. There are three ways to calibrate a sensor.

- a. Use a standard instrument and sensor to measure the conductivity of the process stream. It is not necessary to remove the sensor from the process piping. The temperature correction used by the standard instrument may not exactly match the temperature correction used by the Model 1066. To avoid errors, turn off temperature correction in both the transmitter and the standard instrument.
- b. Place the sensor in a solution of known conductivity and make the transmitter reading match the conductivity of the standard solution. Use this method if the sensor can be easily removed from the process piping and a standard is available. Be careful using standard solutions having conductivity less than 100 S/cm. Low conductivity standards are highly susceptible to atmospheric contamination. Avoid calibrating sensors with 0.01/cm cell constants against conductivity standards having conductivity greater than 100 S/cm. The resistance of these solutions may be too low for an accurate measurement. Calibrate sensors with 0.01/cm cell constant using method c.
- c. To calibrate a 0.01/cm sensor, check it against a standard instrument and 0.01/cm sensor while both sensors are measuring water having a conductivity between 5 and 10 S/cm. To avoid drift caused by absorption of atmospheric carbon dioxide, saturate the sample with air before making the measurements. To ensure adequate flow past the sensor during calibration, take the sample downstream from the sensor. For best results, use a flow-through standard cell. If the process temperature is much different from ambient, keep connecting lines short and insulate the flow cell.

To calibrate the conductivity loop with a connected contacting conductivity sensor, access the Calibration screen by pressing ENTER from the main screen and press ENTER.

The following calibration routines are covered:

1. Zero Cal Zero the transmitter with the sensor attached
2. In Process Cal Standardize the sensor to a known conductivity
3. Cell K: 1.00000/cm Enter the cell Constant for the sensor
4. Meter Cal Calibrate the transmitter to a lab conductivity instrument
5. Cal Factor: 0.95000/cm Enter the Cal Factor for 4-Electrode sensors from the sensor tag

To calibrate contacting conductivity:

1. Press the MENU button
2. Select Calibrate. Press ENTER.
3. Select Conductivity. Press ENTER.

1.234µS/cm 25.0°C SN Calibrate? Conductivity Temperature
---

The adjacent screen will appear. To calibrate Conductivity or Temperature, scroll to the desired item and press ENTER.

The following sub-sections show the initial display screen that appears for each calibration routine. Use the flow diagram for Conductivity calibration at the end of Sec. 7 and the live screen prompts for each routine to complete calibration.

The adjacent screen appears after selecting Conductivity calibration:

```
1.234µS/cm 25.0°C
SN Calibration
Zero Cal
In Process Cal
Meter Cal
Cell K: 1.00000/cm
```

### 9.4.1 Entering the Cell Constant

New conductivity sensors rarely need calibration. The cell constant printed on the label is sufficiently accurate for most applications. The cell constant should be entered:

- When the unit is installed for the first time
- When the probe is replaced

The display screen for entering a cell Constant for the sensor is shown. The default value is displayed in bold type.

```
1.234µS/cm 25.0°C
SN Cell Constant
1.00000 /cm
```

### 9.4.2 Zeroing the Instrument

This procedure is used to compensate for small offsets to the conductivity signal that are present even when there is no conductivity to be measured. This procedure is affected by the length of extension cable and should always be repeated if any changes in extension cable or sensor have been made. Electrically connect the conductivity probe as it will actually be used and place the measuring portion of the probe in air. Be sure the probe is dry.

The adjacent screen will appear after selecting Zero Cal from the Conductivity Calibration screen:

The adjacent screen will appear if zero Cal is successful. The screen will return to the conductivity Cal Menu.

The adjacent screen may appear if zero Cal is unsuccessful.

```
1.234µS/cm 25.0°C
SN Zero Cal
In Air
In Water
```

```
1.234µS/cm 25.0°C
SN Zero Cal
Sensor Zero Done
```

```
1.234µS/cm 25.0°C
SN Zero Cal
Sensor Zero Fail
Offset too high
```

```
Press EXIT
```

### 9.4.3 Calibrating the Sensor in a Conductivity Standard (in process cal)

This procedure is used to calibrate the sensor and transmitter against a solution of known conductivity. This is done by submerging the probe in the sample of known conductivity, then adjusting the displayed value, if necessary, to correspond to the conductivity value of the sample. Turn temperature correction off and use the conductivity of the standard. Use a calibrated thermometer to measure temperature. The probe must be cleaned before performing this procedure.

The adjacent screen will appear after selecting In Process Cal from the Conductivity Calibration screen:

The adjacent screen will appear if In Process Cal is successful. The screen will return to the conductivity Cal Menu.

The adjacent screen may appear if In Process Cal is unsuccessful. The screen will return to the conductivity Cal Menu.

```
1.234µS/cm 25.0°C
SN InProcess Cal
Wait for stable
reading.
```

The adjacent screen will appear if In Process Cal is successful. The screen will return to the conductivity Cal Menu.

```
1.234µS/cm 25.0°C  
SN InProcess Cal  
Updated cell  
constant:  
1.00135/cm
```

The adjacent screen may appear if In Process Cal is unsuccessful. The screen will return to the conductivity Cal Menu.

```
1.234µS/cm 25.0°C  
SN InProcess Cal  
Calibration  
Error  
  
Press EXIT
```

## 9.4.4 Calibrating the Sensor To A Laboratory Instrument (meter cal)

This procedure is used to check and correct the conductivity reading of the Model 1066 using a laboratory conductivity instrument. This is done by submerging the conductivity probe in a bath and measuring the conductivity of a grab sample of the same bath water with a separate laboratory instrument. The Model 1066 reading is then adjusted to match the conductivity reading of the lab instrument.

The adjacent screen will appear after selecting **Meter Cal** from the Conductivity Calibration screen:

```
1.234µS/cm 25.0°C  
SN Meter Cal  
Use precision  
resistors only
```

After pressing ENTER, the display shows the live value measured by the sensor

```
1.234µS/cm 25.0°C  
SN Enter Value  
xx.xx kΩ
```

If the meter cal is successful the screen will return to the conductivity Cal Menu.

```
1.234µS/cm 25.0°C  
SN Meter Cal  
Calibration  
Error  
  
Press EXIT
```

The adjacent screen will appear if Meter Cal is unsuccessful. The screen will return to the conductivity Cal Menu.

## 9.4.5 Cal Factor

Upon initial installation and power up, if **4-electrode** was selected for the sensor type in the **Quick Start** menus, the user enters a Cell Constant and a “Cal Factor” using the instrument keypad. The cell constant is needed to convert measured conductance to conductivity as displayed on the transmitter screen. The “Cal Factor” entry is needed increase the accuracy of the live conductivity readings, especially at low conductivity readings below 20uS/cm. Both the Cell Constant and the “Cal Factor” are printed on the tag attached to the 4-electrode sensor/cable.

```
1.234µS/cm 25.0°C  
SN Cal Factor  
0.95000 /cm
```

## 9.5 Toroidal Conductivity Calibration

Calibration is the process of adjusting or standardizing the transmitter to a lab test or a calibrated laboratory instrument, or standardizing to some known reference (such as a conductivity standard). This section contains procedures for the first time use and for routine calibration of the Model 1066 transmitter.

To calibrate the conductivity loop with a connected contacting conductivity sensor, access the Calibration screen by pressing ENTER from the main screen and press ENTER.

The following calibration routines are covered:

1. Zero Cal Zero the transmitter with the sensor attached
2. In Process Cal Standardize the sensor to a known conductivity
3. Cell K: 1.00000/cm Enter the cell Constant for the sensor
4. Meter Cal Calibrate the transmitter to a lab conductivity instrument

To calibrate toroidal conductivity:

1. Press the MENU button
2. Select Calibrate. Press ENTER.
3. Select Conductivity. Press ENTER.

The adjacent screen will appear. To calibrate Toroidal Conductivity or Temperature, scroll to the desired item and press ENTER

1.234 $\mu$ S/cm 25.0°C SN Calibrate? Conductivity Temperature
---

The following sub-sections show the initial display screen that appears for each calibration routine. Use the flow diagram for Conductivity calibration at the end of Sec. 7 and the live screen prompts to complete calibration.

The adjacent screen appears after selecting Conductivity calibration:

1.234 $\mu$ S/cm 25.0°C SN Calibration Zero Cal In Process Cal Cell K: 1.00000/cm
---

### 9.5.1 Entering the Cell Constant

New conductivity sensors rarely need calibration. The cell constant printed on the label is sufficiently accurate for most applications. The cell constant should be entered:

- When the unit is installed for the first time
- When the probe is replaced
- During troubleshooting

This procedure sets up the transmitter for the probe type connected to the transmitter. Each type of probe has a specific cell constant

The display screen for entering a cell constant for the sensor is shown. The default value is displayed in bold type.

1.234 $\mu$ S/cm 25.0°C SN Cell Constant <b>3.00000</b> /cm
---

## 9.5.2 Zeroing the Instrument

This procedure is used to compensate for small offsets to the conductivity signal that are present even when there is no conductivity to be measured. This procedure is affected by the length of extension cable and should always be repeated if any changes in extension cable or sensor have been made. Electrically connect the conductivity probe as it will actually be used and place the measuring portion of the probe in air.

The adjacent screen will appear after selecting Zero Cal from the Conductivity Calibration screen:

```
1.234µS/cm  25.0°C
SN Zero Cal
In Air
In Water
```

The adjacent screen will appear if zero Cal is successful. The screen will return to the conductivity Cal Menu.

```
1.234µS/cm  25.0°C
SN Zero Cal
Sensor Zero Done
```

The adjacent screen may appear if zero Cal is unsuccessful.

```
1.234µS/cm  25.0°C
SN Zero Cal
Sensor Zero Fail
Offset too high

Press EXIT
```

## 9.5.3 Calibrating the Sensor in a Conductivity Standard (in process cal)

This procedure is used to check and correct the conductivity reading of the Model 1066 to ensure that the reading is accurate. This is done by submerging the probe in the sample of known conductivity, then adjusting the displayed value, if necessary, to correspond to the conductivity value of the sample. The probe must be cleaned before performing this procedure. The temperature reading must also be checked and standardized if necessary, prior to performing this procedure.

The adjacent screen will appear after selecting In Process Cal from the Conductivity Calibration screen:

```
1.234µS/cm  25.0°C
SN InProcess Cal
Wait for stable
reading.
```

The following screen will appear if In Process Cal is successful. The screen will return to the conductivity Cal Menu.

```
1.234µS/cm  25.0°C
SN InProcess Cal
Updated cell
constant:
3.01350/cm
```

This screen may appear if In Process Cal is unsuccessful. The screen will return to the conductivity Cal Menu.

```
1.234µS/cm  25.0°C
SN InProcess Cal
Calibration
Error

Press EXIT
```

## 9.6 Calibration – Chlorine

Model 1066 can measure three variants of Chlorine:

- Free Chlorine
- Total Chlorine
- Monochloramine

The section describes how to calibrate any compatible amperometric chlorine sensor. The following calibration routines are covered in the family of supported Chlorine sensors:

- Air Cal
- Zero Cal
- In Process Cal

### 9.6.1 Calibration – Free Chlorine

A free chlorine sensor generates a current directly proportional to the concentration of free chlorine in the sample. Calibrating the sensor requires exposing it to a solution containing no chlorine (zero standard) and to a solution containing a known amount of chlorine (full-scale standard). The zero calibration is necessary because chlorine sensors, even when no chlorine is in the sample, generate a small current called the residual current. The transmitter compensates for the residual current by subtracting it from the measured current before converting the result to a chlorine value. New sensors require zeroing before being placed in service, and sensors should be zeroed whenever the electrolyte solution is replaced.

To calibrate the chlorine sensor, access the Calibration screen by pressing ENTER from the main screen and press ENTER.

The following calibration routines are covered:

1. Zero Cal Zeroing the sensor in solution with zero free chlorine
2. Grab Cal Standardizing to a sample of known free chlorine concentration

To calibrate free chlorine:

1. Press the MENU button
2. Select Calibrate. Press ENTER.
3. Select Free Chlorine. Press ENTER.

The adjacent screen will appear. To calibrate Free Chlorine or Temperature, scroll to the desired item and press ENTER.

1.234 $\mu$ S/cm 25.0°C SN Calibrate? Free Chlorine Temperature
--

The following sub-sections show the initial display screen that appears for each calibration routine. Use the flow diagram for Chlorine calibration at the end of Sec. 7 and the live screen prompts to complete calibration.

The adjacent screen appears after selecting Free Chlorine calibration:

1.234 $\mu$ S/cm 25.0°C SN Calibration Zero Cal In Process Cal
---

### 9.6.1.1 Zeroing the Sensor

The adjacent screen will appear during Zero Cal. Be sure sensor has been running in zero solution for at least two hours before starting zero step.

```
1.234µS/cm 25.0°C
SN Zero Cal
Zeroing
Wait
```

The adjacent screen will appear if In Zero Cal is successful. The screen will return to the Amperometric Cal Menu.

```
1.234µS/cm 25.0°C
SN Zero Cal
Sensor zero done
```

The adjacent screen may appear if In Zero Cal is unsuccessful. The screen will return to the Amperometric Cal Menu.

```
1.234µS/cm 25.0°C
SN Zero Cal
Sensor zero failed

Press EXIT
```

### 9.6.1.2 In Process Calibration

The adjacent screen will appear prior to In Process Cal

```
1.234µS/cm 25.0°C
SN InProcess Cal
Wait for stable
reading.
```

If the In Process Cal is successful, the screen will return to the Cal sub-menu.

The adjacent screen may appear if In Zero Cal is unsuccessful. The screen will return to the Amperometric Cal Menu.

```
1.234µS/cm 25.0°C
SN InProcess Cal
Calibration
Error

Press EXIT
```

## 9.6.2 Calibration – Total Chlorine

Total chlorine is the sum of free and combined chlorine. The continuous determination of total chlorine requires two steps. First, the sample flows into a conditioning system (TCL) where a pump continuously adds acetic acid and potassium iodide to the sample. The acid lowers the pH, which allows total chlorine in the sample to quantitatively oxidize the iodide in the reagent to iodine. In the second step, the treated sample flows to the sensor. The sensor is a membrane-covered amperometric sensor, whose output is proportional to the concentration of iodine. Because the concentration of iodine is proportional to the concentration of total chlorine, the transmitter can be calibrated to read total chlorine. Because the sensor really measures iodine, calibrating the sensor requires exposing it to a solution containing no iodine (zero standard) and to a solution containing a known amount of iodine (full-scale standard). The Zero calibration is necessary because the sensor, even when no iodine is present, generates a small current called the residual current. The transmitter compensates for the residual current by subtracting it from the measured current before converting the result to a total chlorine value. New sensors require zeroing before being placed in service, and sensors should be zeroed whenever the electrolyte solution is replaced. The best zero standard is deionized water. The purpose of the In Process Calibration is to establish the

slope of the calibration curve. Because stable total chlorine standards do not exist, the sensor must be calibrated against a test run on a grab sample of the process liquid. Several manufacturers offer portable test kits for this purpose.

To calibrate the chlorine sensor, access the Calibration screen by pressing ENTER from the main screen, and press ENTER.

The following calibration routines are covered:

1. Zero Cal Zeroing the sensor in solution with zero total chlorine
2. Grab Cal Standardizing to a sample of known total chlorine concentration

To calibrate total chlorine:

1. Press the MENU button
2. Select Calibrate. Press ENTER.
3. Select Total Chlorine. Press ENTER.

The adjacent screen will appear. To calibrate Total Chlorine or Temperature, scroll to the desired item and press ENTER

```
1.234µS/cm 25.0°C
SN Calibrate?
Total Chlorine
Temperature
```

The following sub-sections provide you with the initial display screen that appears for each calibration routine. Use the flow diagram for Chlorine calibration at the end of Sec. 9 and the live screen prompts to complete calibration.

This adjacent screen appears after selecting Total Chlorine calibration:

```
1.234µS/cm 25.0°C
SN Calibration
Zero Cal
In Process Cal
```

### 9.6.2.1 Zeroing the Sensor

The adjacent screen will appear during Zero Cal. Be sure sensor has been running in zero solution for at least two hours before starting zero step.

```
1.234µS/cm 25.0°C
SN Zero Cal
Zeroing
Wait
```

The adjacent screen will appear if In Zero Cal is successful. The screen will return to the Amperometric Cal Menu.

```
1.234µS/cm 25.0°C
SN Zero Cal
Sensor zero done
```

The adjacent screen may appear if In Zero Cal is unsuccessful. The screen will return to the Amperometric Cal Menu.

```
1.234µS/cm 25.0°C
SN Zero Cal
Sensor zero failed

Press EXIT
```

### 9.6.2.2 In Process Calibration

The adjacent screen will appear prior to In Process Cal

If the In Process Cal is successful, the screen will return to the Cal sub-menu.

```
1.234µS/cm 25.0°C
SN InProcess Cal
Wait for stable
reading.
```

The adjacent screen may appear if In Process Cal is unsuccessful. The screen will return to the Amperometric Cal Menu.

```
1.234µS/cm 25.0°C
SN InProcess Cal
Calibration error

Press EXIT
```

### 9.6.3 Calibration – Monochloramine

A monochloramine sensor generates a current directly proportional to the concentration of monochloramine in the sample. Calibrating the sensor requires exposing it to a solution containing no monochloramine (zero standard) and to a solution containing a known amount of monochloramine (full-scale standard). The Zero calibration is necessary because monochloramine sensors, even when no monochloramine is in the sample, generate a small current called the residual or zero current. The transmitter compensates for the residual current by subtracting it from the measured current before converting the result to a monochloramine value. New sensors require zeroing before being placed in service, and sensors should be zeroed whenever the electrolyte solution is replaced. The best zero standard is deionized water. The purpose of the In Process calibration is to establish the slope of the calibration curve. Because stable monochloramine standards do not exist, the sensor must be calibrated against a test run on a grab sample of the process liquid. Several manufacturers offer portable test kits for this purpose.

To calibrate the chlorine sensor, access the Calibration screen by pressing ENTER from the main screen, and press ENTER.

The following calibration routines are covered:

1. Zero Cal Zeroing the sensor in solution with zero total chlorine
2. Grab Cal Standardizing to a sample of known monochloramine concentration

To calibrate monochloramine:

1. Press the MENU button
2. Select Calibrate. Press ENTER.
3. Select Monochloramine. Press ENTER.

The adjacent screen will appear. To calibrate Monochloramine or Temperature, scroll to the desired item and press ENTER.

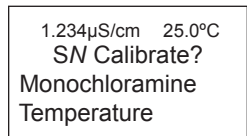

1.234µS/cm 25.0°C  
SN Calibrate?  
Monochloramine  
Temperature

The following sub-sections provide you with the initial display screen that appears for each calibration routine. Use the flow diagram for Chlorine calibration at the end of Sec. 9 and the live screen prompts to complete calibration.

The adjacent screen appears after selecting Monochloramine calibration:

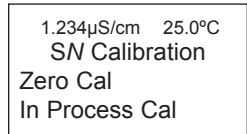

1.234µS/cm 25.0°C  
SN Calibration  
Zero Cal  
In Process Cal

### 9.6.4 Zeroing the Sensor

The adjacent screen will appear during Zero Cal. Be sure sensor has been running in zero solution for at least two hours before starting zero step.

```
1.234µS/cm  25.0°C  
SN Zero Cal  
Zeroing  
Wait
```

The adjacent screen will appear if In Zero Cal is successful. The screen will return to the Amperometric Cal Menu.

```
1.234µS/cm  25.0°C  
SN Zero Cal  
Sensor zero done
```

The adjacent screen may appear if In Zero Cal is unsuccessful. The screen will return to the Amperometric Cal Menu.

```
1.234µS/cm  25.0°C  
SN Zero Cal  
Sensor zero failed  
  
Press EXIT
```

### 9.6.5 In Process Calibration

The adjacent screen will appear prior to In Process Cal

If the In Process Cal is successful, the screen will return to the Cal sub-menu.

```
1.234µS/cm  25.0°C  
SN InProcess Cal  
Wait for stable  
reading.
```

The adjacent screen may appear if In Process Cal is unsuccessful. The screen will return to the Amperometric Cal Menu.

```
1.234µS/cm  25.0°C  
SN InProcess Cal  
Calibration  
Error  
  
Press EXIT
```

## 9.7 Calibration – Oxygen

Oxygen sensors generate a current directly proportional to the concentration of dissolved oxygen in the sample. Calibrating the sensor requires exposing it to a solution containing no oxygen (zero standard) and to a solution containing a known amount of oxygen (full-scale standard). The Zero Calibration is necessary because oxygen sensors, even when no oxygen is present in the sample, generate a small current called the residual current. The transmitter compensates for the residual current by subtracting it from the measured current before converting the result to a dissolved oxygen value. New sensors require zeroing before being placed in service, and sensors should be zeroed whenever the electrolyte solution is replaced. The recommended zero standard is 5% sodium sulfite in water, although oxygen-free nitrogen can also be used. The Model 499A TrDO sensor, used for the determination of trace (ppb) oxygen levels, has very low residual current and does not normally require zeroing. The residual current in the 499A TrDO sensor is equivalent to less than 0.5 ppb oxygen. The purpose of the In Process Calibration is to establish the slope of the calibration curve. Because the solubility of atmospheric oxygen in water as a function of temperature and barometric pressure is well known, the natural choice for a full-scale standard is air-saturated water. However, air-saturated water is difficult to prepare and use, so the universal practice is to use air for calibration. From the point of view of the oxygen sensor, air and air-saturated water are

identical. The equivalence comes about because the sensor really measures the chemical potential of oxygen. Chemical potential is the force that causes oxygen molecules to diffuse from the sample into the sensor where they can be measured. It is also the force that causes oxygen molecules in air to dissolve in water and to continue to dissolve until the water is saturated with oxygen. Once the water is saturated, the chemical potential of oxygen in the two phases (air and water) is the same. Oxygen sensors generate a current directly proportional to the rate at which oxygen molecules diffuse through a membrane stretched over the end of the sensor. The diffusion rate depends on the difference in chemical potential between oxygen in the sensor and oxygen in the sample. An electrochemical reaction, which destroys any oxygen molecules entering the sensor, keeps the concentration (and the chemical potential) of oxygen inside the sensor equal to zero. Therefore, the chemical potential of oxygen in the sample alone determines the diffusion rate and the sensor current. When the sensor is calibrated, the chemical potential of oxygen in the standard determines the sensor current. Whether the sensor is calibrated in air or air-saturated water is immaterial. The chemical potential of oxygen is the same in either phase. Normally, to make the calculation of solubility in common units (like ppm DO) simpler, it is convenient to use water-saturated air for calibration. Automatic air calibration is standard. The user simply exposes the sensor to water-saturated air. The transmitter monitors the sensor current. When the current is stable, the transmitter stores the current and measures the temperature using a temperature element inside the oxygen sensor. The user must enter the barometric pressure. From the temperature the transmitter calculates the saturation vapor pressure of water. Next, it calculates the pressure of dry air by subtracting the vapor pressure from the barometric pressure. Using the fact that dry air always contains 20.95% oxygen, the transmitter calculates the partial pressure of oxygen. Once the transmitter knows the partial pressure of oxygen, it uses the Bunsen coefficient to calculate the equilibrium solubility of atmospheric oxygen in water at the prevailing temperature. At 25°C and 760 mm Hg, the equilibrium solubility is 8.24 ppm. Often it is too difficult or messy to remove the sensor from the process liquid for calibration. In this case, the sensor can be calibrated against a measurement made with a portable laboratory instrument. The laboratory instrument typically uses a membrane-covered amperometric sensor that has been calibrated against water-saturated air.

To calibrate the oxygen sensor, access the Calibration screen by pressing ENTER from the main screen, select and press ENTER.

The following calibration routines are covered:

1. Zero Cal Zeroing the sensor in a medium with zero oxygen
2. Air Cal Calibrating the sensor in a water-saturated air sample
3. In Process Cal Standardizing to a sample of known oxygen concentration
4. Sen@ 25°C:2500nA/ppm Entering a known slope value for sensor response

To calibrate oxygen:

1. Press the MENU button
2. Select Calibrate. Press ENTER.
3. Select Oxygen. Press ENTER.

The adjacent screen will appear. To calibrate Oxygen or Temperature, scroll to the desired item and press ENTER

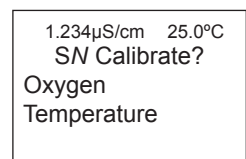

The following sub-sections provide you with the initial display screen that appears for each calibration routine. Use the flow diagram for Oxygen calibration at the end of Sec. 9 and the live screen prompts for each routine to complete calibration.

The adjacent screen appears after selecting Oxygen calibration:

```

1.234µS/cm  25.0°C
      SN Calibration
Air Cal
Zero Cal
In Process Cal
Sen@ 25°C:2500nA/ppm
Zero Current: 1234nA
    
```

Air calibration criteria can be changed.

The following criteria can be adjusted:

- Stabilization time (default 10 sec.)
- Stabilization pH value (default 0.05 ppm)
- Salinity of the solution to be measured (default 00.0 parts per thousand)

The adjacent screen will appear to allow adjustment of these criteria:

```

1.234µS/cm  25.0°C
      SN Setup
Stable Time: 10 sec
Stable Delta: 0.05 ppm
Salinity:  00.0 ‰
    
```

## 9.7.1 Zeroing the Sensor

The adjacent screen will appear during Zero Cal

```

1.234 nA
      SN Zero Cal
Zeroing
Wait
    
```

The adjacent screen will appear if In Zero Cal is successful. The screen will return to the Amperometric Cal Menu.

```

1.234 nA
      SN Zero Cal
Sensor zero done
    
```

The adjacent screen may appear if In Zero Cal is unsuccessful. The screen will return to the Amperometric Cal Menu.

```

1.234 nA
      SN Zero Cal
Sensor zero failed

Press EXIT
    
```

## 9.7.2 Calibrating the Sensor in Air

The adjacent screen will appear prior to Air Cal

```

1.234µS/cm  25.0°C
      SN Air Cal
Start Calibration
Setup
    
```

The adjacent screen will appear if In Air Cal is successful. The screen will return to the Amperometric Cal Menu.

```

1.234µS/cm  25.0°C
      SN Air Cal
Done
    
```

The adjacent screen may appear if In Air Cal is unsuccessful. The screen will return to the Amperometric Cal Menu.

```

1.234µS/cm  25.0°C
      SN Air Cal
Failure
Check Sensor

Press EXIT
    
```

### 9.7.3 Calibrating the Sensor Against A Standard Instrument (in process cal)

The adjacent screen will appear prior to In Process Cal

If the In Process Cal is successful, the screen will return to the Cal sub-menu.

The adjacent screen may appear if In Zero Cal is unsuccessful. The screen will return to the Amperometric Cal Menu.

## 9.8 Calibration – Ozone

An ozone sensor generates a current directly proportional to the concentration of ozone in the sample. Calibrating the sensor requires exposing it to a solution containing no ozone (zero standard) and to a solution containing a known amount of ozone (full-scale standard). The Zero Calibration is necessary because ozone sensors, even when no ozone is in the sample, generate a small current called the residual or zero current. The transmitter compensates for the residual current by subtracting it from the measured current before converting the result to an ozone value. New sensors require zeroing before being placed in service, and sensors should be zeroed whenever the electrolyte solution is replaced. The best zero standard is deionized water. The purpose of the In Process Calibration is to establish the slope of the calibration curve. Because stable ozone standards do not exist, the sensor must be calibrated against a test run on a grab sample of the process liquid. Several manufacturers offer portable test kits for this purpose.

To calibrate the ozone sensor, access the Calibration screen by pressing ENTER from the main screen, select and press ENTER.

The following calibration routines are covered:

1. Zero Cal Zeroing the sensor in solution with zero total chlorine
2. Grab Cal Standardizing to a sample of known ozone concentration

To calibrate ozone:

1. Press the MENU button
2. Select Calibrate. Press ENTER.
3. Select Ozone. Press ENTER.

The adjacent screen will appear. To calibrate Ozone or Temperature, scroll to the desired item and press ENTER.

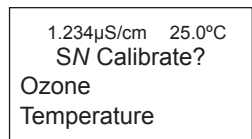

The following sub-sections provide you with the initial display screen that appears for each calibration routine. Use the **flow diagram for Ozone calibration** at the end of Sec. 9 and the live screen prompts to complete calibration.

The adjacent screen appears after selecting Ozone calibration:

```
1.234µS/cm  25.0°C
SN Calibration
Zero Cal
In Process Cal
```

### 9.8.1 Zeroing the Sensor

The following screen will appear during Zero Cal

```
1.234 nA
SN Zero Cal
Zeroing
Wait
```

The following screen will appear if In Zero Cal is successful. The screen will return to the Amperometric Cal Menu.

```
1.234 nA
SN Zero Cal
Sensor zero done
```

The following screen may appear if In Zero Cal is unsuccessful. The screen will return to the Amperometric Cal Menu.

```
1.234 nA
SN Zero Cal
Sensor zero failed

Press EXIT
```

### 9.8.2 In Process Calibration

The following screen will appear after selecting In Process Cal

```
1.234µS/cm  25.0°C
SN InProcess Cal
Wait for stable
reading.
```

If the In Process Cal is successful, the screen will return to the Cal sub-menu. The following screen may appear if In Zero Cal is unsuccessful. The screen will return to the Amperometric Cal Menu.

```
1.234µS/cm  25.0°C
SN InProcess Cal
Calibration
Error

Press EXIT
```

## 9.9 Calibrating Temperature

Most liquid analytical measurements require temperature compensation (except ORP and Redox). The 1066 performs temperature compensation automatically by applying internal temperature correction algorithms. Temperature correction can also be turned off. If temperature correction is off, the 1066 uses the manual temperature entered by the user in all temperature correction calculations.

To calibrate temperature, access the Calibration screen by pressing ENTER from the main screen, select Temperature and press ENTER.

The following calibration routine is covered:

1. Temperature with manual temperature entry

To calibrate temperature:

1. Press the MENU button
2. Select Calibrate. Press ENTER.
3. Select Temperature. Press ENTER.

The adjacent screen will appear.

1.234 $\mu$ S/cm 25.0°C SN Calibrate +025.0°C
---

The following sub-section provides you with the initial display screen that appears for temperature calibration. Use the **flow diagram for Temp calibration** at the end of Sec. 7 to complete calibration.

### 9.9.1 Calibration

The adjacent screen will appear during Temperature Cal.

If the sensor Temperature offset is greater than 5 °C from the default value, the following screen will appear:

1.234 $\mu$ S/cm 25.0°C SN Calibrate Cal in progress. Please wait.
---

You may continue by selecting Yes or suspend this operation by selecting No.

1.234 $\mu$ S/cm 25.0°C SN Temp Offset > 5°C Continue? <b>No</b> Yes
--

If the Temp Cal is successful, the screen will return to the Cal Menu.

**Note:** To select automatic or manual temp compensation or to program temperature units as °C or °F, refer to Sec. 9.3? – Programming Temperature in this manual.





Figure 9-3. Calibrate Free Chlorine, Total Chlorine, and Monochloramine

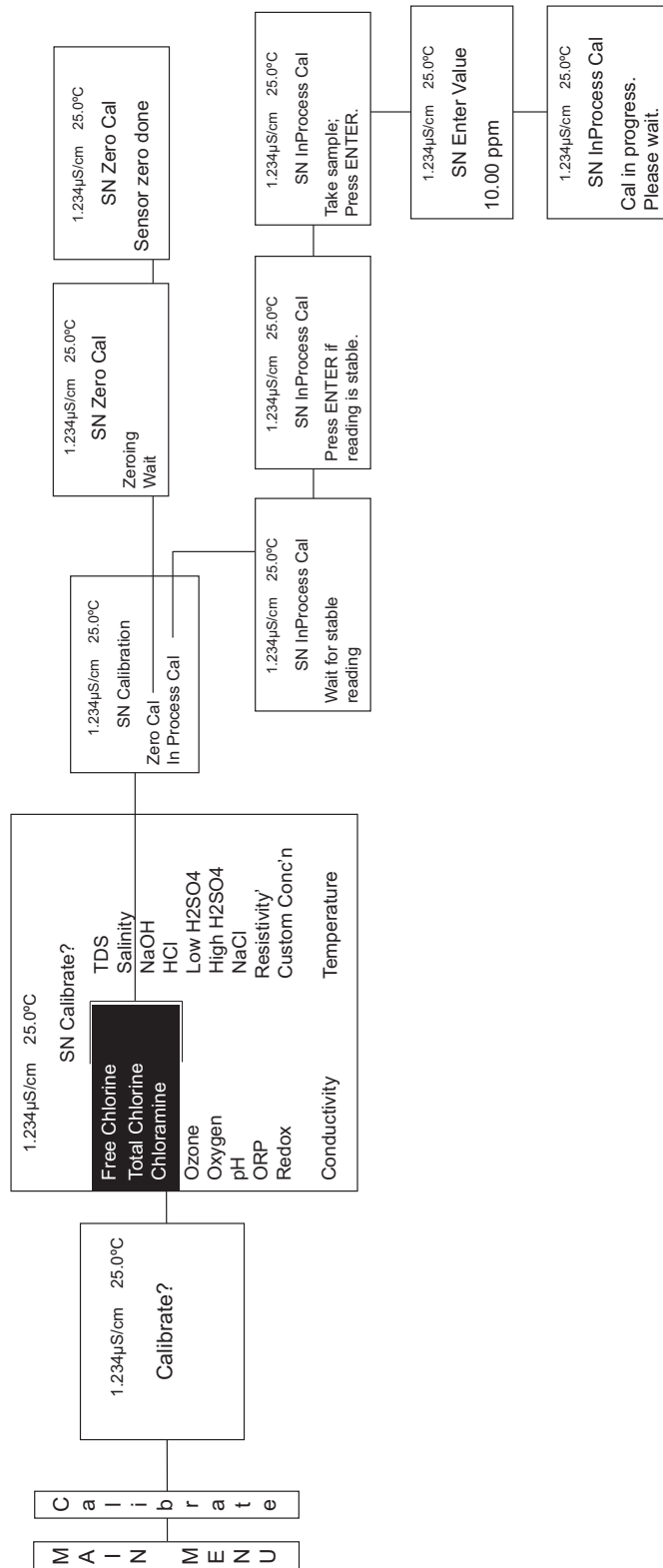

Figure 9-4. Calibrate Oxygen

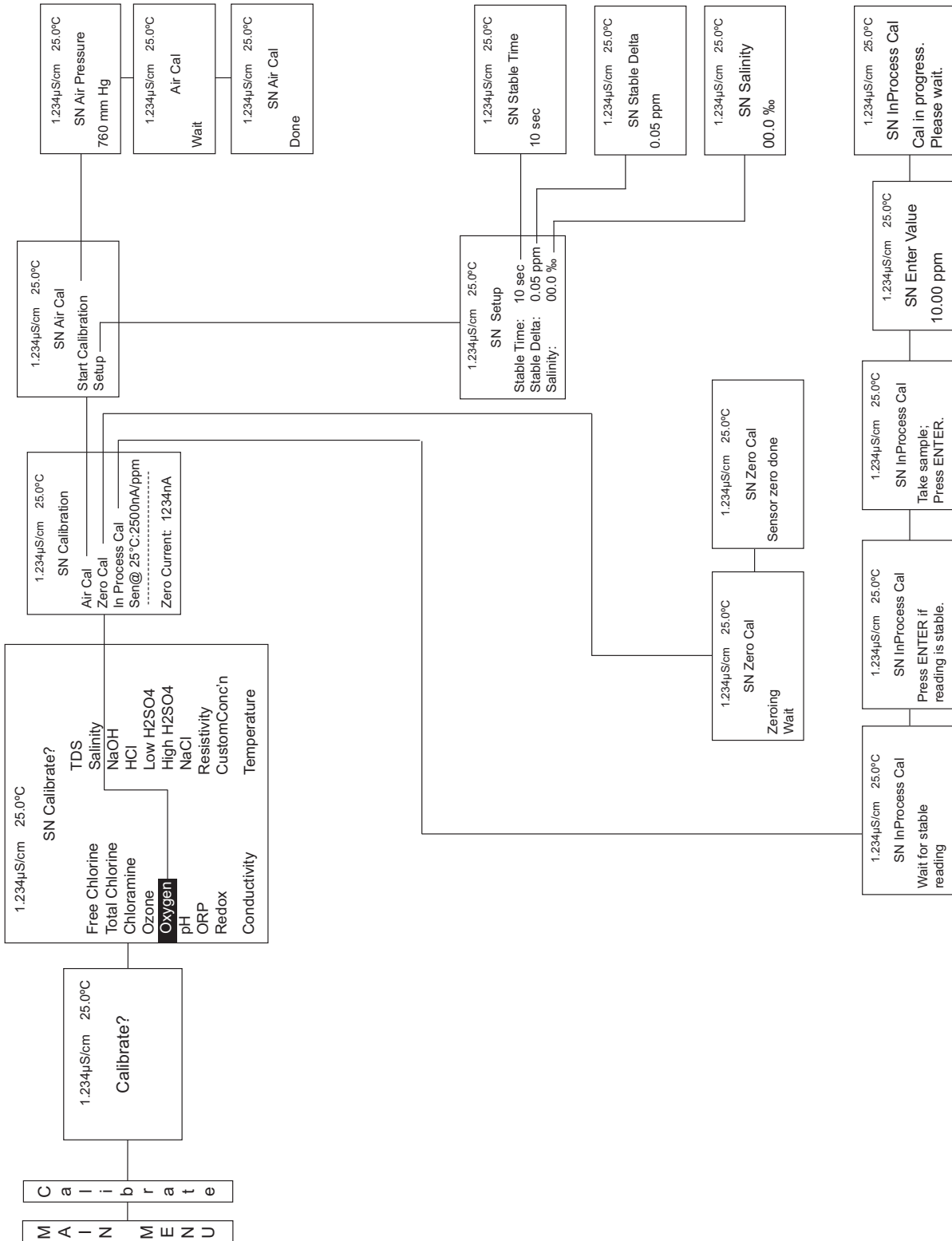

Figure 9-5. Calibrate Ozone

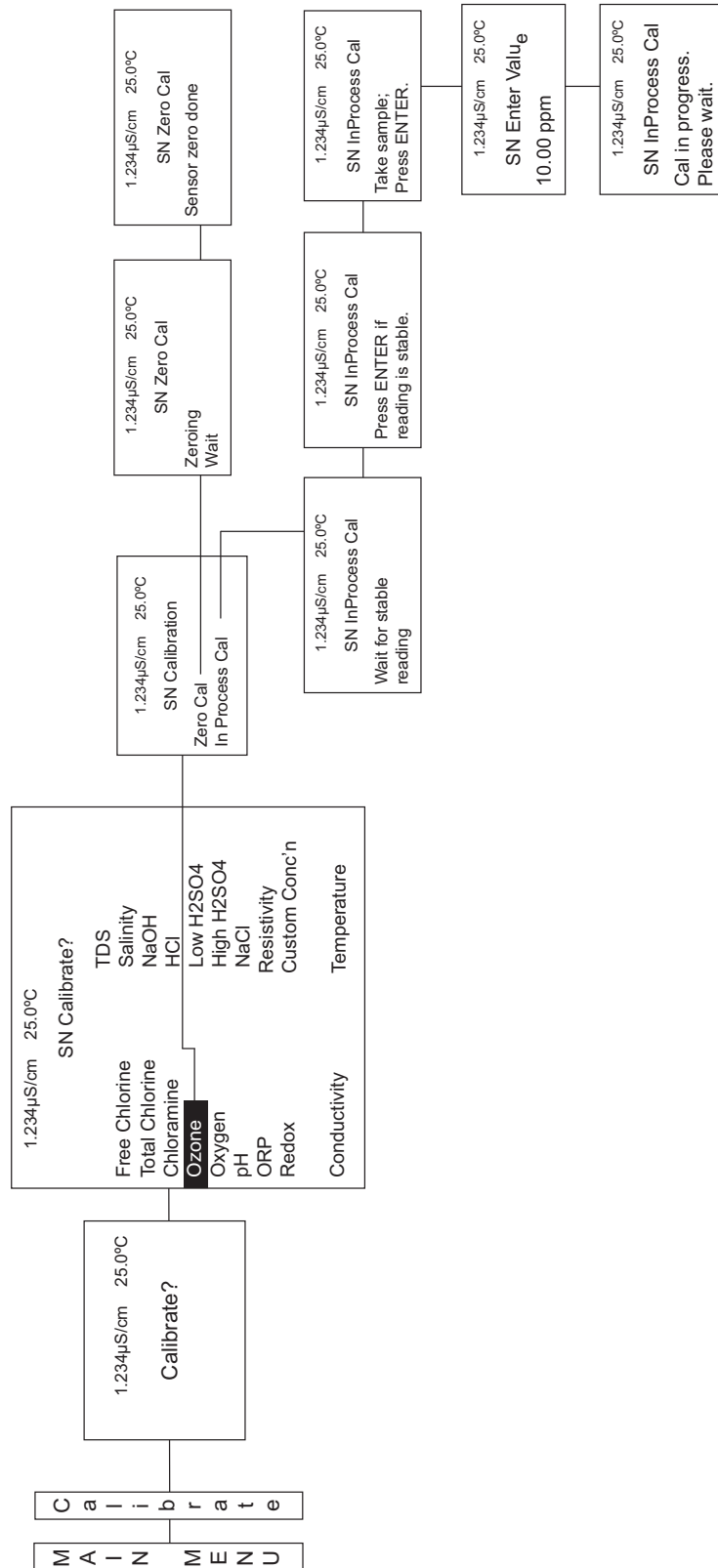

FIGURE 9-6. Calibrate ORP

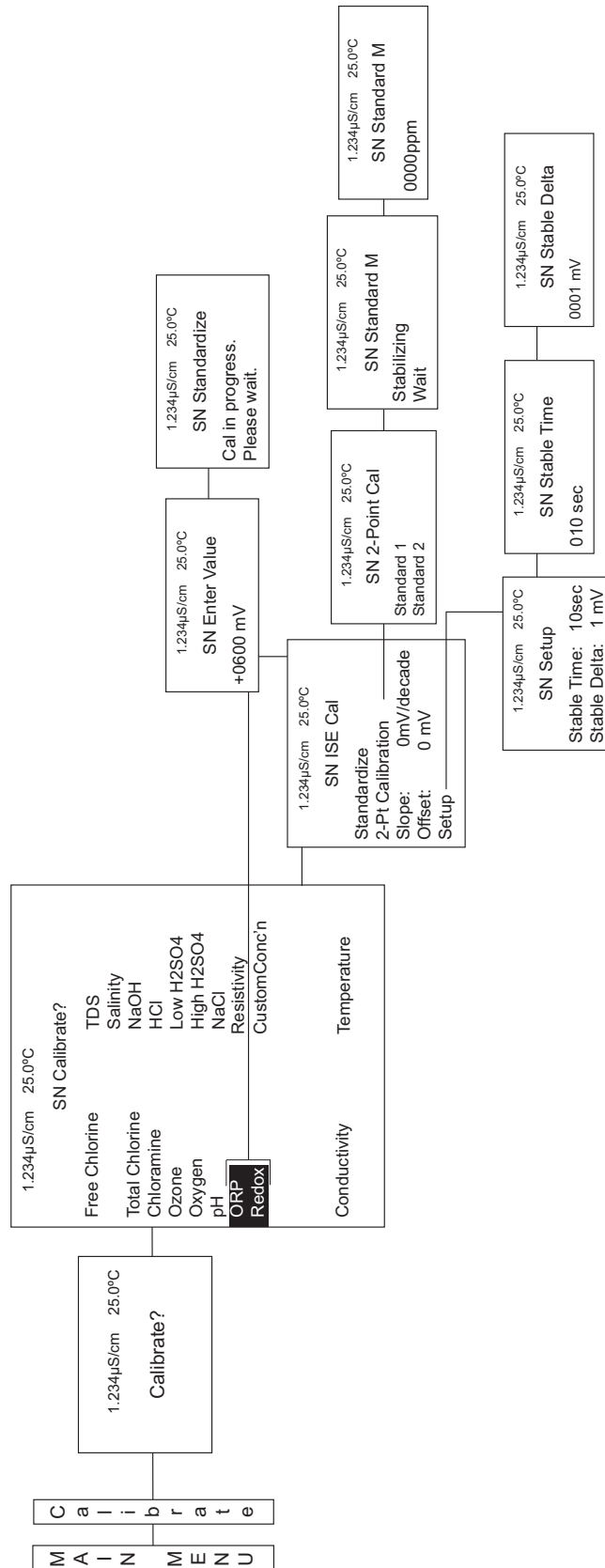
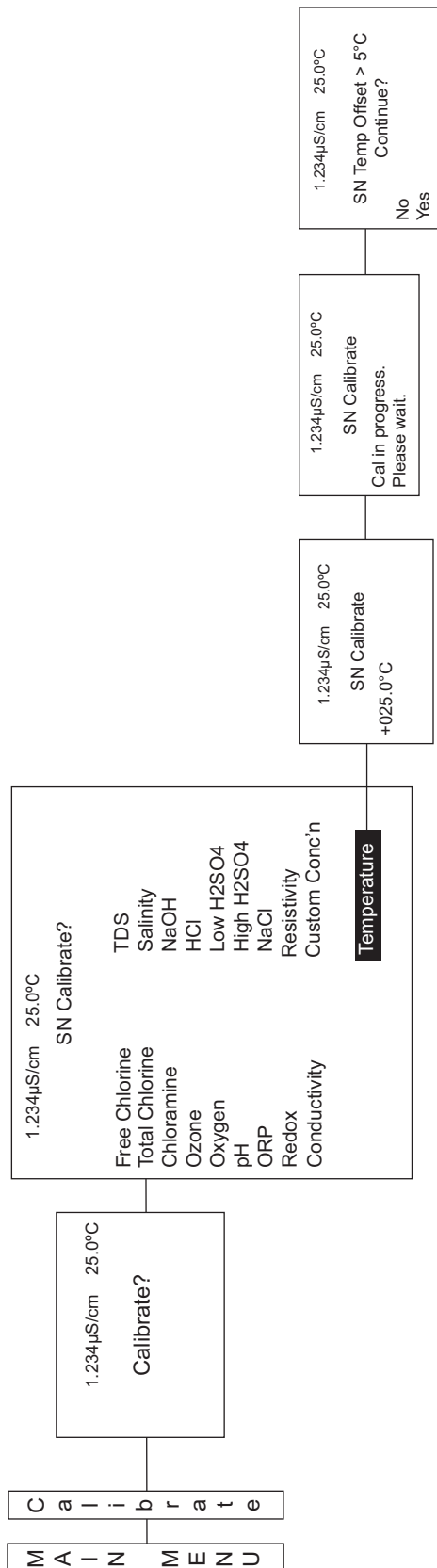

FIGURE 9-7. Calibrate Temperature



## Section 10: Return of Material

### 10.1 General

To expedite the repair and return of instruments, proper communication between the customer and the factory is important. Before returning a product for repair, call 1-949-757-8500 for a Return Materials Authorization (RMA) number.

### 10.2 Warranty Repair

The following is the procedure for returning instruments still under warranty:

1. Call Rosemount Analytical for authorization.
2. To verify warranty, supply the factory sales order number or the original purchase order number. In the case of individual parts or sub-assemblies, the serial number on the unit must be supplied.
3. Carefully package the materials and enclose your “Letter of Transmittal” (see Warranty). If possible, pack the materials in the same manner as they were received.

4. Send the package prepaid to:

Rosemount Analytical  
2400 Barranca Parkway  
Irvine, CA 92606  
Attn: Factory Repair  
RMA No. \_\_\_\_\_  
Mark the package: Returned for Repair  
Model No. \_\_\_\_\_

#### IMPORTANT

Please see second section of “Return of Materials Request” form. Compliance with the OSHA requirements is mandatory for the safety of all personnel. MSDS forms and a certification that the instruments have been disinfected or detoxified are required.



### 10.3 Non-Warranty Repair

The following is the procedure for returning for repair instruments that are no longer under warranty:

1. Call Rosemount Analytical for authorization.
2. Supply the purchase order number, and make sure to provide the name and telephone number of the individual to be contacted should additional information be needed.
3. Do Steps 3 and 4 of Section 10.2.

#### NOTE

Consult the factory for additional information regarding service or repair.

<b>ROSEMOUNT</b> Analytical	<b>EC Declaration of Conformity</b>		<b>CE</b>
<p>We, Emerson Process Management, Blegistrasse 21, Barr, Switzerland CH 6341 declare under our sole responsibility that the product,</p>			
<b>Model 1066-AA-BB-CC Smart-enabled, 2-wire Transmitter;</b>			
Where AA is:	Where BB is:	Where CC is:	
P (pH/ORP measurement)	HT (Analog/HART communication)	73 (Labeled for Atex/IECEx)	
CL (Chlorine measurement)	FF (Fieldbus communication)	69 (Labeled for CSA)	
DO (Dissolved Oxygen measurement)	FI (FISCO communication)	67 (Labeled for FM)	
OZ (Ozone measurement)		60 (Not labeled for agency)	
<p>manufactured by, Emerson Process Management, Rosemount Analytical Inc., 2400 Barranca Parkway, Irvine California 92606 USA</p> <p>to which this declaration relates, is in conformity with the provisions of the European Community Directives, including the latest amendments, as shown in the attached schedule.</p> <p>Assumption of conformity is based on the application of the harmonized standards and, when applicable or required, a European Community notified body certification, as shown in the schedule.</p>			
 (signature)		Vice President Analytical Europe (function name)	
Andy Kemish (name printed)		November 17, 2011 (date of issue)	
<b>Schedule</b>			
<hr/>			
<b>EMC Directive (2004/108/EC)</b> Harmonized standard used: EN 61326-1: 2006			
<hr/>			
<b>ATEX Directive (94/9/EC)</b> Provisions of the directive fulfilled by the equipment: Equipment Group II, Category 1 G (Ex ia IIC T4)			
<b>Intrinsically Safe Certificate: Baseefa11ATEX0195X</b> Special Condition for safe use: The plastic enclosure, excluding the front panel, may constitute a potential electrostatic ignition risk and must only be cleaned with a damp cloth.			
Harmonized standards used: 60079-0:2011 60079-11:2011			
<b>ATEX Notified Body for EC Type Examination Certificate &amp; Quality Assurance:</b> Baseefa [Notified Body Number: 1180], Rockhead Business Park, Staden Lane Buxton, Derbyshire SK17 9RZ, United Kingdom			
CE marking was first affixed to this product in 2011			
			

**ROSEMOUNT**  
Analytical



## EC Declaration of Conformity

We, **Emerson Process Management, Blegistrasse 21, Baar, Switzerland CH 6341**  
declare under our sole responsibility that the product,

**Model 1066-AA-BB-CC Smart-enabled, 2-wire Transmitter;**

Where AA is:	Where BB is:	Where CC is:
C (Contacting Conductivity measurement)	AN (Analog current outputs only)	60 (Not labeled for agency)
T (Toroidal Conductivity measurement)	HT (Analog/HART communication)	
	FF (Fieldbus communication)	
	FI (FISCO communication)	

manufactured by, **Emerson Process Management, Rosemount Analytical Inc.,  
2400 Barranca Parkway, Irvine California 92606 USA**  
to which this declaration relates, is in conformity with the provisions of the  
European Community Directives, including the latest amendments, as shown in the  
attached schedule.

Assumption of conformity is based on the application of the harmonized standards  
and, when applicable or required, a European Community notified body  
certification, as shown in the schedule.

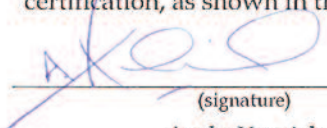
  
\_\_\_\_\_  
(signature)  
**Andy Kemish**  
(name printed)

Vice President Analytical Europe  
(function name)  
March 13, 2012  
(date of issue)

### Schedule

**EMC Directive (2004/108/EC)**  
Harmonized standard used: EN 61326-1: 2006

CE marking was first affixed to this product in 2012







*The right people,  
the right answers,  
right now.*

**ROSEMOUNT ANALYTICAL  
CUSTOMER SUPPORT CENTER  
1-800-854-8257**



ON-LINE ORDERING NOW AVAILABLE ON OUR WEB SITE  
[rosemountanalytical.com](http://rosemountanalytical.com)

*Specifications subject to change without notice.*

Credit Cards for U.S. Purchases Only.



### Emerson Process Management

2400 Barranca Parkway  
Irvine, CA 92606 USA  
Tel: (949) 757-8500  
Fax: (949) 474-7250

[rosemountanalytical.com](http://rosemountanalytical.com)

© Rosemount Analytical Inc. 2012

