



# OPERATING MANUAL

For  
MSSD53  
Suspended Solids  
and  
Turbidity Transmitter

Software Version 1.6



# IMPORTANT NOTICE

Please read this first before installation.

**S** series sensors  
(suspended solids)

**T** series sensors  
(turbidity )

Dependent upon which sensor you have ordered the correct signal conditioning board has been installed in this transmitter.

Inside the transmitter terminal cover is a label that identifies which sensor is to be used with this instrument. Please check this label before connecting the sensor.



## QUICK START-UP GUIDE FOR THE MSSD 53

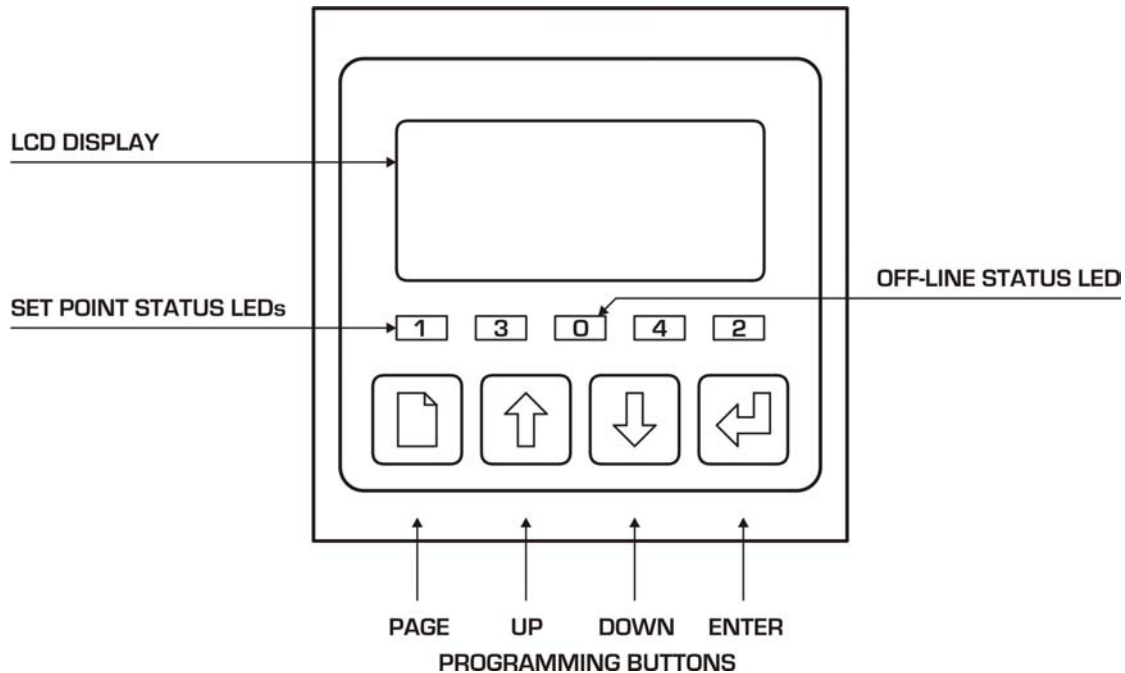

### Keypad layout

The front panel of the MSSD53 has a membrane keypad with 4 keys, each with its own symbol. The user interface to the MSSD53 is arranged as a menu structure, a summary of which is printed at the back of this manual and should be used in conjunction with this easy start-up guide. Movement around this menu structure is achieved using the “PAGE”, “UP”, “DOWN” and “ENTER” keys at the bottom of the front panel. To guide you through the configuration the symbols are also shown on the menu structure summary.

- The sensor, supply and other external wiring should be connected as per terminal connections layout on page 5.
- Before powering up the instrument, check that the supply voltage is the same as the instrument specification.
- When the power is applied, the display should indicate some measurement value between 0 and 100. The MSSD53 has default parameters entered into its configuration, which are listed on page 36 of this instruction manual. The default measurement range is 0 to 100%.

The configuration/calibration procedure for the MSSD53 is a simple sequence of operations listed below.

1. It is suggested that you temporarily remove the access code protection during this procedure and replace it again after completion. Refer to page 14 to change the “level two” access code from the default value of 0002 to 0000. When the access code is changed to 0000 the instrument no longer has any protection from unauthorized interference.
2. When the access code is changed and the key symbol appears, press the “page” key again which takes you to the **“Operating Mode”** page.
3. The **“Operating Mode”** default is “On-Line”. If at this stage the current output and relays are already connected then change from “On-Line” to “Off-Line” mode using the up/down and enter keys, this is to avoid making any process disturbances while adjusting the setting of the instrument. Refer page 15 for full details.

4. Press the page key to enter the **"Parameters"** page. This sets the display units and the range of the instrument. The default units are "%" and the range is 0 to 100. Refer to page 16 for full details.
5. Press the page key to enter the **"Set Points 1 & 2"** page which allows you to configure the relay outputs. The default settings for both relays are "disabled". Refer to page 18 for full details.
6. Press the page key to enter the **"Current Output"** page. The default values are 4-20mA and 0 to 100% (the same as the range). Refer to page 22 for full details.
7. Enter the **"Linearization"** by pressing the page key to alter the linearization from the default 2-point curve. Refer to page 24 for full details.
8. Pressing the page key again will bring up the **"Optimisation"** page. This allows you to make adjustments "On-Line" after the sensor has been installed in the process. At this stage there are no adjustments to be made to these settings. Refer to page 26 for full details.
9. Pressing the page key gives you access to the **"Save / Restore"** page. Unless you require to return to the factory default values, there is no adjustment to be made to these parameters at this point. Refer to page 28 for full details.
10. Pressing the page key again will bring you to the **"Configuration"** page. The default values are "Language: English", "Error Messages: Enabled", and "Input Filter: OFF". Enter the configuration menu to change the input filter time constant or to turn OFF the error messages. Refer to page 30 for full details.
11. Once you have completed the configuration go back to the **"Operating Mode"** page and check that the instrument is "On-Line" and then go to the **"Save / Restore"** page and save your configuration as set-up A or B.
12. The final operation is to restore the access codes to eliminate unauthorized interference with the settings of this instrument.

## PREFACE

### Product warranty

The MSSD53 suspended solids transmitter has a warranty against defects in materials and workmanship for two years from the date of shipment. During this period BARBEN ANALYZER TECHNOLOGY, LLC will, at its own discretion, either repair or replace products that prove to be defective. The associated software is provided 'As is' without warranty. Sensor warranty is 12 months from date of shipment.

### Limitation of warranty

The foregoing warranty does not cover damage caused by accidental misuse, abuse, neglect, misapplication or modification.

No warranty of fitness for a particular purpose is offered. The user assumes the entire risk of using the product. Any liability of Barben Analyzer Technology, LLC is limited exclusively to the replacement of defective materials or workmanship.

There are no user serviceable parts, including fuses etc. within the unit. Any attempt to dismantle the instrument will invalidate the warranty.

### Disclaimer

As part of our policy of continual development and improvements Barben Analyzer Technology, LLC reserves the right to make changes to this manual or the instrument without notice.

All care has been taken to ensure accuracy of information contained in this manual. However, we cannot accept responsibility for any errors or damages resulting from errors or inaccuracies of information herein.

## Manufacturing Standards

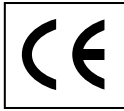

### **Electromagnetic compatibility**

This instrument has been designed to comply with the standards and regulations set down by the European EMC Directive

### **Safety**

This instrument has been designed to comply with the standards and regulations set down by the European Low Voltage Directive using BS EN 61010-1: 1993

### **Quality**

This instrument has been manufactured under the following quality standard:

BS EN ISO 9002:1994 (BS 5750 part 2-1987). Certificate No: FM 13843

Note: The standards referred to in the design and construction of Barben Analyzer Technology, LLC products are those prevailing at the time of product launch. As the standards are altered from time to time, we reserve the right to include design modifications that are deemed necessary to comply with the new or revised regulations.

# CONTENTS

QUICK START-UP GUIDE FOR THE MSSD 53 .....	I
PREFACE.....	III
CONTENTS.....	V
INTRODUCTION .....	1
About the MSSD53 .....	1
Unit Specification .....	1
INSTALLATION .....	3
Wiring Installation .....	3
Noise Suppression .....	3
Mounting .....	4
Pipe Mounting .....	5
Terminal Connections .....	5
Supply Voltage Connections .....	6
Current Output Connections .....	6
Relay Connections .....	6
Sensor Input Connections .....	7
Digital Inputs .....	7
USER INTERFACE .....	9
The Front Panel .....	9
The Menu System .....	9
Error Messages.....	9
Access Entry .....	10
Unit Configuration .....	12
MAIN DISPLAY .....	13
ACCESS CODE .....	14
OPERATING MODE .....	15
On-Line / Off-Line Operation .....	15
PARAMETERS.....	16
Display Units .....	16
Range .....	16
Simulated Input.....	16
SET POINTS 1 & 2.....	18
Set Point Source .....	19
Set Point Trigger .....	19
Dose Alarm Timers .....	19
Sensor Cleaning.....	20
CURRENT OUTPUT .....	22
Input .....	22
Output Range.....	22
Zero & Span .....	23
Proportional Control .....	23
Error Condition .....	23
LINEARIZATION .....	24
OPTIMISATION.....	26

---

SAVE / RESTORE .....	28
CONFIGURATION .....	30
FAULT FINDING .....	31
The Instrument Appears Dead .....	31
The Access Code Does Not Work.....	31
The Sensor Reading Is Constantly Over-range or Under-range .....	31
The Sensor Reading is Incorrect.....	31
Current Output is Incorrect or Noisy.....	31
Relays Appear to Malfunction .....	32
A Bell Symbol is Flashing on the Display .....	32
GUARANTEE AND SERVICE.....	33
APPENDIX A – SUSPENDED SOLIDS .....	35
Suspended Solid Measurement .....	35
Principles of the Barben Sensor.....	35
Linearization Data .....	35
APPENDIX B – FACTORY DEFAULT SET-UP.....	36
APPENDIX C – CUSTOMER SET-UP.....	38
APPENDIX D – CALIBRATION / OPTIMISATION.....	40
Calibration / Optimisation Procedures.....	40
Zero Offset Adjustment .....	40
Span Offset Adjustment .....	40
APPENDIX E – ERROR MESSAGES .....	42
INDEX.....	44

# INTRODUCTION

## ABOUT THE MSSD53

The MSSD53 is a microprocessor controlled suspended solids measurement instrument. The unit utilises a multifunction LCD to display readings and provide feedback to the operator. It is available with different options to provide fully configurable control, alarm and feedback with two relays and one 0/4-20mA current output source.

## UNIT SPECIFICATION

<b>Sensor Type</b>	Barben
<b>Sensor Input</b>	Proportional probe signal from 0 to 16000.
<b>Linearization</b>	The incoming probe signal can be converted to standard engineering units using up to a five-point linearization.
<b>Sensor Cable Length</b>	Up to 100 metres.
<b>Display Units</b>	User selectable from: %, NTU, FTU, mg/l, g/l, ppm, ppt, OD, EBC. In ranges of 0 – 9.999, 99.99, 999.9 and 9999. (Except % which is 0 - 10.00% and 0 – 100.0%).
<b>Repeatability</b>	±10 Probe input signal
<b>Ambient Operating Temperature</b>	-20°C to +50°C (-4°F to +122°F) for full specification.
<b>Ambient Temperature Variation</b>	±0.01% of range / °C (typical).
<b>User Interface</b>	Large 4 character 7-segment display for measured value, with alphanumeric dot matrix characters for units, information display and programming. Easy to use four-button user interface for instrument programming.
<b>Current output</b>	Selectable 0-20mA or 4-20mA operation into a 1000Ω maximum load, fully isolated to 2kV. Selectable transmission of either sensor reading or temperature, and software scalable within the operating range.
<b>Operator adjustment (Current)</b>	±1mA zero and ±1mA span for remote monitor calibration.
<b>Set Point Relays</b>	Two fully configurable set point relays with volt free contacts. Rated at 5A 30V DC / 5A 250VAC (non-inductive).
<b>Operating Modes</b>	Configurable High, Low, Band or Latch trigger conditions, selectable for each relay. Adjustable hysteresis and delay timers of up to 10 minutes. Adjustable dose alarm timer up to 15 minutes. Adjustable duration, recovery and interval periods in the “Cleaning” mode. The relays can also be set to energise on any one of the following instrument conditions: Sensor error. Transmitter error messages.
<b>Off-Line Facility (for calibration and commissioning)</b>	Initiated by remote contact closure or software selection. The relays are de-energised and the current outputs are held at the last On-Line value.
<b>EMC: Immunity</b>	BS EN 50082-2 1995.
<b>EMC: Emissions</b>	BS EN 50081-1 1992.

<b>Safety</b>	Designed and manufactured in accordance with BS EN 61010-1 1993.
<b>Power Supply</b>	85 to 250V AC or DC 10W max.
<b>Optional</b>	18 to 36V AC or DC 15 W max
<b>Housing</b>	Expanded polyurethane foam rated to IP66
<b>Weight</b>	Less than 1.5kg
<b>Dimensions</b>	305mm x 200mm x 82mm (H x W x D), excluding mounting brackets

## INSTALLATION

This chapter describes how to install and mount the MSSD53, and how to connect the unit to a power source and auxiliary equipment.

Although today's electronic components are very reliable, it should be anticipated in any system design that a component could fail and it is therefore desirable to make sure a system will **fail-safe**. This could include the provision of an additional monitoring device, depending upon the particular application and any consequences of an instrument or sensor failure.

### WIRING INSTALLATION

The specified performance of the MSSD53 is entirely dependent on correct installation. For this reason, the installer should thoroughly read the following instructions before attempting to make any electrical connections to the unit.

**CAUTION ! : ALWAYS REMOVE THE MAIN POWER FROM THE SYSTEM BEFORE ATTEMPTING ANY ALTERATIONS TO THE WIRING. ENSURE THAT BOTH POWER INPUT LINES ARE ISOLATED. MAKE SURE THAT THE POWER CANNOT BE SWITCHED ON BY ACCIDENT WHILST THE UNIT IS BEING CONNECTED. FOR SAFETY REASONS AN EARTH CONNECTION MUST BE MADE TO THE EARTH TERMINAL OF THIS INSTRUMENT.**

**LOCAL WIRING AND SAFETY REGULATIONS SHOULD BE STRICTLY ADHERED TO WHEN INSTALLING THIS UNIT. SHOULD THESE REGULATIONS CONFLICT WITH THE FOLLOWING INSTRUCTIONS, CONTACT BARBEN ANALYZER TECHNOLOGY, LLC OR YOUR LOCAL DISTRIBUTOR FOR ADVICE.**

To maintain the specified levels of Electro Magnetic Compatibility (EMC, susceptibility to and emission of electrical noise, transients and radio frequency signals) it is essential that the types of cables recommended within these instructions be used. If the installation instructions are followed carefully and precisely, the instrument will achieve and maintain the levels of EMC protection stated in the specification. Any equipment to which this unit is connected must also have the same or similar EMC control to prevent undue interference to the system.

- ◆ Terminations at the connectors should have any excess wire cut back so that a minimal amount of wire is left free to radiate electrical noise inside or close to the instrument housing.
- ◆ The terminal cover of the surface mount unit must be correctly re-assembled and securely fastened, to maintain a continuous electro-magnetic shield around the instrument.

N.B. The use of CE marked equipment to build a system does not necessarily mean that the completed system will comply with the European requirements for EMC.

### NOISE SUPPRESSION

In common with other electronic circuitry, the MSSD53 may be affected by high level, short duration noise spikes arising from electromagnetic interference (EMI) or radio frequency interference (RFI).

The following noise generating sources can affect the MSSD53 through capacitive or inductive coupling.

- ◆ Relay coils.
- ◆ Solenoids.
- ◆ AC power wires, particularly at or above 100VAC.
- ◆ Current carrying cables.
- ◆ Thyristor field exciters.
- ◆ Radio frequency transmissions.
- ◆ Contactors.
- ◆ Motor starters.
- ◆ Business and industrial machines.
- ◆ Power tools.
- ◆ High intensity discharge lights.
- ◆ Silicon control rectifiers that are phase angle fired.

The MSSD53 is designed with a high degree of built in noise rejection, to minimise the potential for interference. However, it is recommended that you apply the following wiring practices as an added precaution. Cables transmitting low-level signal should not be routed near contactors, motors, generators, radio transmitters, or wires carrying large currents.

If noise sources are so severe that the instrument's operation is impaired, or even halted, the following external modifications should be made, as appropriate:

- Fit arc suppressers across active relay or contactor contacts in the vicinity.
- Run signal cables inside steel tubing as much as is practical.
- Use the internal relays to switch external slave relays or contactors when switching heavy or reactive loads.
- Fit an in-line mains filter close to the power terminals of the instrument.
- In cases of very high background RF and HF noise environments, Barben Analyzer Technology, LLC can supply a length of proprietary RF suppressing mains cable.

### MOUNTING

The unit is designed for fixing to a wall or other flat surface. Three 6.5 mm diameter holes are provided for this purpose. Note that fasteners are not provided.

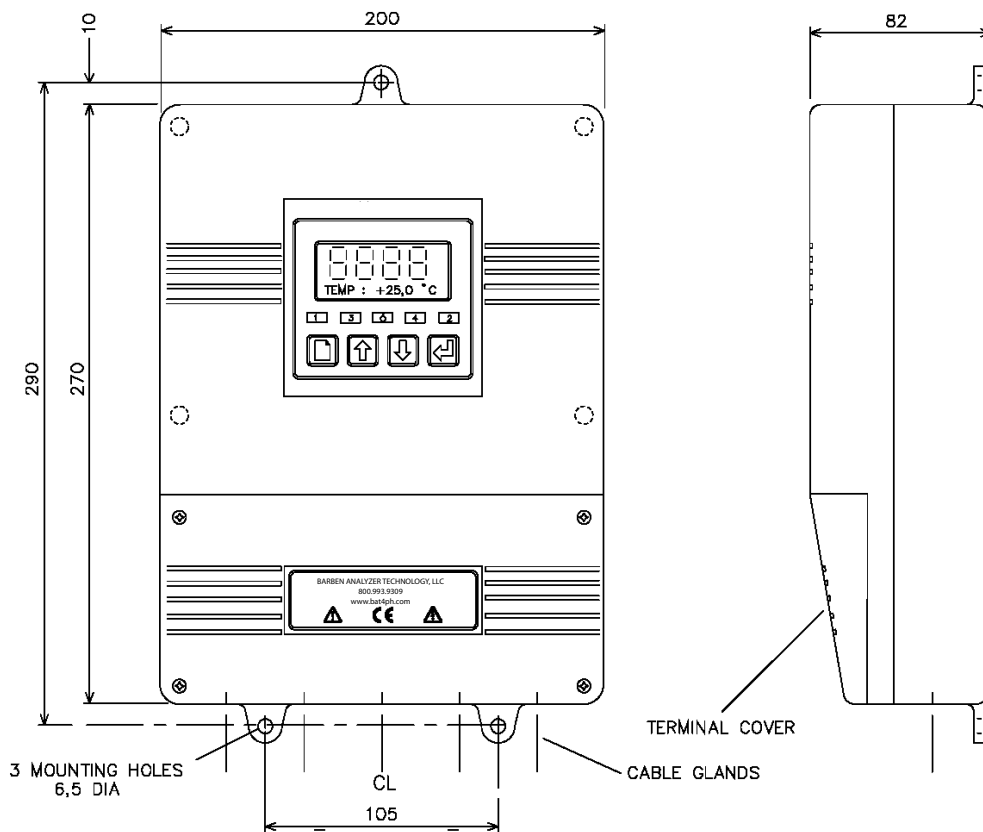

**Figure 1 : Overall dimensions MSSD53.**

Barben Analyzer Technology, LLC recommend using No. 10 x 1¼ inch round head screws or similar for mounting.

Care must be taken when fitting the unit to uneven walls or surfaces. Do not over stress the three mounting lugs.

Over tightening the mounting screws could also break the lugs.

## PIPE MOUNTING

The handrail & pipe mounting option is designed for fixing to a vertical or horizontal handrail or pipe, of 25 - 60 mm outside diameter. The mounting kit comprises 1 x plate, 2 x channels, 2 x clamps, 4 x studs, 3 x M5 nuts, 3 x M5 plain washers, 3 x M5 shake proof washers, 12 x M4 nuts and 12 x M4 shake proof washers, as shown in the exploded view below.

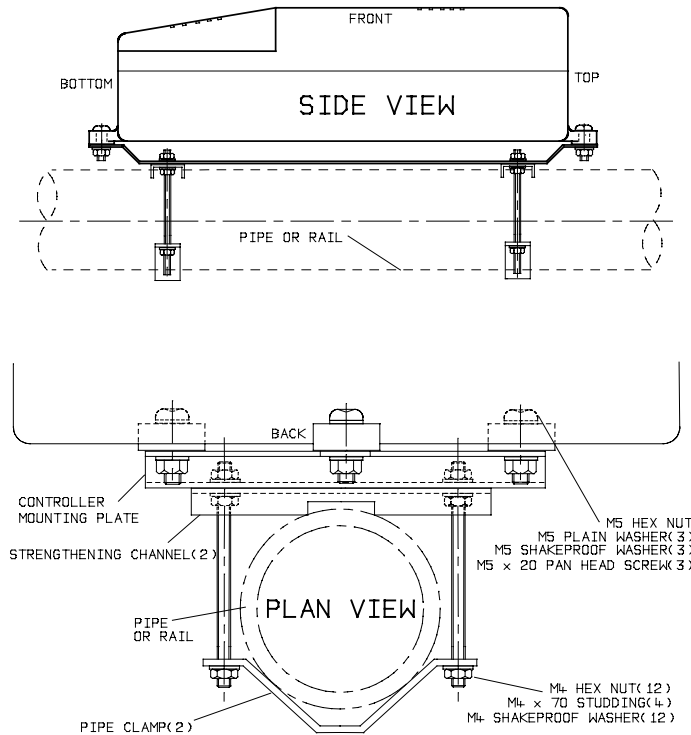
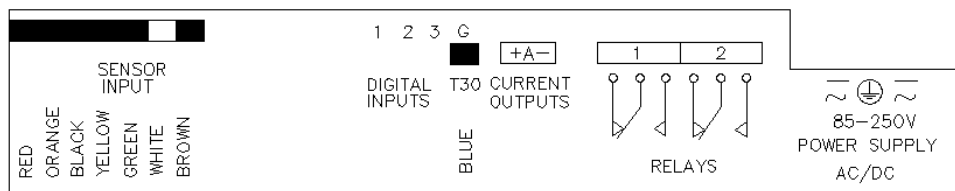

**Figure 2: MSSD53 handrail & pipe mounting brackets.**

- ◆ The brackets can be fitted either vertically or horizontally.
- ◆ Position the channels to the rear of the mounting plate and secure with 8 x M4 nuts and 8 x M4 shake proof washers as shown.
- ◆ Position the mounting plate assembly onto the pipe/handrail ensuring that the single fixing hole for the controller is at the top.
- ◆ Secure the two pipe clamps with the 4 x M4 nuts and 4 x M4 shake proof washers.
- ◆ Attach the controller to the mounting plate with the 3 sets of M5 fixings supplied.

## TERMINAL CONNECTIONS

Having ensured that the main power is isolated from the unit, remove the terminal cover by releasing the screws at each corner; the terminal cover is the small cover at the bottom of the front panel (see Figure 1, page 4). Once the cover has been removed, the following terminal arrangement should be visible. Some terminals may not be fitted due to different supplied options.



**Figure 3: MSSD53 Terminal connections.**

The cables should be fed through the cable glands. After each cable has been attached, pull most of the cable slack back through the cable gland to prevent any unwanted RF energy from being radiated inside the housing. Make sure not to strain the cable within the instrument. Tighten the cable gland onto the

cable so that it grips sufficiently to seal and to prevent the cable from being pulled back through the gland.

### SUPPLY VOLTAGE CONNECTIONS

The MSSD53 can be powered from either an AC or DC supply voltage. The unit provides two terminals for each of the input connections (“Live” & “Neutral” for an AC input, or + & - for a DC Input), plus an “Earth” terminal. This allows the supply to be “daisy chained” to the relay contacts and/or other instruments. The instrument uses a universal power supply that accepts a wide range of voltage and frequency inputs. **Refer to the label adjacent to the power supply terminals for the input voltage limits. Exceeding these limits may damage the instrument.**

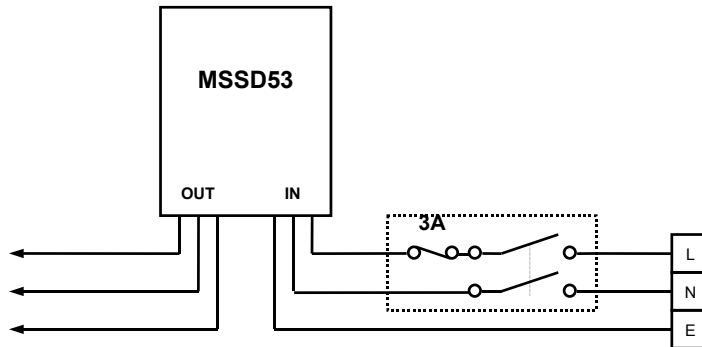

Figure 4: Power supply “daisy chain” connection.

The power supply should be taken from an isolated spur and fused to a maximum of 3 Amps. If the relays require greater current, then a separate 5A fuse will be required. **The incoming Earth connection must be connected to the “Earth” terminal.**

### CURRENT OUTPUT CONNECTIONS

The MSSD53 can be supplied with a current output designated “A”. The unit is shipped with a link across the relevant current output pins if the option is fitted. If a current output is required, remove this link and replace it with a cable terminated by a load resistance not exceeding 1000Ω. For best noise immunity use a screened twisted pair cable, with the screen connected to Earth at one end. Use a sufficiently large cable to avoid a high resistance in the overall current loop.

### RELAY CONNECTIONS

The relay contacts are connected to the terminals only and are electrically isolated from the instrument itself. **They must be connected in series with a 5 Amp fuse.**

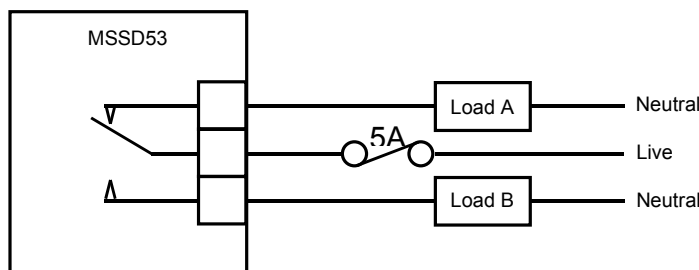
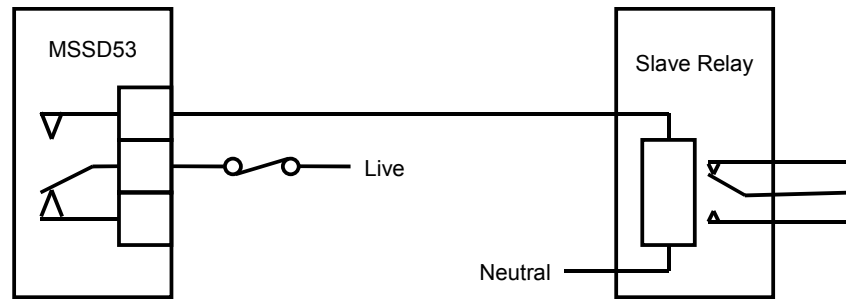

Figure 5: Relay contact connection.

A contact arc suppresser may be required to prevent excessive electrical noise, depending upon the load. To switch more than 5 Amps will require a slave relay.



**Figure 6: Slave relay connection.**

For convenience, the power can be looped across from the supply connections.

## SENSOR INPUT CONNECTIONS

The MSSD53 has been designed with the flexibility to accept a variety suspended solids probes (consult Barben Analyzer Technology, LLC about compatibility of third party sensors). The terminal connections are colour coded to provide simple and clear indications of the wiring positions.

The outer screen/shield (clear plastic sheath) should be connected to the “Earth” stud provided.

## DIGITAL INPUTS

The digital inputs are used to externally initiate instrument functions. These inputs are intended to be switched using a volt free link, switch or relay. Closing the contact will initiate the appropriate action.

The CIP input indicates to the unit that a CIP event is in progress so that the sensor can be disabled to prevent overstressing the probe. When this input is closed an appropriate message (“**CIP Active**”) will appear on the main display and the probe signal will go to 0000. This will affect the Set Points and Current Outputs, so the Off-Line input should also be closed by the same input, i.e. the CIP signal should also go to the Off-Line input. The Off-Line input will disable the Set Point Relays and freeze the Current Outputs at their last value. When the Off-Line input is released the Set Point Relays will return to normal operation. The CLEAN input will initiate a clean cycle if any of the Set Points are set for “**Cleaning**” operation.

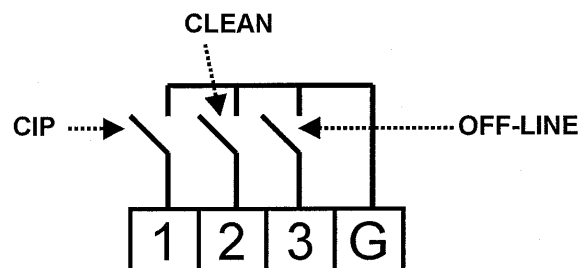

**Figure 7: Digital Inputs**

This page intentionally blank

## USER INTERFACE

**CAUTION!** BEFORE PROCEEDING, ENSURE THAT THE INSTALLATION INSTRUCTIONS HAVE BEEN FOLLOWED CORRECTLY. FAILURE TO DO SO MAY RESULT IN AN ELECTRICALLY HAZARDOUS INSTALLATION, OR DEGRADE INSTRUMENT PERFORMANCE.

When shipped the MSSD53 is configured to the default set-up (see page 36). In this state, the instrument can perform all of the necessary functions for a basic suspended solids monitoring instrument.

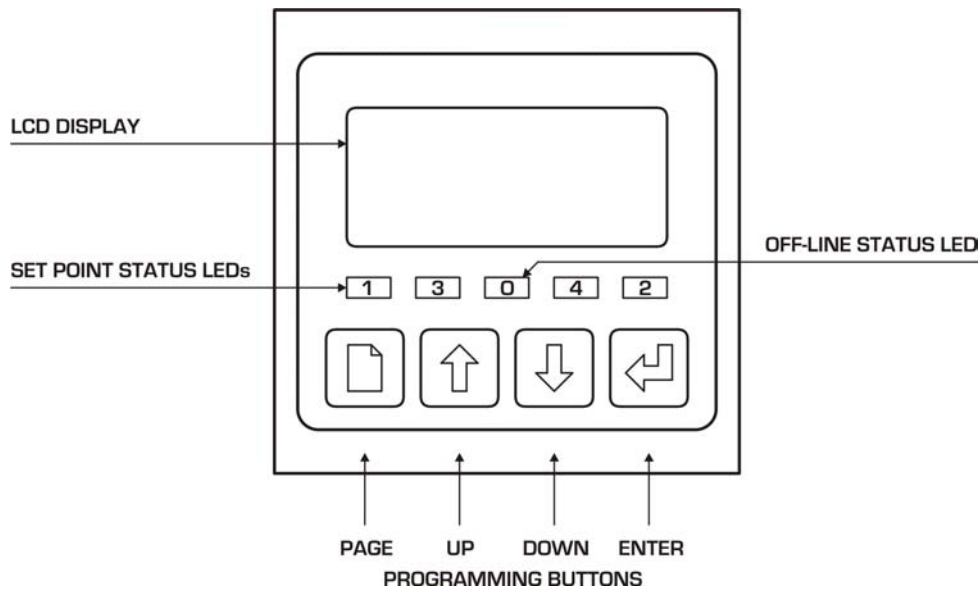

**Figure 8: User Interface Panel**

## THE FRONT PANEL

The MSSD53 uses a versatile dot matrix character LCD to display all of the settings and readings. The seven segment digits at the top of the display indicate the primary measured value during normal operation. The six-character display to the right of these indicates the units of measurement when a value is being displayed. The sixteen characters on the bottom of the display are used to indicate secondary readings or states, and to display scrolling error messages.

Along with the LCD display, the front panel also incorporates five LEDs. The four outer LEDs labelled 1, 2, 3 & 4, (3 and 4 are not installed) indicate the set point status, i.e. when the LED is illuminated the indicated relay is active. The centre LED indicates when the unit is "Off-Line".

## THE MENU SYSTEM

When the instrument is switched on, it will default to the main display menu. The user interface to the MSSD53 is arranged as a menu structure, a summary of which is printed at the back of this manual. Movement around this menu structure is achieved using the "PAGE", "UP" and "DOWN" keys at the bottom of the front panel. The functions within each menu are explained in detail in the following sections of this manual.

## ERROR MESSAGES

If the internal diagnostics have detected an error condition, the appropriate error message will flash on the bottom row of the display. A reference to these error messages can be found on page 42. Pressing the "ENTER" key when an error message is flashing will scroll a more detailed description of the error along the bottom line. Pressing "ENTER" again will return the unit to the flashing display. The error messages can be disabled within the "**Configuration**" menu (see page 30). If the error messages are disabled, the display will flash a bell symbol on the far right of the bottom row when an error is detected. It is possible to configure either relay as an error relay to provide external indication of an error conditions.

## ACCESS ENTRY

To protect the instrument set-up from unauthorised or accidental tampering, an access code must be entered. The “**Access Code**” menu will appear when the “PAGE” key is first pressed from the main display menu. A character on the upper right of the display will indicate whether access is permitted. The character will be a key for permitted access and a padlock for denied access. By default the access code will appear as 0000, however to unlock the instrument the correct code will need to be entered.

Enter the access code as follows. {Note: “*Outlined*” text represents flashing digits/characters on the display.}



Press “ENTER” to begin editing the access code.

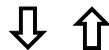

Use the “UP” and “DOWN” keys to change the first digit.



Press “ENTER” to select the next digit

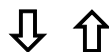

Use the “UP” and “DOWN” keys to change the second digit.



Press “ENTER” to select the next digit.

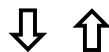

Use the “UP” and “DOWN” keys to change the third digit.

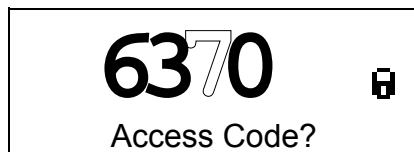

Press “ENTER” to select the next digit.

Continued on next page .....

6370  
Access Code?

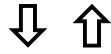

Use the "UP" and "DOWN" keys to change the last digit.

6375  
Access Code?



Press "ENTER" to store the new code.

6375  
Access Code?

If the new code is correct the Padlock symbol will now change to a Key symbol.

{Note 6375 is only an example of an access code, the correct code will need to be entered to unlock the instrument.}

### The default access codes are 0001 for level one and 0002 for level 2.

When the Key symbol is displayed the operator may then move through the menu structure using the "PAGE", "UP" and "DOWN" keys. Pressing the "PAGE" key will advance the unit on to the next menu header, using the "UP" and "DOWN" keys the operator can then select the items within that menu.

Pressing the "PAGE" key from within a menu will return the unit to the menu's header, subsequent presses of the "PAGE" key will advance to the next menu header.

When the last menu is reached the unit will return to the normal display mode. Pressing the "PAGE" and "ENTER" keys simultaneously will allow the unit to move backwards through the menus.

**N.B. When in the menu structure, if none of the buttons are pressed within 2 minutes, the unit will timeout and return to the main display. The Access Code display will be reset to 0000 30 seconds after returning to the main display.**

There are two levels of access to the menu structure (refer to the menu structure printed at the back of this manual). The first level allows access to the basic set-up operations. The more complex level 2 menus will only appear when the level 2 access code has been entered. Once the access code has been entered correctly the operator can use the "UP" and "DOWN" keys to select and modify the access codes.

0000  
Access Code?

Access Code Entry.

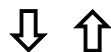

0001  
Edit Level 1

Level 1 Code Edit. Press "ENTER" to edit.  
(Available when level 1 code has been entered)

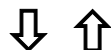

0002  
Edit Level 2

Level 2 Code Edit. Press "ENTER" to edit.  
(Available when level 2 code has been entered)

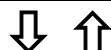

## UNIT CONFIGURATION

Editing of discrete values (such as Set Point Level) is performed in the same way as described previously for the access code entry. Changing states (such as Units or Set Point Mode) is also achieved in a similar fashion.

E.g. using the “**Display Units**” menu function (in the “**Parameters**” menu). Press the “ENTER” key to start the text flashing. Press the “UP” and “DOWN” keys to cycle through the available options, then press “ENTER” to select the required state.

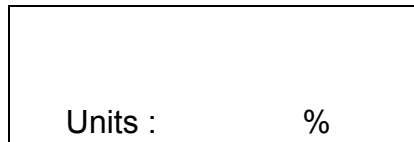

Press “ENTER” to start the units flashing.

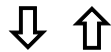
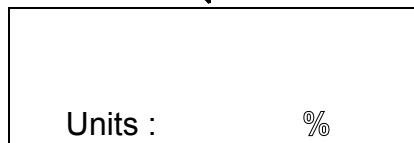

Use the “UP” and “DOWN” keys to cycle through the flashing options.

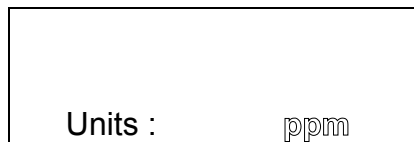

Press “ENTER” to select the flashing option.

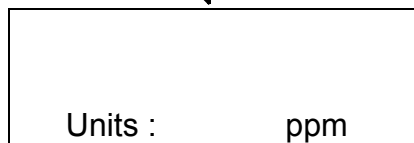

For functions such as “**Calibration**” and “**Restore Set-up**”, press the “ENTER” key to initiate the function, the system will then ask for confirmation. Press “ENTER” to continue or “UP” or “DOWN” to cancel the function. e.g.



Select the required function and press the “ENTER” key

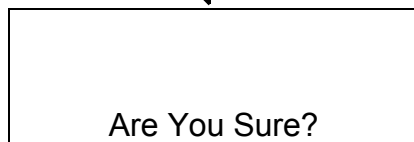

To continue press the “ENTER” key again  
To abort the “Restore”, press any other key



When the set-up has been restored, the system will return to the main display.



The following sections of this guide describe in more detail each of the menus and their functions.

## MAIN DISPLAY

The normal mode of operation is to display the sensor reading on the top row and the secondary reading on the bottom row. Using the “UP” and “DOWN” keys the user can cycle through the secondary parameters (those available depend upon the instrument options and configuration).

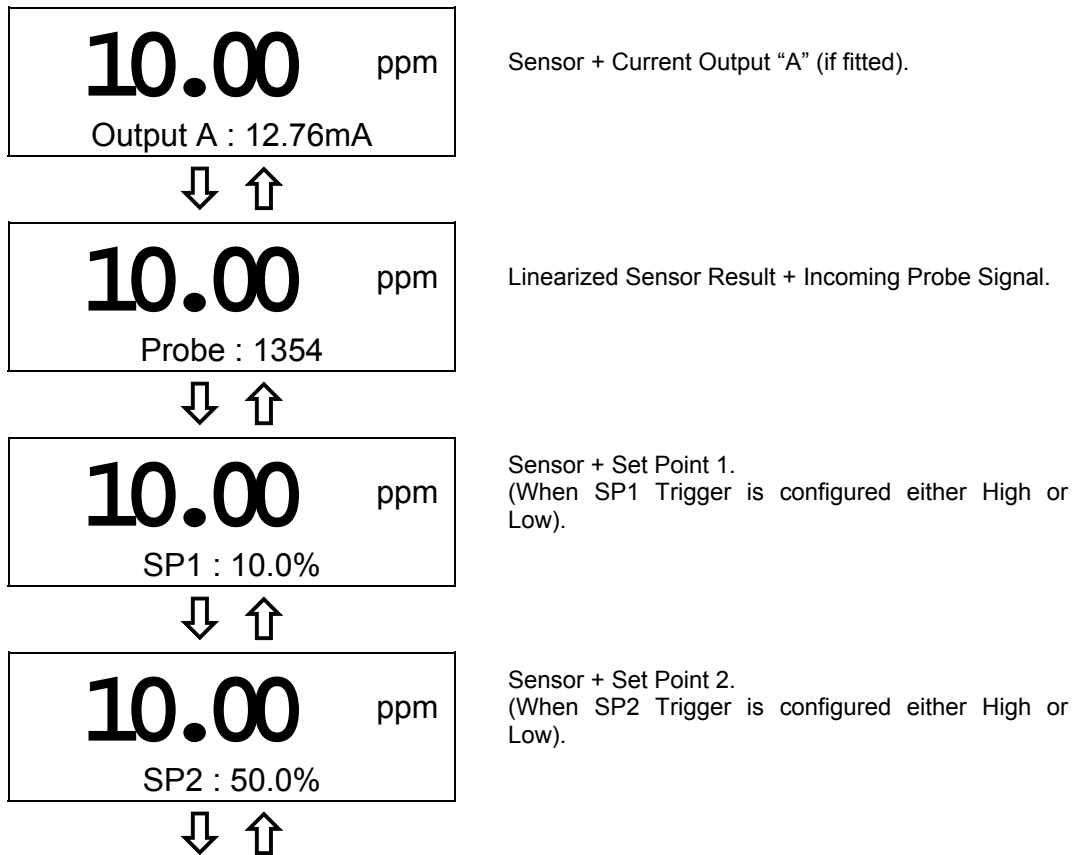

A Set Point will not be displayed if the relay has been disabled or configured to “**Cleaning**” operation (see page 20).

Selecting the parameter and pressing the “ENTER” key (provided that no error messages are present) will set the default secondary parameter. This is the default parameter that is displayed on the bottom line, when the unit is switched on, or as a result of returning to the normal display mode.

## ACCESS CODE

To protect the instrument set-up from unauthorised or accidental tampering, an access code must be entered. The “**Access Code**” menu will appear when the “PAGE” key is first pressed from the main display menu. A character on the upper right of the display will indicate whether access is permitted. The character will be a Key for permitted access and a Padlock for denied access. By default the access code will appear as 0000, however to unlock the instrument the correct code will need to be entered.



Use the enter and ↓ and ↑ keys to access “Set Level Code 1 or 2”.

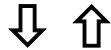

Use the ↓ and ↑ keys to adjust, and enter to accept.

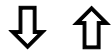

Use the ↓ and ↑ keys to adjust, and enter to accept.

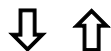

The default access codes are 0001 for level 1 and 0002 for level 2. During configuration it is much easier to use the instrument by making the default code for level 2 to 0000 otherwise access will time out in two minutes. First enter level 2 by entering 0002 on the keypad, the Padlock symbol should change to a Key. The arrow keys will now give you access to set level 1 and 2 code. Change level 2 code to 0000 and enter. The Key will change back to a Padlock. Press the page key and the access code will have changed to 0000 and the key symbol will appear giving you unlimited access.

Before returning the instrument to service change the level 2 access code back to 0002. Use the page key to access the “Access Code” menu page. Use the arrow keys to get to “Set level 2 Code” which will indicate 0000. Use the “ENTER” and arrow keys to set level 2 code to 0002. Pressing the “ENTER” key will change the Key symbol back to a Padlock.

## OPERATING MODE

### ON-LINE / OFF-LINE OPERATION

Selecting the “**Operating Mode**” menu will allow the user to place the unit in the “**Off-Line**” state. If the state is set to “**Off-Line**” the relays will be de-energised and the current output level frozen for the duration of the “**Off-Line**” state. When “**On-Line**” is selected the relays and current output will operate normally. The middle LED on the front panel display will indicate when the unit is “**Off-Line**”. In addition the user can set the unit to “**Off-Line**” by using the digital input terminal (See page 7).

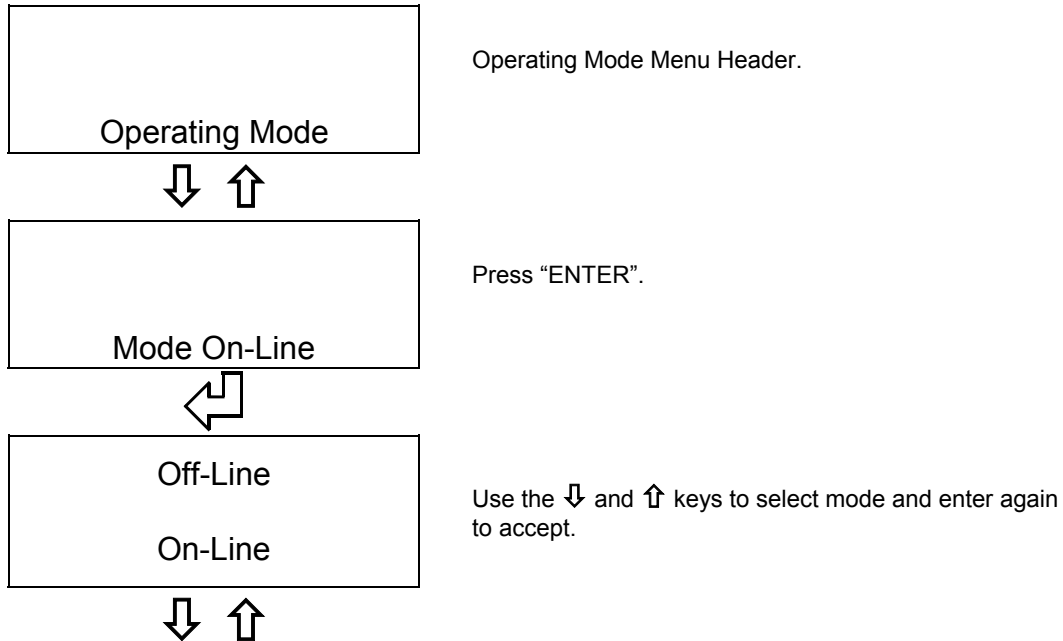

# PARAMETERS

The “Parameters” menu contains the basic configurations for the sensor inputs.

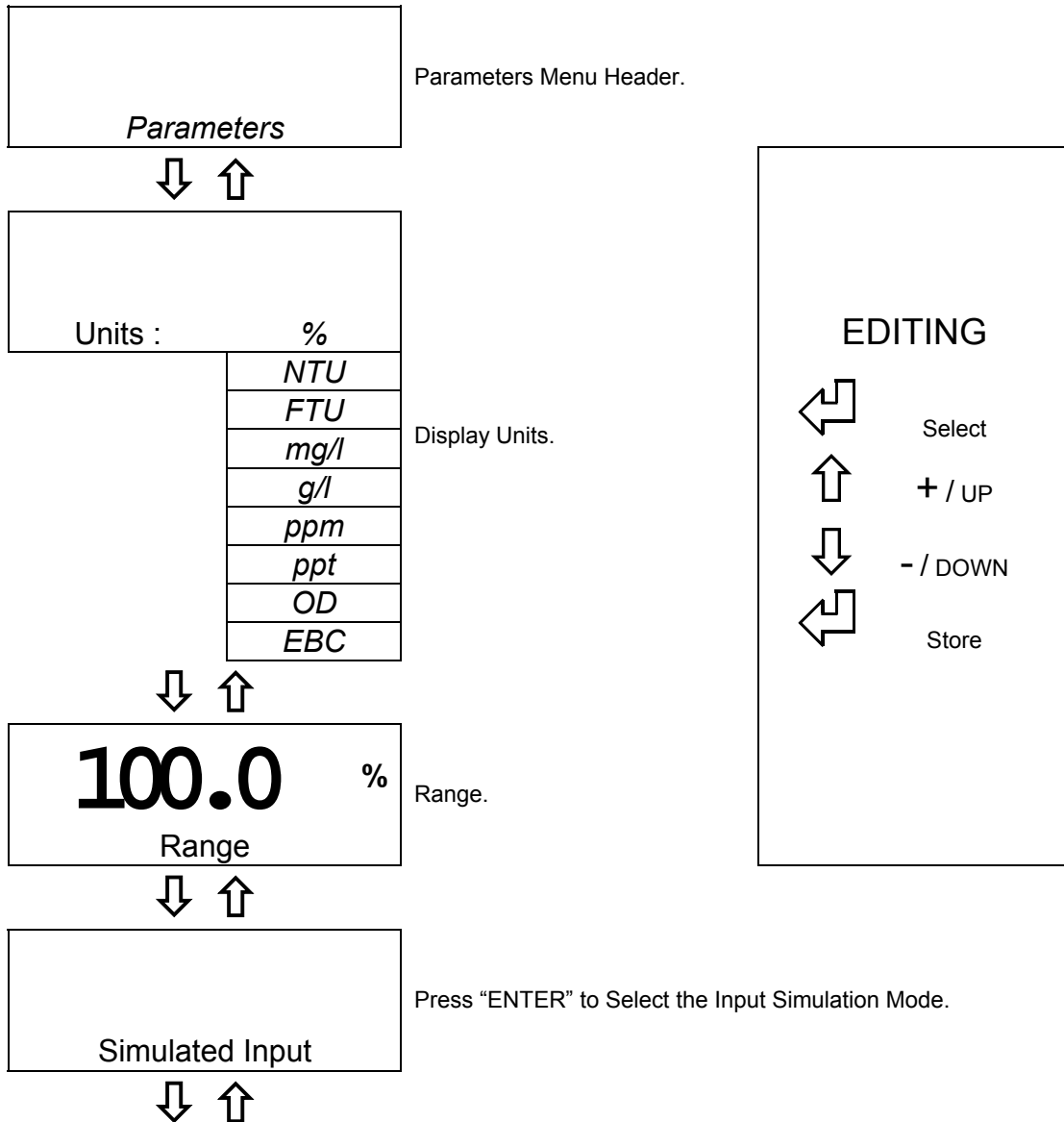

## DISPLAY UNITS

The MSSD53 primary display can be set-up to display in %, NTU, FTU, mg/l, g/l, ppm, ppt, OD and EBC. The relationship between these units and the incoming probe signal is determined by the linearization curve data (see page 24) and range setting (see below). They provide a qualitative rather than quantitative representation of the Solids present in the sample for display purposes and Set Point / Current Output processing. (See APPENDIX A – Suspended Solids).

## RANGE

The range for the display can be set by selecting the decimal point position giving 9.999, 99.99, 999.9 and 9999. These again are for display of range and Current Output purposes only. The ranges for the “%” units are limited to either 10.00% or 100.0%.

## SIMULATED INPUT

The facility exists within the MSSD53 to simulate the input sensor levels to test the set point and current output operation. This function allows the user to cycle up and down through the sensor range using the “UP” and “DOWN” keys and display the current output level, with the relays responding accordingly.

To select the ***“Simulated Input”*** menu item from the ***“Parameters”*** menu, press the “ENTER” key. The unit will now display the simulated input value. Pressing the “UP” and “DOWN” keys will cycle the displayed value between its minimum and maximum levels in steps of 1% of the total range (up to 105%). The relays and current output will respond as if the displayed value was an actual input, thus allowing the user to debug the set point and current output configurations.

# SET POINTS 1 & 2

The menu structures for both Set Points are identical, and provide a high level of flexibility in the configuration of the relay outputs as an alarm relay (see following text).

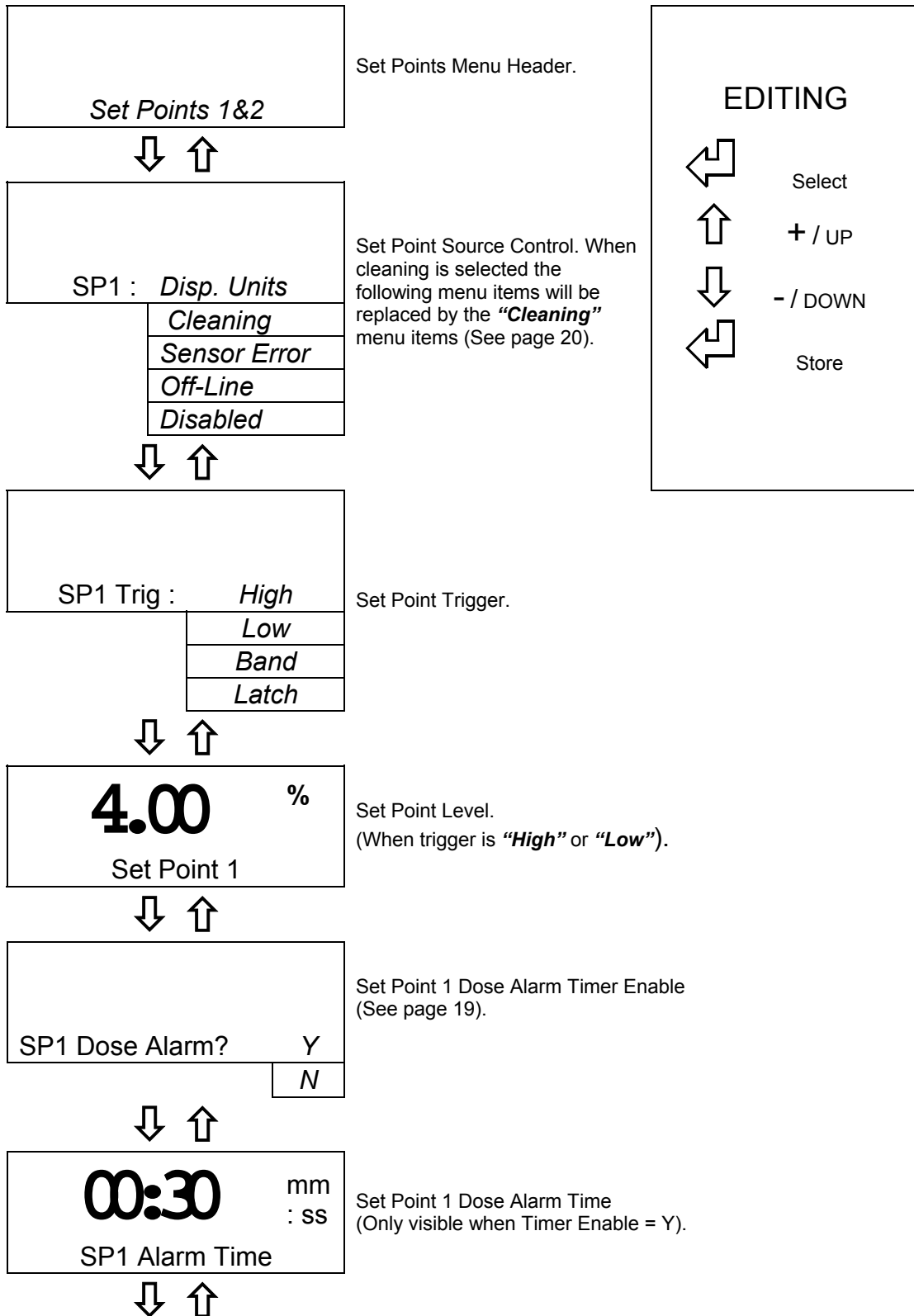

Continued on next page .....

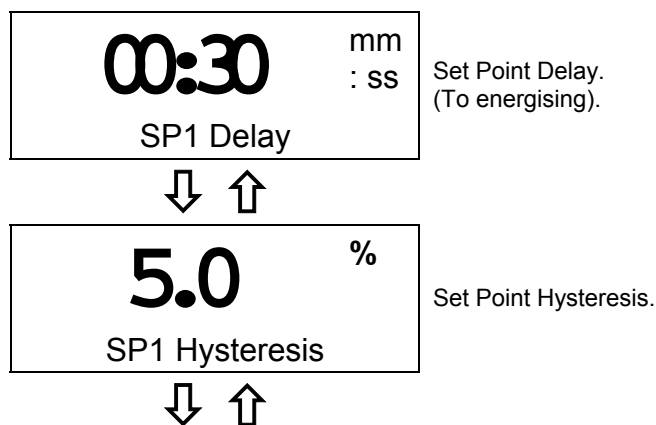

{Note. The “**Set Point 2**” menus continue from here, and are structured in the same manner.}

## SET POINT SOURCE

The set point operation on the MSSD53 is configured to operate from the main display units (derived by the linearization data). The set point can also be used to switch a cleaning device for timed washing of the sensor. For cleaning operation, the menu items are replaced by the sensor cleaning menu, see page 20.

## SET POINT TRIGGER

The set points can be configured to trigger in four ways. The level where the set point triggers is set by editing the value under the “**Set Point 1**” menu item in the “**Set Points**” menu. When the trigger is set to “**Band**” or “**Latch**” the “**Set Point 1**” menu disappears and “**SP1 Band High**” and “**SP1 Band Low**” menu items become available.

1. When the Trigger is set to “**High**”, the relay will be activated when the source input becomes greater than the set point.
2. When the trigger is set to “**Low**”, the relay will become activated when the source input is less than the set point.
3. When the trigger is set to “**Band**” the relay will become activated when the source input is either greater than the “**Band High**” level, or lower than the “**Band Low**” level.
4. When the trigger is set to “**Latch**” the relay will become activated when the source input becomes lower than the “**Band Low**” level, and will remain energised until it becomes higher than “**Band High**” level. It will then remain de-energised until the sensor input falls below the “**Band Low**” level again.

“**Delay**”: In order to prevent, short duration changes at the input affecting the relay operation a delay can be set before the relay is energised. If the input is still the same after the delay, then the relay will be energised.

“**Hysteresis**”: A facility to apply hysteresis to the set point level allows the user to avoid relay “Chatter” when the sensor input level approaches the set point level. “Chatter” is caused when the sensor input is sufficiently close to the set point value that noise on the signal repeatedly crosses the set point level, thus causing the relay to switch on and off rapidly. The hysteresis level should therefore be set to be a little larger than the input noise level.

## DOSE ALARM TIMERS

The dose alarm timer can be used to prevent overdosing under many different fault conditions, such as sensor failure or wiring faults. When the timer is enabled the user can set the “**Alarm Time**”. If the associated relay remains energised for longer than the “**Alarm Time**” the alarm will activate, de-energising the relay to prevent over-dosing and flash the relative set point LED on the front panel. The display will also flash a warning message when the alarm is activated.

To cancel the warning, and reactivate the set point, the user need only press the “**ENTER**” button on the front panel. N.B. If more than one Alarm is active, Set Point 1 takes priority over Set Point 2 and they are cancelled in that order by additional presses of the “**ENTER**” button.

### SENSOR CLEANING

These set points can be configured to operate a jet spray wash on a timed cycle. Its purpose is to prevent accumulation of particulate matter on the active surfaces of the sensor. The cleaning control menus can be accessed from either of the **“Set Points 1 & 2”** or **“Current Output”** menus, when one or the other has been set to cleaning mode (see Set Point Source page 19, or Current Output Source Page 22).

↓ ↑

00:30	mm: ss
Cleaning Duration	

The duration of the cleaning operation.  
(5 seconds to 10 minutes).

↓ ↑

01:30	hh: mm
Cleaning Interval	

The interval between cleaning operations.  
(5 minutes to 48 hours).

↓ ↑

Clean :	On-Line
	Off-Line

System state when cleaning. When “Off-Line”, the other relays/current outputs are held at their present value.

↓ ↑

00:05	mm: ss
Cleaning Recovery	

Sensor recovery, time from end of cleaning to returning to “On-Line” state”.  
(5 seconds to 10 minutes).

↓ ↑

Cleaning Delay	Y
	N

When operating in “On-Line” state, “Y” forces the cleaning to wait until all relays are inactive.  
(Only appears when state = “On-Line”).

Manually taking the instrument Off-Line will prohibit or terminate a “Clean” cycle. If the instrument is Off-Line when a “Clean” cycle is requested, either automatically or manually, the message **“Cleaning Delayed”** will flash on the bottom row of the display until it is either cancelled using the “ENTER” key, or cleaning is initiated by placing the unit back in the On-Line state. The instrument can be taken Off-Line during a “Clean” cycle. This will de-energise the Set Point relays and freeze the current output, which could otherwise cause chaos in the control system as a result of cleaning solution being sprayed onto the sensor.

By selecting the Off-Line option in the **“Clean”** menu, spurious relay / current output changes are prevented during the **Duration** and **Recover** periods. Normal operation is restored during the **Interval** period. The clean **Delay** function gives priority to the control relays. This means that a “Clean” cycle will be delayed for as long as necessary until the control relays are in the “Off” state.

A manual clean cycle can be initiated by a remote switch/contacts connected to the instrument digital input terminals (see page 7). The “Clean” cycle software runs automatically and continuously from power up if selected, beginning with the **Interval** period. It can only be stopped by changing the operating mode of the output, which it is controlling.

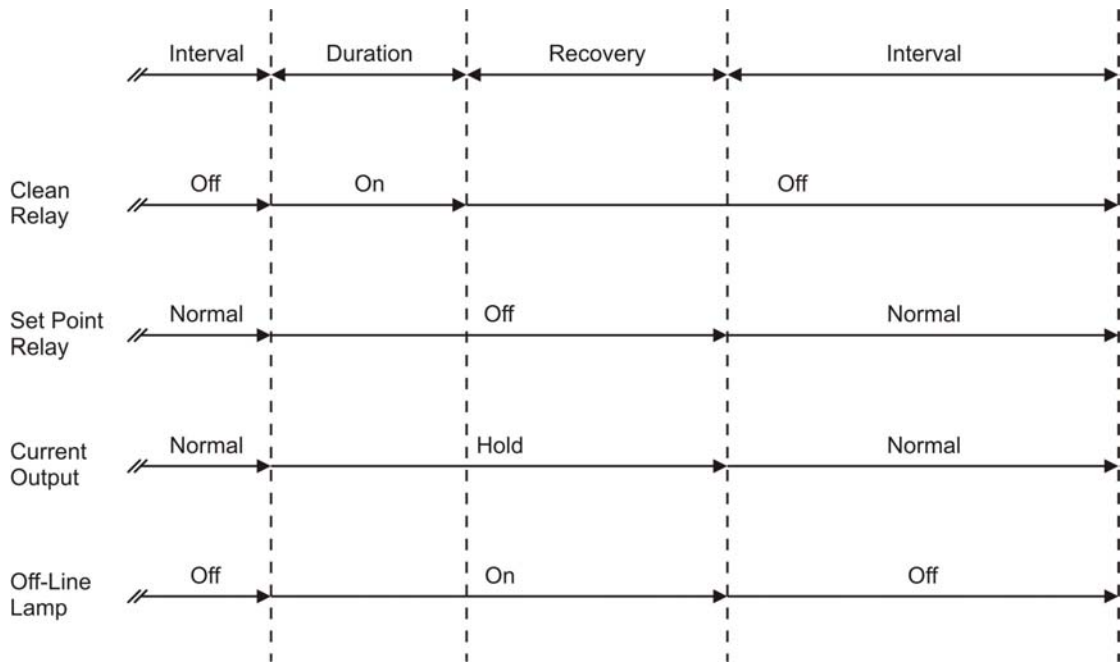

**Figure 9: Typical Operation with Clean Off-Line**

# CURRENT OUTPUT

The current output menu structure contains all of the necessary set-up functions to configure the current output source.

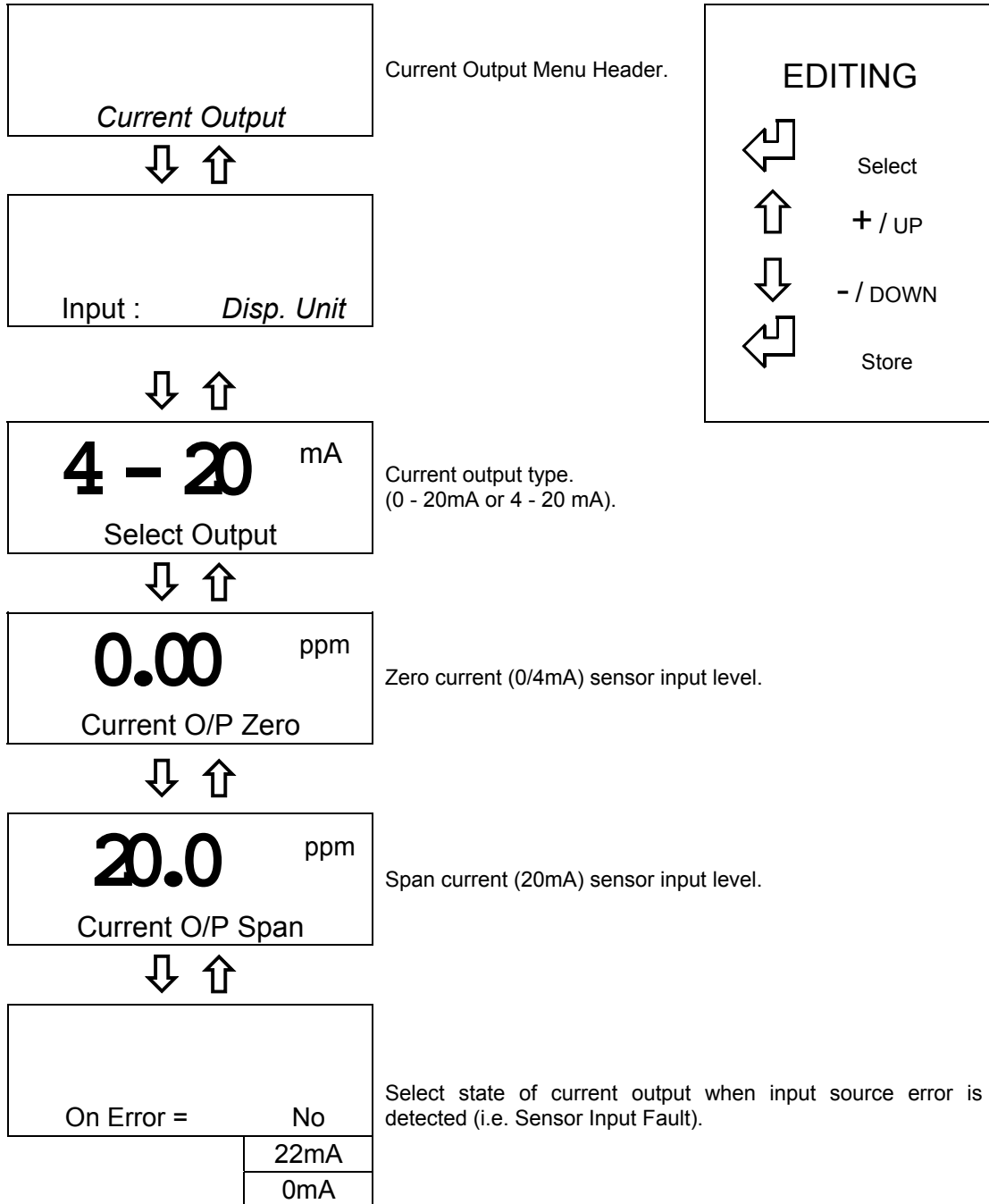

## INPUT

The input for the current output is the display units (derived from the linearization curve).

## OUTPUT RANGE

The output range for the current output can be set to one of two ranges, either 0 - 20mA or 4 - 20mA. This selection sets the limits of the zero and span output levels. The output will continue to provide an extrapolated output above (>20mA) and below (<4mA) these points but will flag an error message on the main display. The maximum current output limit is approximately 22mA, the minimum limit is 0mA (i.e. the unit cannot source a negative current).

## **ZERO & SPAN**

The zero and span levels are set as the limits of the source input. This provides a totally flexible method of configuring the current output. The zero can be set anywhere within the input source range and the span as little as 5% of the selected range, providing total control of the output range and offset. An inverse relationship can easily be achieved by simply setting the zero level to be higher than the span level.

## **PROPORTIONAL CONTROL**

Many devices such as motor speed controllers, valve actuators, or stroke positioners will accept an analogue 4 - 20 mA control signal.

It is possible to use the measurement signal from the instrument as a control signal. By setting the point at which the output is 4 mA as the set point (e.g. 7.00 ppm) and the point at which the output is 20 mA as the proportional band (e.g. 4.00 ppm) a simple form of proportional control is achieved. If this signal was used to drive a valve actuator, the valve would be fully open at 4.00 ppm; half open at 5.50 ppm and closed at 7.00 ppm.

## **ERROR CONDITION**

The current outputs can be programmed to output 22mA or 0mA when an error is detected on the source (i.e. Sensor Fault, Over or Under Range), to provide remote warning of error conditions or to ensure fail safe operation.

# LINEARIZATION

With many solutions the rate of infrared absorption is non linear as the solids concentration increases. The purpose of this function is to take the probe signal values from several samples and convert this non-linearity to a straight-line output. In many cases this is the only calibration procedure required.

To enter points in the linearization table, first prepare or obtain from the process a sample which is as close as possible to the maximum range of suspended solids for which the instrument is to be calibrated. This will be your 100 % point. For a two-point linearization the lower point is usually water. Where you want to enter more than two points, dilute your process sample to correspond with, for example, 25%, 50% and 75%. Insert the sensor in the samples and measure the probe signal values making a table of probe signal value against percentage. Enter these values in the corresponding points in the **“Linearization”** menu.

The data can be entered in any order as it is sorted into ascending probe signal values within the software. A minimum of 2 points are required and any unused points should be disabled by setting the probe signal for that point to 0. Two curves are provided (A & B) which are user selectable. These curves are stored along with the set-up data when a **“Save”** is performed in the **“Save / Restore”** menu (see page 28). By default the two curves are set as two point (straight-line) linearization (see default settings page 36).

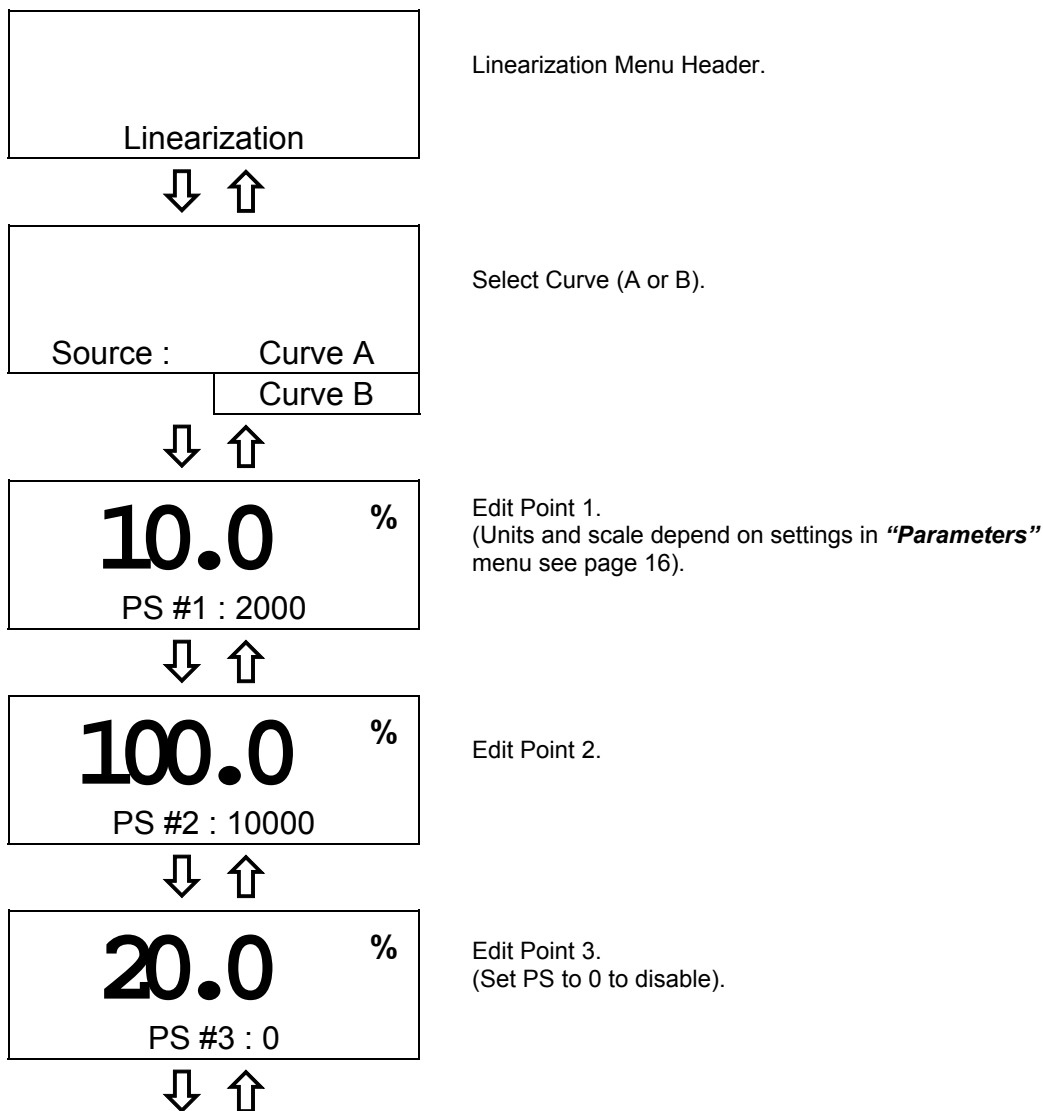

Continued on next page .....

**40.0** %  
PS #4 : 0

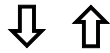

Edit Point 4.  
(Set PS to 0 to disable).

**60.0** %  
PS #5 : 0

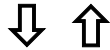

Edit Point 5.  
(Set PS to 0 to disable).

The unit will display an error message if there are less than two points, and when the incoming probe signal is less than the lowest data point or greater than the highest data point (see APPENDIX E – Error Messages on page 42). An under-range error will occur if the resulting linearized value is less than 0. An over-range error will occur if the resulting value is greater than 9999 (or 10.00/100.0 for the % ranges).

The user is advised to record the curve data in the spaces provided in APPENDIX C – Customer Set-Up (page 38). In APPENDIX A – Suspended Solids (page 35) the user is provided with some basic linearization curves along with a brief explanation of Suspended Solid measurement.

## OPTIMISATION

The MSSD53 provides the facility within the "**OPTIMISATION**" menu to adjust the current output to match any receiving instrument, so that the indicated values of both instruments are the same. To adjust the current output select the "**Current Output offset**" menu item. Keep in mind that the current output cannot go below 0mA and that the maximum offset is  $\pm 2\text{mA}$ .

The "**Optimisation**" menu also provides Zero and Span offsets so that the instrument and lab results correlate.



Optimisation Menu Header.

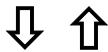

### **Current Output Offset.**

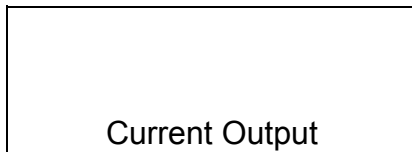

Current Output Calibration.  
(0,4 & 20mA levels).



Press "ENTER" to start calibration.

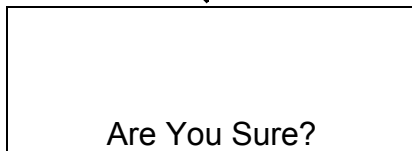

The unit will request confirmation before beginning the calibration.



Press "ENTER" to confirm or any of the other three buttons abandons the calibration.

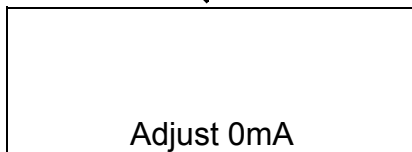

Use the ↓ and ↑ keys to adjust the output to give 0.00mA at the output monitor.



Press "ENTER" to finish.

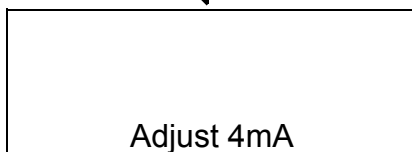

Use the ↓ and ↑ keys to adjust the output to give 4.00mA at the output monitor.



Press "ENTER" to finish.

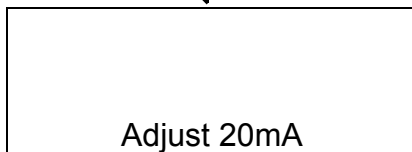

Use the ↓ and ↑ keys to adjust the output to give 20.00mA at the output monitor.



Press "ENTER" to finish.

*Continued on next page .....*

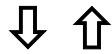

Sensor Offset		Y
		N

### Sensor Offset

Press "ENTER" key to access this option and select "Y".



Offset Zero Adj.	
------------------	--

Press the "ENTER" key and use the ↓ (subtract) and ↑ (add's) keys to adjust the zero offset.

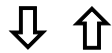

Offset Span Adj.	
------------------	--

Press the "ENTER" key and use the ↓ (subtract) and ↑ (add) keys to adjust the span offset.

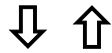

Reset Offsets	
---------------	--

### Reset Offset

Press the "ENTER" key to access this option.



Are You Sure?	
---------------	--

Press the "ENTER" key to access this option.

The unit will request confirmation before beginning the "**Reset Offsets**" function.



Press enter to confirm. This will reset to zero all adjustments made to current, zero and span offsets.

## SAVE / RESTORE

One of the many new features in the MSSD53 instrument is the availability to the user of a set-up storage and recovery facility. Using these functions the user can save an instrument set-up into either of two stores, or restore a previously saved set-up from one of the two stores or the default set-up.

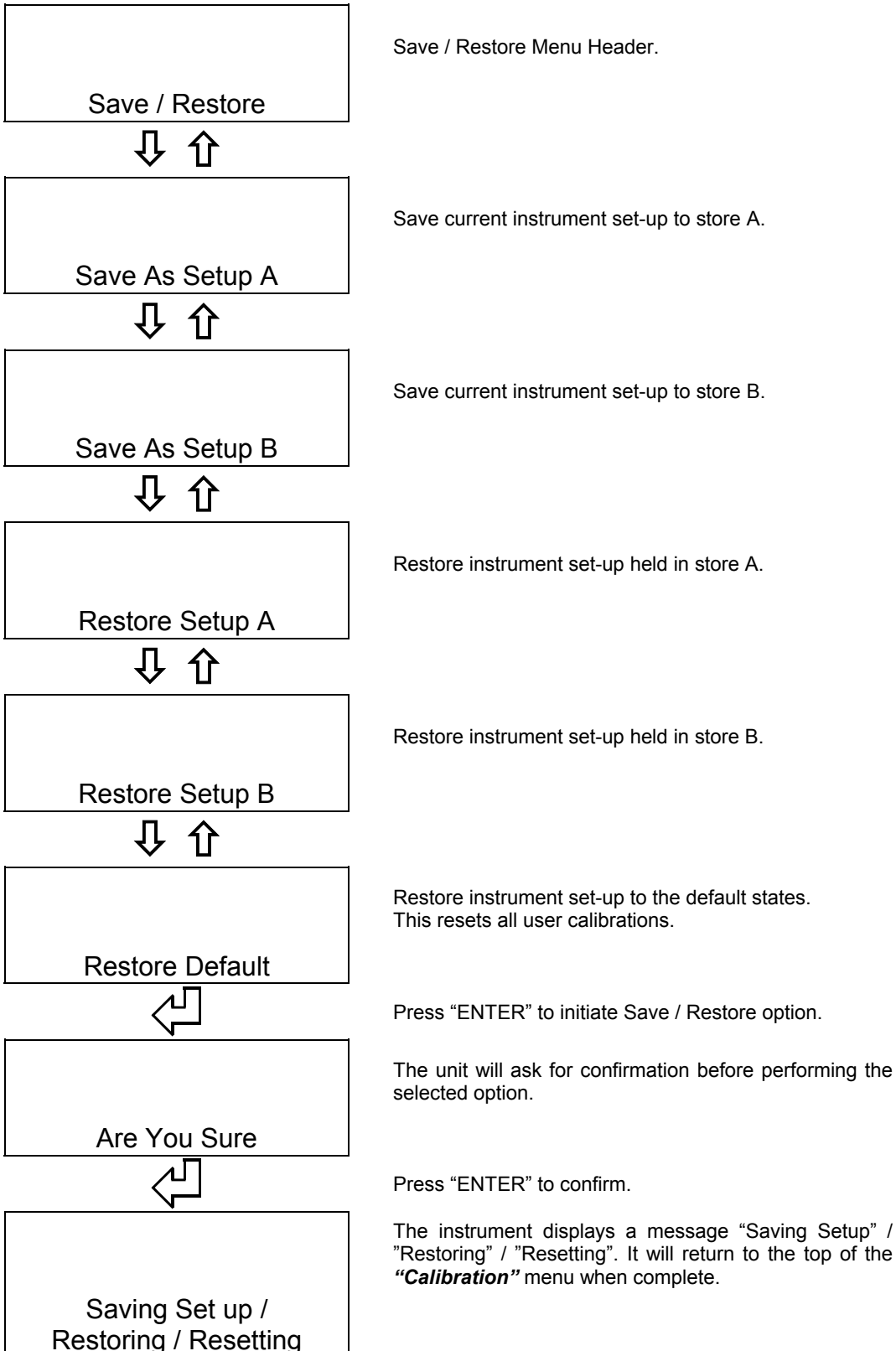

To use these functions select the "**Save / Restore**" menu item and use the "UP" and "DOWN" keys to select the required function. Pressing the "ENTER" key will prompt the unit to ask for confirmation.

Pressing the "ENTER" key again will initiate the function. The unit will then perform the function and then return to the main menu.

This facility is very useful when testing or faultfinding is required. The set-up can be stored prior to testing and restored once testing is complete. The default set-up is provided to give a basic instrument set-up.

***{Note. There is no protection for the set-up stores other than the systems request for confirmation, so be very careful not to overwrite already saved set-ups.}***

# CONFIGURATION

The unit also includes a configuration menu that sets up some basic operating parameters for the instrument.



Configuration menu header.

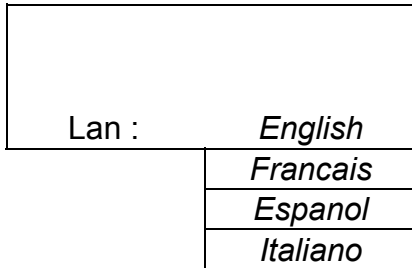
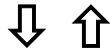

The MSSD53 has the ability to support multilingual text display, this can be selected from this menu.

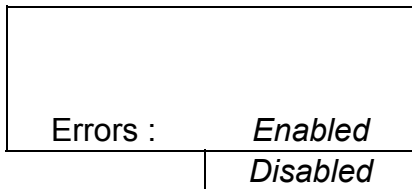
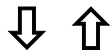

This function will disable/enable the flashing error messages on the main display. When disabled, a flashing "Bell" character will indicate an error is present.

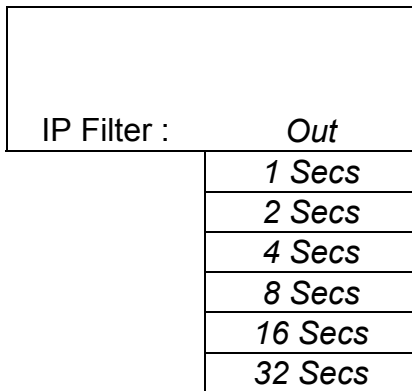
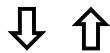

Input Filtering (Averaging).  
When very noisy environments are encountered, this function will allow the user to filter the sensor readings by taking a running average over the time period selected. (From 1 to 32 seconds).

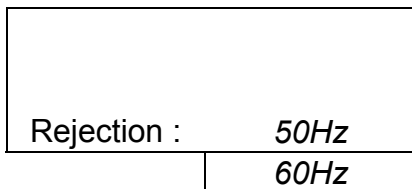
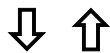

Select mains frequency to provide improved noise rejection.

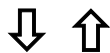

## FAULT FINDING

### NOTE: THERE ARE NO USER SERVICEABLE PARTS INSIDE THE UNIT.

The MSSD53 has been designed to include a wide range of self-diagnostic tests, some of these are performed at switch on and some on a continuous basis. This guide aims to provide a route to diagnosing and correcting any faults that may occur during normal operation. The table shown in APPENDIX E – Error Messages (page 42) gives a list of the error messages that the MSSD53 generates, along with their probable causes. If the fault has not been cleared after these checks have been made contact your local representative or Barben Analyzer Technology, LLC. Please have as much of the following information available as possible in any communication with Barben Analyzer Technology, LLC to enable quick diagnosis and correction of the problem.

1. Serial number of the instrument.
2. The approximate date of purchase.
3. Software Version (Displayed at Switch On).
4. Details of the program settings and application.
5. Electrical environment and supply details.
6. Circumstances under which the fault occurred.
7. The nature of the fault or faults.
8. Any error messages that are displayed.
9. The sensor type, cable length and type.
10. Current output configuration.
11. Relay connection configuration.

### THE INSTRUMENT APPEARS DEAD

Check that power is available to the unit. Use an appropriate voltmeter to check that the power supply voltage at the connector is within the limits defined on the connector label. Check that the power cable is securely and correctly attached. There are no user serviceable fuses fitted within this unit.

### THE ACCESS CODE DOES NOT WORK

It is probable that the access code has either been changed or the operator does not recall the code correctly. Contact your local distributor or Barben Analyzer Technology, LLC should this problem arise.

### THE SENSOR READING IS CONSTANTLY OVER-RANGE OR UNDER-RANGE

- ◆ Are any E1X error messages present? (See APPENDIX E – Error Messages, page 42). If so check the probe for fouling or damage and check that the cable is correctly and securely attached at the instrument terminals. Check for damaged or broken cables. If all appears secure and correct contact a service engineer for guidance.
- ◆ If no E1X error messages are present check the probe signal reading on the display. Check the probe signal reading with the sensor in a sample solution with a high and low probe signal value. If the probe signal is not reading as would be expected contact a service engineer for advice.
- ◆ Re-check the Linearization data (see page 24).
- ◆ Re calibrate the probe in the “High” and “Low” sample solutions. (see APPENDIX D – Calibration / Optimisation page 40). If necessary, use the “**Restore Defaults**” function in the “**Save / Restore**” menu (see page 28) to remove the user calibration.
- ◆ Where extension cables have been used, try connecting the sensor directly to the instrument.
- ◆ If possible check the sensor using another MSSD53 transmitter.

### THE SENSOR READING IS INCORRECT

- ◆ Ensure that the sensor is mounted properly, that there is at least 25mm (1”) of clearance around the head of the probe.
- ◆ Establish that the sensor is specified to work within the range that is being monitored.

### CURRENT OUTPUT IS INCORRECT OR NOISY

- ◆ Check that the maximum load for the current loop has not been exceeded. (1000Ω).
- ◆ Check that the source signal for the current output (sensor input i.e. probe signal value) is correct and not unduly noisy. You could also increase the time constant of the input filter (See page 30).
- ◆ Check that the terminals have been wired correctly (see page 5).

- ◆ Check that the cable screen is attached to “Earth” at one end, and that the cable does not pass too close to a power cable (see page 5).
- ◆ Check that the current output has been configured properly (see page 22), and that a sufficiently large span has been defined (at least 5% of total range being measured).

### **RELAYS APPEAR TO MALFUNCTION**

- ◆ Check that the unit is “On-Line” (see page 15).
- ◆ Check that the Set Point configuration is correct (see page 18).
- ◆ If the relays are vibrating or “chattering” as they pass the set point, check the hysteresis setting (see page 18) and increase if necessary.
- ◆ Ensure that the relays are connected properly (see page 6) and that the voltage/current levels are not exceeding the specification (see page 1).
- ◆ Check that the instrument input cables are not picking up excessive noise, (see page 3).
- ◆ Use the “**Simulated Input**” menu (see page 16) to check the Set Points Function.

### **A BELL SYMBOL IS FLASHING ON THE DISPLAY**

The system has detected an error but the error messages have been disabled in the “**Configuration**” menu (See page 30). Enable the error messages, correct the error and then disable the error messages only if necessary.

## GUARANTEE AND SERVICE

Products manufactured by Barben Analyzer Technology, LLC (other than sensors) are guaranteed against faulty workmanship and materials for a period of two years from the date of dispatch from the factory. Finished goods not manufactured by Barben Analyzer Technology, LLC are subject to separate agreements.

Sensors are guaranteed against faulty material or workmanship for a period of 12 months providing that the sensor has been used within the published specifications. All sensors made by Barben Analyzer Technology, LLC are thoroughly tested to their published specification before despatch. As Barben Analyzer Technology, LLC has no control over the conditions in which these sensors are used, no further guarantee is given, although any complaints concerning their operation will be carefully investigated.

Goods for attention under guarantee (unless otherwise agreed) must be returned to the factory carriage paid and, if accepted for free repair, will be returned to the customer's address free of charge. Before goods are returned to the factory for either Warranty or Service please contact Barben Analyzer Technology by fax or email for a Return Material Advice (RMA) number. Arrangements can also be made for repair on the customer's site, in which case a charge may be made for the engineer's time and expenses.

If any services other than those covered by the guarantee are required, please contact Barben Analyzer Technology, LLC direct.

N.B. Overseas users should contact their Barben Analyzer Technology, LLC nominated representative first.

This page intentionally blank

## APPENDIX A – SUSPENDED SOLIDS

### SUSPENDED SOLID MEASUREMENT

Suspended solid measurement is a qualitative measure of the light absorbed by particles suspended in a liquid medium. A light is shone through a sample of the medium and detected on the opposite side to give a measure of the optical density of the liquid. If the general properties of the medium are known, this measure can be equated to a measure of the amount of suspended solids in the medium.

However this can become significantly more complicated due to the variations in the size and light absorption characteristics of the particles of the suspended solid being monitored. For this reason each medium/particle combination needs to be calibrated with the instrument being used.

Some factors are far too complicated to be modelled or compensated for (bubbles, refraction effects due to elevated temperatures etc) and must be minimised at the monitoring point.

### PRINCIPLES OF THE BARBEN SENSOR

The probes supplied by Barben Analyzer Technology, LLC utilise a Barben method of measuring suspended solids. This eliminates errors due to ageing of the optical components (LED), and fouling of the sensor. The probe consists of two light emitting diodes (LEDs, emitting infrared wavelengths of light) and two photo-detectors. By switching each LED ON in turn and measuring the two resultant photo-detector currents, a ratio result is created which removes variations due to component drift and variations in the build up of dirt on the surfaces of the optical components. The result is a "Probe Signal" (a calculated number) that ranges from approx 1000 to 16000 giving a measure of the optical quality of the medium being monitored.

### LINEARIZATION DATA

The relationship between the probe signal and the standard units of measurement for suspended solids is often non-linear. For this reason the MSSD53 has been designed to include user selectable linearization to provide a much closer conversion from the incoming probe signal to the displayed engineering units (see page 24). Up to five points can be entered, the more points that are used the more precise the conversion will be.

The best way to calibrate the instrument is to use samples of known quantity and determine the linearization points by dilution. This is best done in a controlled (preferably a laboratory) environment to obtain the most precise and repeatable results. The following linearization data has been derived from laboratory testing by Barben Analyzer Technology, LLC.

Example No.1: Whole Milk (4% Fat) using an S20 series sensor

100% Water	Probe Signal = 1535
1% Milk	Probe Signal = 1883
2% Milk	Probe Signal = 2242
5% Milk	Probe Signal = 2872
10% Milk	Probe Signal = 3294
25% Milk	Probe Signal = 3911
50% Milk	Probe Signal = 4525
100% Milk	Probe Signal = 5035

Example No.2: Cream (40% Fat) using an S10 series sensor

100% Water	Probe Signal = 1510
100% Milk (4% Fat)	Probe Signal = 4074
50% Cream (20% Fat)	Probe Signal = 4919
100% cream (40% Fat)	Probe Signal = 5244

## APPENDIX B – FACTORY DEFAULT SET-UP

<b>Operating mode</b>	On-Line	
<b>Parameters</b>		
Units	%	
Range	0 to 100.0	
<b>Set Point 1</b>		
SP1 Source	Display Units	
SP1 Trigger	Low	
Set Point 1. Applies when SP1 Trigger = Low or High	10.0%	
SP1 Band High. applies when SP1 Trigger = Band or Latch	10.0%	
SP1 Band Low. Applies when SP1 Trigger = Band or Latch	0.0%	
SP1 Dose Alarm	No	
SP1 Alarm Time (mm:ss)	05:00	
SP1 Delay (mm:ss)	00:00	
SP1 Hysteresis (% of SP Level)	5.0%	
<b>Set Point 2</b>		
SP2 Source	Off-Line	
SP2 Trigger	High	
Set Point 2. Applies when SP2 Trigger = Low or High	10.0%	
SP2 Band High. applies when SP2 Trigger = Band or Latch	10.0%	
SP2 Band Low. Applies when SP2 Trigger = Band or Latch	0.0%	
SP2 Dose Alarm	No	
SP2 Alarm Time (mm:ss)	05:00	
SP2 Delay (mm:ss)	00:00	
SP2 Hysteresis (% of SP Level)	5.0%	
<b>Cleaning</b>		
Duration (mm:ss)	00:05	
Interval (hh:ss)	01:00	
Mode	Off-Line	
Recovery (mm:ss)	00:05	
Delay	N	
<b>Current Output A</b>		
Input A	Display Units	
Output A	4-20mA	
Output A Zero	0.0%	
Output A Span	100.0%	
<b>Linearization Curve A</b>		
Point 1	10.0%	1500
Point 2	100.0%	6500
Point 3	20.0%	0
Point 4	40.0%	0
Point 5	60.0%	0

<b>Linearization Curve B</b>		
Point 1	10.0%	1500
Point 2	100.0%	6500
Point 3	20.0%	0
Point 4	40.0%	0
Point 5	60.0%	0
<b>Configuration</b>		
Language	English	
Errors	Enabled	
Input Filter	Out	
Rejection	50Hz	

## APPENDIX C – CUSTOMER SET-UP

Instrument Serial No. : \_\_\_\_\_

Sensor Serial / Type No. : \_\_\_\_\_

<b>Parameters</b>	
Units	
Range	
<b>Set Point 1</b>	
SP1 Source	
SP1 Trigger	
Set Point 1. Applies when SP1 Trigger = Low or High	
SP1 Band High. applies when SP1 Trigger = Band or Latch	
SP1 Band Low. Applies when SP1 Trigger = Band or Latch	
SP1 Dose Alarm	
SP1 Alarm Time (mm:ss)	
SP1 Delay (mm:ss)	
SP1 Hysteresis (% of SP Level)	
<b>Set Point 2</b>	
SP2 Source	
SP2 Trigger	
Set Point 2. Applies when SP2 Trigger = Low or High	
SP2 Band High. applies when SP2 Trigger = Band or Latch	
SP2 Band Low. Applies when SP2 Trigger = Band or Latch	
SP2 Dose Alarm	
SP2 Alarm Time (mm:ss)	
SP2 Delay (mm:ss)	
SP2 Hysteresis (% of SP Level)	
<b>Cleaning</b>	
Duration (mm:ss)	
Interval (hh:ss)	
Mode	
Recovery (mm:ss)	
Delay	
<b>Current Output A</b>	
Input A	
Output A	
Output A Zero	
Output A Span	
<b>Linearization Curve A</b>	
Point 1	
Point 2	
Point 3	
Point 4	
Point 5	

<b>Linearization Curve B</b>		
Point 1		
Point 2		
Point 3		
Point 4		
Point 5		
<b>Configuration</b>		
Language		
Errors		
Input Filter		
Rejection		

## APPENDIX D – CALIBRATION / OPTIMISATION

### CALIBRATION / OPTIMISATION PROCEDURES

When trying to calibrate an instrument to measure suspended solids it is often difficult to keep the solids in suspension long enough for an accurate calibration to be made. The use of a magnetic stirrer in many cases will improve this.

In the linearization menu the probe signals should have been entered from the prepared samples and the output will now be linear with percent solids. In many cases this is all that is required.

When the instrument is installed into the process, the indicated readings can be verified by sample analysis in the laboratory. The readings produced from the laboratory may not correlate with the instrument readings. This is more likely in liquids that have large particles which separate out easily. eg yeast, waste water, or white water in the paper industry.

### ZERO OFFSET ADJUSTMENT

To correct for any discrepancies, the MSSD53 has two adjustments in the *“Optimisation”* menu. A *“Zero offset”* adjustment and a *“Span offset”* adjustment. The Zero offset adjustment will either add or subtract a bias value to the zero point which will shift the entire curve by this value. The slope of the curve is unchanged and the effect is illustrated below. In this example there is a 5g/l difference over the entire measuring range and by offsetting the zero by  $-5\text{g/l}$  the two lines will coincide.

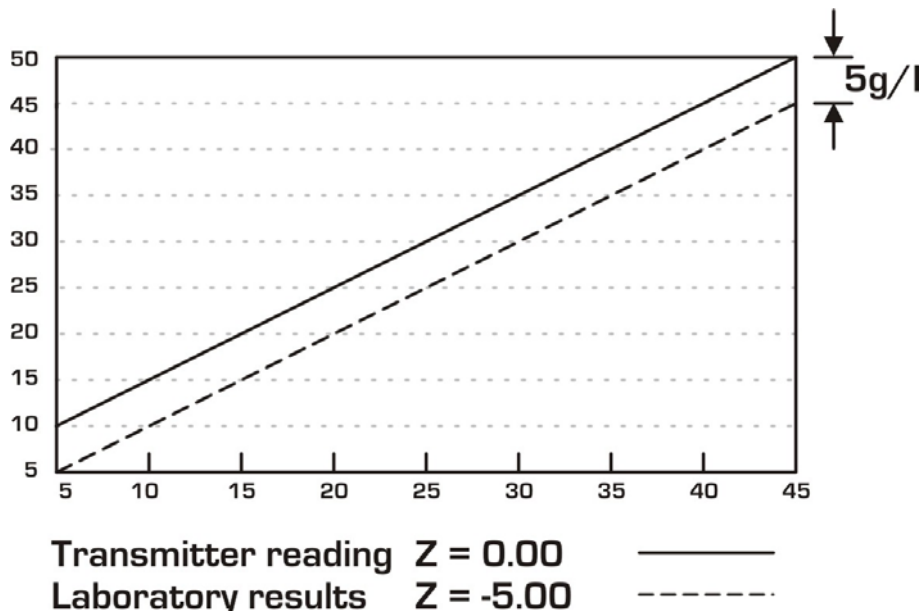

### SPAN OFFSET ADJUSTMENT

If the zero point of the measuring range is correct but the highest calibration point is incorrect then the Span Offset adjustment will shift the end point of the curve up or down. This changes the slope of the output curve. The zero point is unchanged and intermediate points are adjusted in proportion to the amount entered.

This function is illustrated below and the span offset would have to be adjusted by  $-5\text{g/l}$  to correct the slope of the output so that the two lines will coincide.

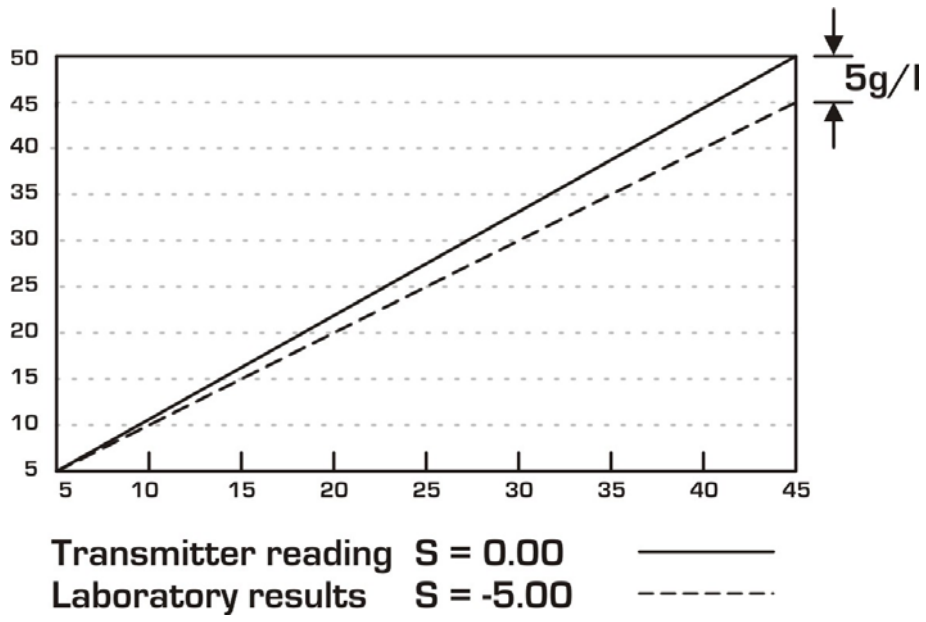

## APPENDIX E – ERROR MESSAGES

<i>Switch On Diagnostic Errors</i>	
<b>E01 :</b>	<b>Internal Processor RAM Read/Write Error</b> Try switching the unit OFF then ON again. If the message persists, consult with your supplier, as this unit will require to be returned for repair.
<b>E02 :</b>	<b>EPROM Checksum Error</b> The software runs a checksum test on the program memory store at power ON, to ensure that the integrity of the software has not been compromised. Switch the unit OFF then ON again. If the error message persists call an local distributor or Quadbeam Technologies Ltd.
<b>E03 :</b>	<b>External RAM Read/Write Error</b> Try switching the unit OFF then ON again. If the message persists, consult with your supplier, as this unit will require to be returned for repair.
<b>E04 :</b>	<b>Set-up Checksum Error</b> The instrument configuration has, for some reason, become corrupted. Restore a set-up from store A or B, or the factory default set-up.
<b>E05 :</b>	<b>Store A Checksum Error</b> The data in set-up store A has been corrupted. Save the current set-up back to store A.
<b>E06 :</b>	<b>Store B Checksum Error</b> The data in set-up store B has been corrupted. Save the current set-up back to store B.
<b>E07 :</b>	<b>Factory Calibration Checksum Error</b> The factory calibration data for this instrument has been corrupted. The instrument will need to be re-calibrated. Consult your local distributor.
<b>E08 :</b>	<b>User Calibration Checksum Error</b> The user calibration data has been corrupted. Reset the user calibration and re-enter the data.

<i>Probe Diagnostic Errors</i>	
<b>E11 :</b>	<b>Probe Communications Error</b> The communications Link between the sensor interface PCB and the main unit controller is malfunctioning. Return the unit to your local distributor or Quadbeam Technologies Ltd for repair.
<b>E12 :</b>	<b>No Signal</b> No sensor connected or the detector current is equal to “zero”. The PSU goes to 16000
<b>E13 :</b>	<b>Signal Overload</b> The gain step is equal to 0 and the A/D output is over 255. This cannot happen in a liquid but could happen if the sensor is in full sunlight. The PSU goes to 16000
<b>E14 :</b>	<b>Partial Depletion</b> Large difference between the detectors, i.e. one of them is very dirty. This alarm will only come up if there is a difference of 3:1 between the detectors. The PSU will go to 16000
<b>E15:</b>	<b>Full Depletion</b> Attenuation to high or the real probe signal goes above 14000. The PSU will go to 16000

<b>E16 :</b>	<b>Filter Status Error</b> The state of <b>“Rejection”</b> in the <b>“Configuration”</b> menu does not agree with the filter frequency setting of the sensor interface PCB. Return the unit to your local distributor or Quadbeam Technologies Ltd for repair.
<b>E17 :</b>	<b>CIP Status Error</b> The CIP status of the instrument does not agree with that of the sensor interface PCB. Return the unit to your local distributor or Quadbeam Technologies Ltd for repair.
<b>E18:</b>	<b>Probe error</b> The measurement is not valid. This alarm will only show for a maximum of 20 seconds when it will either go away, or go to one of the above error numbers.

**Sensor Input Errors**

<b>E31 :</b>	<b>Invalid Linearization Curve</b> A minimum of 2 linearization points are required.
<b>E32 :</b>	<b>Linearization Over-range</b> The linearization result is greater than 9999 (or 100.0% for %).
<b>E33 :</b>	<b>Linearization Under-range</b> The linearization result is less than 0.
<b>E34 :</b>	<b>Curve Limit</b> The incoming probe signal is less than the lowest point in the linearization curve.
<b>E35 :</b>	<b>Curve Limit</b> The incoming probe signal is greater than the highest point in the linearization curve.

**Current Output Errors**

<b>E41 :</b>	<b>Current Output Hardware Fault</b> The current output circuit has detected an error in the output, this is most commonly due to either a broken loop or too large a load resistor.
<b>E42 :</b>	<b>Sensor Input &lt; Current OP A Zero Level</b> The sensor input level is below that set for the current output zero. Refer to current output calibration.
<b>E43 :</b>	<b>Sensor Input &gt; Current OP A Span Level</b> The sensor input level is above that set for the current output span. Refer to current output calibration.

**Floating Point Error (Consult a support engineer)**

<b>E51 :</b>	<b>Overflow Error</b>
<b>E52 :</b>	<b>Underflow Error</b>
<b>E53 :</b>	<b>Divide by 0 Error</b>
<b>E54 :</b>	<b>Too Large For Conversion</b>
<b>E55 :</b>	<b>Too Small For Conversion</b>

## INDEX

Access Entry .....	10, 14	On-Line.....	15
Bell Symbol .....	9	Padlock Symbol.....	10, 14
Cleaning .....	20	Parameters .....	16
Configuration.....	9, 12	Pipe-mounting .....	5
Connections		ppm concentration.....	16
Current Output.....	6	Pressure .....	16
Relays .....	6	Proportional Control .....	23
Sensor .....	7	Quality .....	iv
Supply Voltage .....	6	Quickstart .....	9
Current Output		Relays	
Connections .....	6	Connection.....	6
Input Source .....	22	Specification .....	1
Output Range .....	22	RFI .....	3
Zero & Span .....	22, 23	Safety .....	iv
Customer Set-up.....	37	Salinity.....	16
Default galvanic .....	35	Sensor	
Default polarographic.....	35	Connections.....	7
Dimensions		Simulation .....	16
Surface Mount Unit.....	4	Sensor Type .....	16
Display .....	9	Set Point	
Dose Alarm .....	18	1 & 2 .....	18
EMC .....	iv	Delay.....	19
EMI .....	3	Dose Alarm .....	18
Errors		Hysteresis .....	19
Messages .....	9	Level .....	18
Fault Finding .....	31	PP Mode .....	19
Fuse.....	6	Source .....	19
Installation.....	3	Trigger .....	18, 19
Interference.....	4	Specification .....	1
Key Symbol.....	10, 14	Standards .....	iv
Keys .....	9	Supply Voltage	
LCD.....	9	Connections.....	6
LEDs .....	9	Specification .....	2
LVD .....	iv	Temperature	
Menu		Ambient Variation .....	1
Structure .....	9	Operating .....	1
System .....	9	Timeout .....	11
Mounting		Units	
Pipe .....	5	Sensor .....	16
Surface.....	4	Warranty .....	iii
Noise Suppression.....	3	Wiring .....	3
Off-Line .....	9, 15	Surface Mount Unit .....	5

***Barben Analyzer Technology, LLC***

1701 S. Sutro Terrace  
Carson City, NV 89706  
United States of America

Telephone : (800)993-9309

Fax : (775)883-6388

e-mail : sales@bat4ph.com

This page intentionally blank

